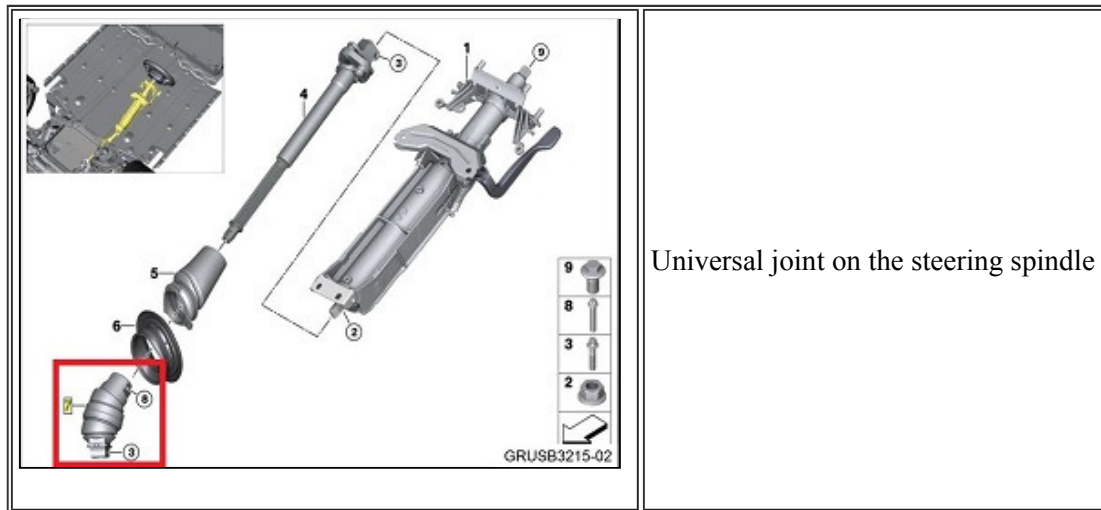

**SUBJECT****Crackling Noises from Area Around Steering Column****MODEL**

I12 (i8)

**SITUATION**

There are crackling noises from the area around the steering column when steering into bends or maneuvering the vehicle.

**CAUSE****PROCEDURE**

Replace the universal joint per Repair Manual RA 32 31 215, "Removing and installing/replacing double pivot (universal joint) for steering shaft, bottom."

**Only properly trained personnel, who have passed all applicable technical training courses, should perform any maintenance or repairs on any Hybrid or Electric Vehicle. Work performed by unqualified persons may result in severe injury or damage to the vehicle. Additional information may be found in REP 61 00... Observe safety instructions when handling electric vehicles.**

**PARTS INFORMATION**

Part Number	Description	Quantity
32 30 6 864 888	Double joint	1
32 30 6 778 609	Torx bolt M8x33	1
07 11 9 908 568	Torx bolt M8x40	1

**WARRANTY INFORMATION**

Covered under the terms of the BMW New Vehicle Limited Warranty for Passenger Cars and Light Trucks.

<b>Defect Code:</b>	<b>32 31 00 39 00</b>	

<b>Labor Operation:</b>	<b>Labor Allowance:</b>	<b>Description:</b>
32 31 211	Refer to KSD	Replacing universal joint for lower steering spindle

If you are using a Main labor code for another repair, use the Plus code labor operation 32 31 579 instead.

Refer to KSD2 for the corresponding flat rate unit (FRU) allowance.

[ Copyright ©2015 BMW of North America, Inc. ]