



SERVICE BULLETIN

SB1261A

ADDRESSEES	: Owners and users of vehicles mentioned under "Application"
VEHICLE TYPE	: T2100, C2045, CX, TX, TD925US, TDX25US, A300K, A300L, A330, AG300
CONFIGURATION GROUP	: 7.06 Steering – front-axle steering
BULLETIN TYPE	: Service Information
DATE	: June 16 th , 2015
SUBJECT	: Bevel gear of front axle steering system
TERMS & CONDITIONS	: Refer to the warranty section further in this Bulletin.

APPLICATION

The Service Information, which is subject of this bulletin, applies to the following vehicle types:

Coaches	T2140, T2145, TX40, TX45
	C2045, CX35, CX45
	TD925US, TDX25US
Busses	A300K, A300L
	A330
	AG300

DESCRIPTION

Service records have shown that the grease in the bevel gear could affect performance at very low temperatures (below -20°C/-4°F). If the grease in the bevel gear becomes hard enough to affect drivability, additional manual force could be required to turn the steering wheel. This would be especially noticeable when the steering wheel is turned the first times after an initial start-up. The phenomenon could disappear later as a matter of course due to the warming up of the grease in the bevel gear.

Additionally it has been determined that in some cases water has penetrated the bevel gear via the sealing thereby contaminating the grease. The penetrating water will start corrosion of the bearings. This problem shows a gradual, but continual increase of the steering forces and will not disappear at higher ambient temperatures or when the bevel gear is in use. Checking the bevel gear rotation torque will help in determining if the bevel gear needs to be replaced.

If either of these conditions are observed, it is necessary to replace the bevel gear by the corresponding ZF bevel gear.

Old and new bevel gears are interchangeable, but note that two different types of bevel gears are used (refer to "Versions" further on in this Bulletin for application). Also note that the new bevel gear has a mid-position which should be taken into account during the installation of the bevel gear.



Continued on next page

VERSIONS

There are two versions of the bevel gear: one with a **long** input shaft (A), one with a **short** input shaft (B). The application is different as shown in the table below.

Bevel gear version	Application
A (= long input shaft)	T2140 T2145 C2045 CX35 CX45 TX40 TX45 TD925US TDX25US A330 AG300
B (=short input shaft)	A300K A300L

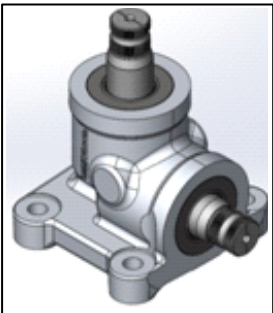
IDENTIFICATION

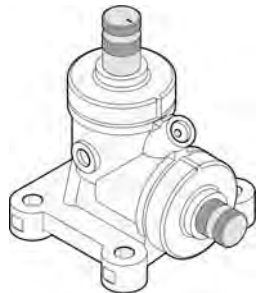
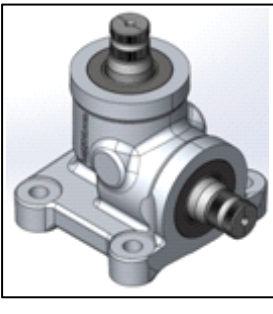
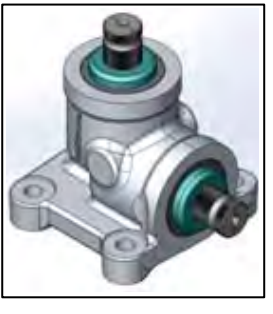
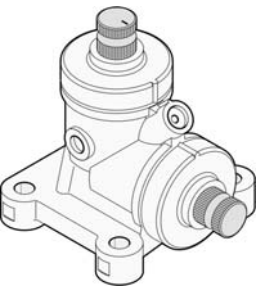
	Original Pailton bevel gear	Upgraded Pailton bevel gear (additional dust cover at input and output shafts)	New ZF bevel gear
With long input shaft			
With short input shaft			

Continued on next page

PARTS AND PRODUCTS:

Old parts

VH reference	Description
VH 11153766	Pailton bevel gear, with long input shaft (original and upgraded version have the same part number)
VH 11153765	Pailton bevel gear, with short input shaft (original and upgraded version have the same part number)

New parts

VH reference	Description
VH 10598332	ZF bevel gear, with long input shaft
VH 10598331	ZF bevel gear, with short input shaft
VH 660207406 (4x)	Self-locking nut to secure bevel gear to chassis
VH 10513551 (1x)	Self-locking nut of elastic coupling clamping bolt
VH 10513551 (1x)	Self-locking nut of universal joint clamping bolt

- Old and new parts are interchangeable, but only the new ones are supplied as spare part.
- Parts can be purchased through the usual channels (for USA/Canada: through an "ABC customer Care & Parts Source Service Center").
- Waste disposal: dispose of removed components and used products in accordance with the local environmental regulations.

TO REMOVE/INSTALL BEVEL GEAR

1. Preparations

- Park the vehicle on a level-surfaced inspection pit with the front wheels straight. Apply the parking brake, stop the engine, switch off all systems and turn off the battery master switch on the dashboard.
- Turn off the mechanical battery switch.
- Put a "DO NOT OPERATE" tag on the instrument panel before beginning any inspection or performing any repair.
- Place chocks in front of and behind the drive axle wheels.
- Read the entire procedure before beginning to work.



WARNING!

Observe safe shop practices at all times.



2. Procedure to remove the bevel gear

Step	Action
1	Make sure that the front wheels are in the straight-ahead position.
2	Remove the bolt of the steering column universal joint at the bevel gear.
3	Remove the bolt of the intermediate shaft elastic coupling at the bevel gear.
4	Remove the four bolts securing the bevel gear to the chassis and take away the bevel gear.

Continued on next page

3. Procedure to check bevel gear rotating torque

Step	Action
1	Position the bevel gear on a work bench.
2	Position a torque tester suitable for measuring small torques at the input or output shaft of the bevel gear. Check the bevel gear rotating torque by progressively increasing the force on the arm of the tester. The bevel gear must be replaced when the reading on the torque meter exceeds 0,7 Nm (0.52 ft.lbf).

4. Procedure to install the new bevel gear

Step	Action
1	Make sure that the front wheels are still in the straight-ahead position.
2	Rotate the bevel gear input shaft to align the marks on the dust cap and on the input shaft itself with the ridge on the housing. This is the “zero backlash” position of the bevel gear.
3	Slide output shaft of bevel gear (1) into elastic coupling (2) of the intermediate shaft. Make sure that the bevel gear remains in the “zero backlash” position during this step (refer to step 2).



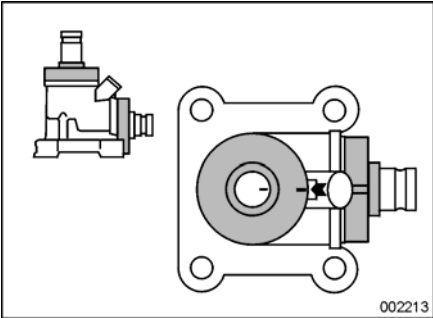

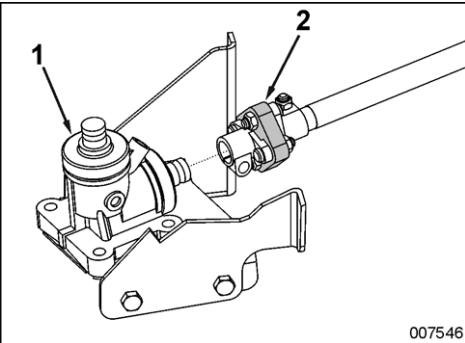
Continued on next page

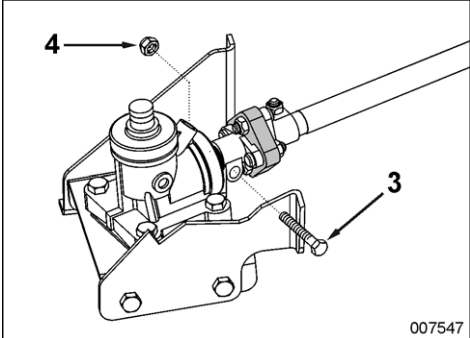
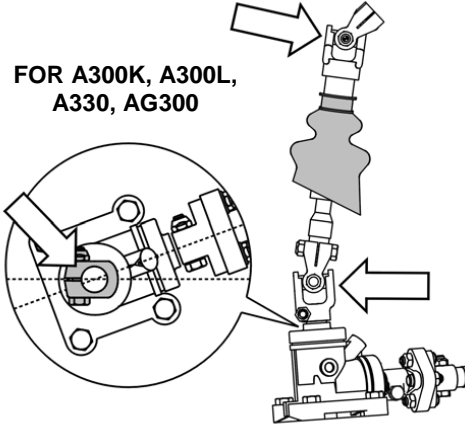
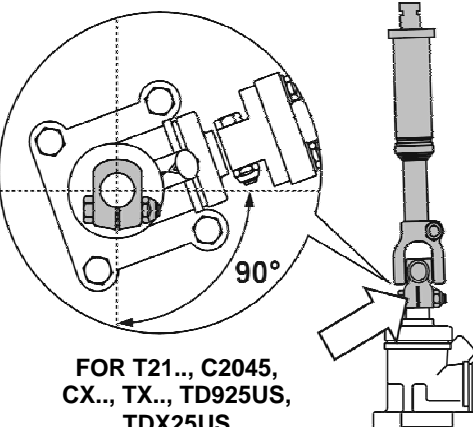
4	Secure the bevel gear to the chassis by using four M12 bolts with new self-locking nuts. If there are any shims found under the bevel gear on your vehicle, re-install them. Tighten the nuts to a torque of 70 ± 10 Nm (52 ± 7 ft.lbf).
5	<p>Install clamping bolt (3) with a new self-locking nut (4). If necessary, slacken the nut of the elastic coupling clamping bolt at the intermediate shaft side to ease installation of bolt (3).</p>  <p style="text-align: right;">007547</p>
6	Tighten the clamping bolt(s) of the elastic coupling to a torque of $48+5$ Nm ($35+3$ ft. lbf).
7	<p>Secure the universal joint of the steering column to the bevel gear with a bolt provided with a new self-locking nut.</p> <ul style="list-style-type: none"> • For busses: ensure that the clamping slot of the universal joint is parallel to the longitudinal vehicle axis (as shown in the left figure). • For coaches: ensure that the clamping slot of the universal joint is perpendicular to the longitudinal vehicle axis (as shown in the right figure). <p>Tighten the clamping bolt nut of the universal joint to a torque of $48+5$Nm ($35+3$ft.lbf).</p> <div style="display: flex; justify-content: space-around;"> <div data-bbox="375 1108 869 1579">  <p>FOR A300K, A300L, A330, AG300</p> <p style="text-align: right;">007548A</p> </div> <div data-bbox="901 1108 1412 1579">  <p>FOR T21..., C2045, CX..., TX..., TD925US, TDX25US</p> <p style="text-align: right;">005075</p> </div> </div>

Continued on next page

WARRANTY

1. Terms and conditions:

This Service Bulletin is covered by Van Hool's standard "LIMITED WARRANTY".

2. Claim submission:

Contact ABC Customer Care Warranty Department for guidance.

INFORMATION HANDLING:

Important supplements and modifications of technical information not yet included in the manual are communicated by means of Service Bulletins.

VAN HOOL CUSTOMER PORTAL:

Consult the Van Hool customer portal for the latest service documentation. Beside the maintenance manual, you will also find the operating manual and the spare parts catalogue of your vehicle on the customer portal. The customer portal is accessible through www.vanhool.be/service, and only with a code (password) from Van Hool. If you do not have a password yet, request it by using the above link.