

**DATE:** 9-4-15**APPLIES TO:** This service bulletin applies to certain incomplete chassis cabs that are to be completed as a transit buses equipped with an air spring suspension built between February 17, 2011 and April 3, 2014.**CONDITION:** Air compressor discharge line may form a water trap.**CORRECTION:** Replace and relocate air dryer**LABOR ALLOCATION:** 6 hrs.**PARTS NEEDED:**

<u>QTY</u>	<u>Part Number</u>	<u>Description</u>
1	S-2456-001	Kit-Service, Air Dryer Mounting

**Kit # S-2456-001 Contains:**

<u>QTY</u>	<u>Part Number</u>	<u>Description</u>
1	3543-MM5-001	Dryer-Air
1	3570-MM5-001	BRKT-MTG Air Dryer
4	05FWSAEZ	Wash Flat 5/16 Zinc
2	0518LNZ	Nut Lock 5/16-18 Zinc
2	05180075H5Z	Bolt 5/16-18X0.75LG Hex GR5 Zinc
3	M10125025FH7Z	Bolt M10-1.25X25MM LG FH Zinc
2	0616FLN8Y	Nut 1/2-13 FLG LK GR8 Yel.
2	06160100FH8Y	Bolt 3/8-16X1.00 FLG GR8 Yel.
2	3092-MM5-A02	Elbow 90° 4-4
1	3092-MM5-A05	Elbow 90° 6-4
2	3092-MM5-A12	Elbow 90° 10-8
12 ft.	0636-GG5-J06	Loom .38" DIA 8134 BFG
1 ft.	2517-MM-007	Nylon Tube-1/4" YEL
12 ft.	2517-MM-010	Nylon Tube-3/8" BLK
12 ft.	2517-MM5-026	Nylon Tube-5/8" BLK
12 ft.	0636-GG5-J07	Loom .63" DIA 8138 BFG
0.4 ft.	4244-RR1-001	Seal-Bulb, Headlamp Trim
1	3883-GG5-001	Harn-Air Dryer Ext.
1	3629-MM5	Plumbing Diagram
1	3571-MM5	INSTL - Air Dryer
1	TSB15-320-002	Instruction Document

Service Bulletins are intended for use by Professional Technicians only. They are written to guide Professional Technicians in performing service to vehicles of specific nature in conjunction with industry standards. Professional Technicians should be appropriately trained on industry standards and have the tools and equipment to perform procedures safely and properly.



**GENERAL INSTRUCTIONS:**

Thoroughly review entire service bulletin before starting work. If there are questions or concerns with steps defined in this service bulletin, contact Spartan Motors USA, Inc. Customer & Product Support Group.

All applicable industry safety standards must be followed when performing work identified in this procedure.

**STEP-BY-STEP INSTRUCTIONS:**

1. Properly support bus to gain access to work underneath.
2. Locate air tanks and drain all air from tanks.
3. Locate air dryer behind air tanks. Refer to FIG. 2-1.

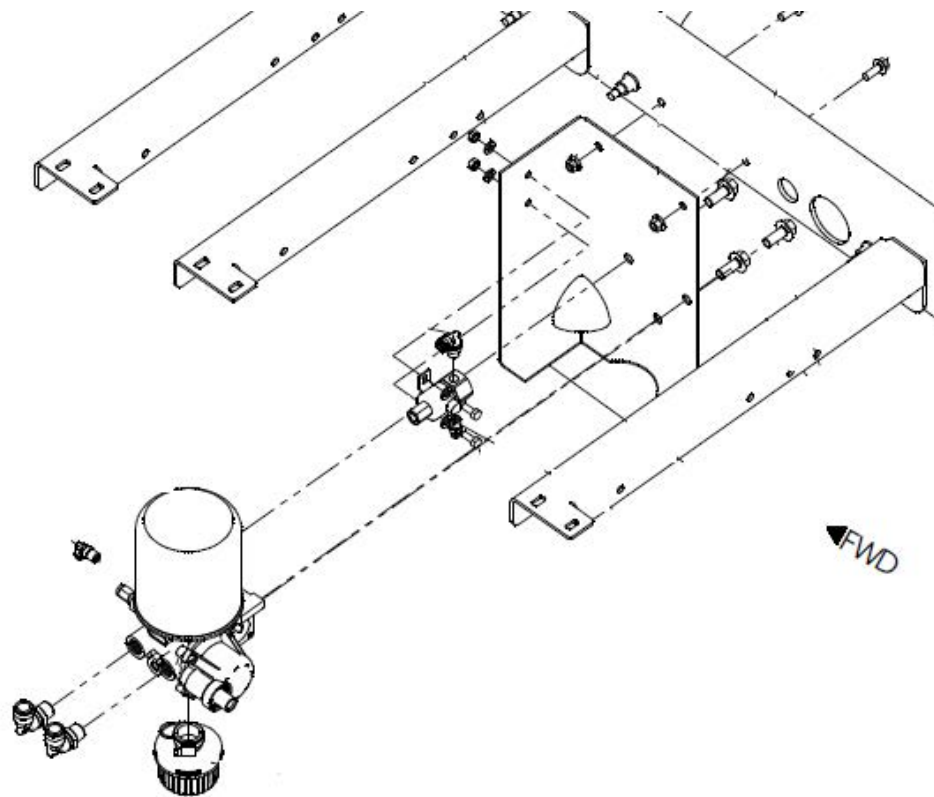

**FIG. 2-1**

Service Bulletins are intended for use by Professional Technicians only. They are written to guide Professional Technicians in performing service to vehicles of specific nature in conjunction with industry standards. Professional Technicians should be appropriately trained on industry standards and have the tools and equipment to perform procedures safely and properly.



4. Disconnect air lines from dryer.
5. Disconnect air dryer heater plug.
6. Remove air dryer and properly dispose of.
7. Remove purge solenoid and retain for re-use.
8. Remove bracket that supported air dryer and purge solenoid and properly dispose of.

**NOTE: Apply 81801 pipe sealer w/Teflon or equivalent to pipe threads only.**

9. Apply pipe sealer to both 3092-MM5-A12 (items 15), 90° elbow fittings and install in ports. Refer to FIG. 3-1. Tighten 2-3 turns from finger tight (T.F.F.T.).
10. Apply pipe sealer to 3092-MM5-A02 (item 13), 90° elbow fitting and install in port shown in FIG. 3-1. Tighten 2-3 T.F.F.T.

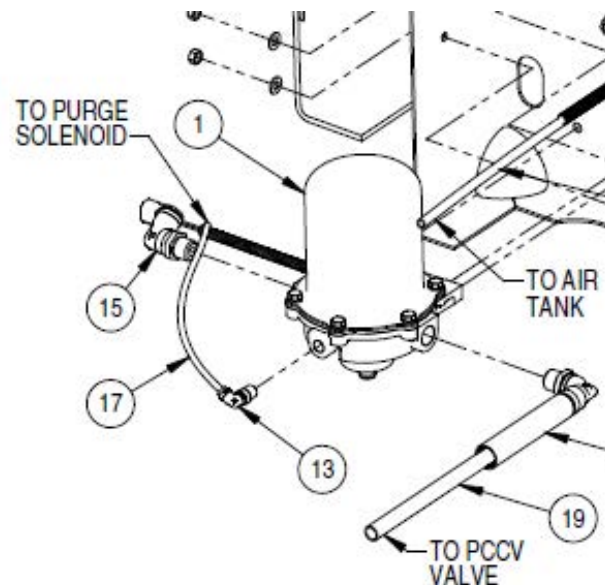

**FIG. 3-1**

11. Remove old fittings from purge solenoid and properly dispose of old fittings.

**NOTE: Apply 81801 pipe sealer w/Teflon or equivalent to pipe threads only.**

12. Install pipe sealer to 3092-MM5-A02 (item 13) and 3902-MM5-A05 (item 14) and install into retained solenoid as shown in FIG. 4-1. Tighten 2-3 T.F.F.T.

Service Bulletins are intended for use by Professional Technicians only. They are written to guide Professional Technicians in performing service to vehicles of specific nature in conjunction with industry standards. Professional Technicians should be appropriately trained on industry standards and have the tools and equipment to perform procedures safely and properly.

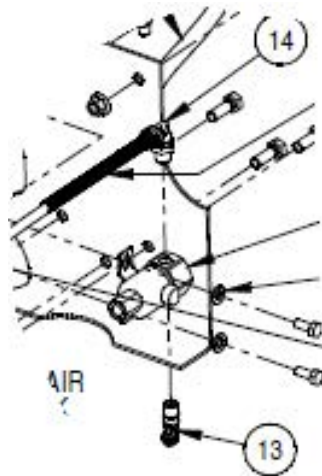

**FIG. 4-1**

- 13. Install purge solenoid on to air dryer bracket utilizing 5/16-18 hardware (items 5, 3, and 4). Torque nuts to 12 lbs.-ft. as shown in FIG. 4-2.
- 14. Install supplied air dryer onto bracket utilizing M10-1.25 hardware (item 6). Torque bolts to 14 lbs.-ft. Refer to FIG. 4-2.

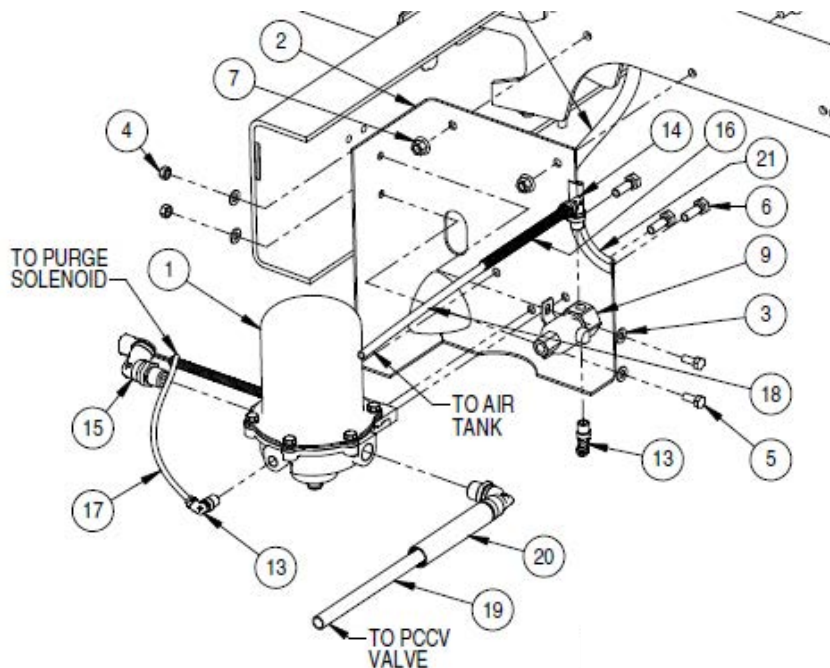
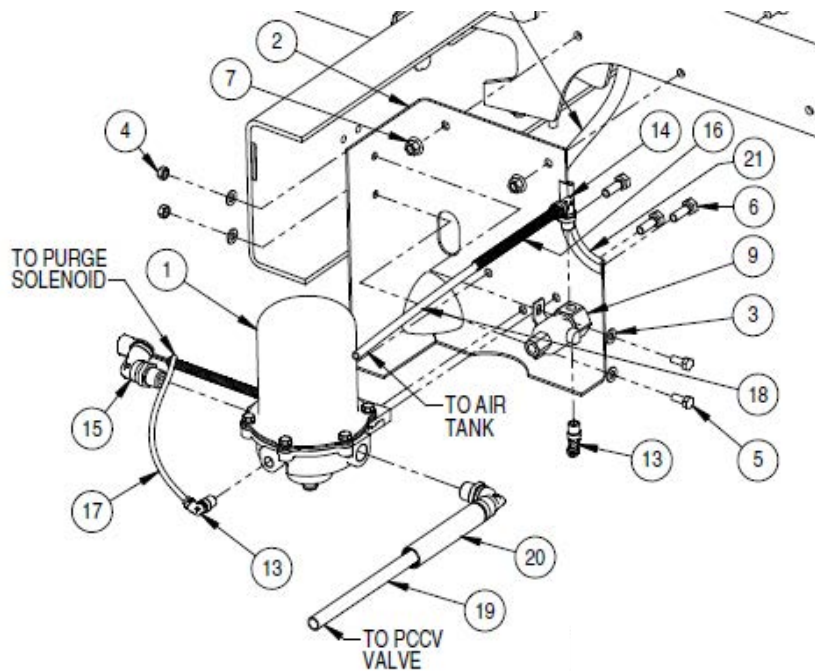

**FIG. 4-2**

Service Bulletins are intended for use by Professional Technicians only. They are written to guide Professional Technicians in performing service to vehicles of specific nature in conjunction with industry standards. Professional Technicians should be appropriately trained on industry standards and have the tools and equipment to perform procedures safely and properly.



15. Install assembled bracket to cross member utilizing 3/8-16 hardware (items 7 & 8). Torque nuts to 31 lbs.-ft. Refer to FIG. 5-1.



**FIG. 5-1**

16. Connect electrical extension harness 3883-GG5-001 to solenoid (item 9) and dryer (item 1). Connect other end of electrical harness to existing dryer connector at rear of bus by air tanks.
17. Connect airline & loom (item 19 & 20) from air dryer to air tanks at pressure control check valve (PCCV). Refer to FIG. 6-1. Connect airline (item 17) from dryer to bottom of solenoid and airline & loom (item 18 & 16) top of solenoid to air tank. Refer to FIG. 6-1. Connect other side of dryer, fitting (item 15), airline through dryer bracket to coupling & fitting (item 10 & 12). Refer to FIG. 6-1.

Service Bulletins are intended for use by Professional Technicians only. They are written to guide Professional Technicians in performing service to vehicles of specific nature in conjunction with industry standards. Professional Technicians should be appropriately trained on industry standards and have the tools and equipment to perform procedures safely and properly.

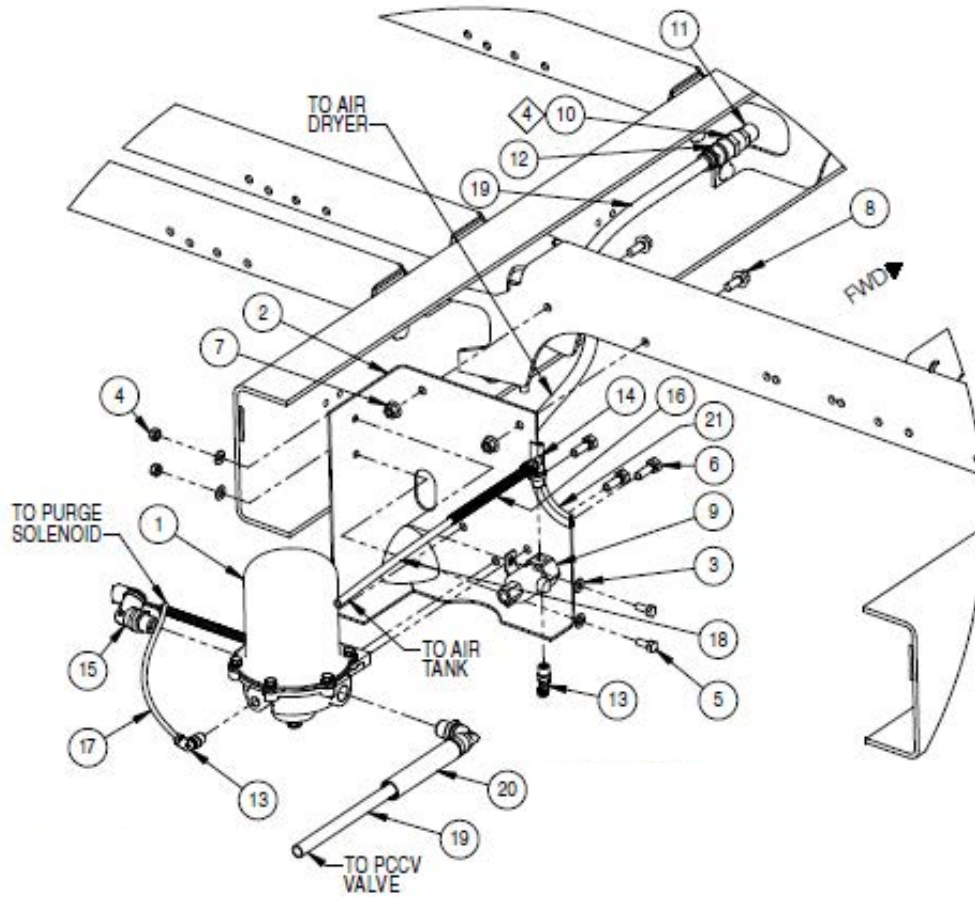

**FIG. 6-1**

18. Check installed airlines per plumbing diagram 3629-MM5. Fill air system and check for leaks, resolve any issues, tie wrap all loose airlines and cables to exiting cable runs.

Service Bulletins are intended for use by Professional Technicians only. They are written to guide Professional Technicians in performing service to vehicles of specific nature in conjunction with industry standards. Professional Technicians should be appropriately trained on industry standards and have the tools and equipment to perform procedures safely and properly.