

FLA COE
FLB COE
FLD Conventional
Business Class
FLC 112 Conventional

Century Class Conventional
Argosy COE
Cargo
Columbia

122SD and Coronado
> Business Class M2
Cascadia
> 108SD/114SD

**Freightliner
Service Bulletin**

SB-10058330-9105

This bulletin applies only to vehicles with Cummins engines.

Under certain extreme cold ambient conditions, with the vehicle parked and shut off for an extended period, as the DEF freezes, ice expansion can break the DEF line fitting connected to the suction port of a 2013 OBD / GHG14 6-gallon DEF header. See [Fig. 1](#). For vehicles that are typically exposed to these kinds of conditions and have had the occurrence, a different suction stand pipe and DEF line design can be retrofitted using kit part number Z04-32079-000.

Replacing the suction stand pipe involves removing the header from the tank, disassembling the header and reassembling it with the new suction stand pipe that has smaller diameter and a larger fitting. With the larger fitting on the stand pipe, a different DEF line is required to connect to it.



Fig. 1, Ice Expansion at the DEF Line Fitting

Replacement

Refer to [Fig. 2](#) for this procedure.

1. Park the vehicle on a level surface, shut down the engine, and set the parking brakes. Chock the tires.
2. Disconnect the batteries.
3. Using line clamp pliers, clamp the DEF tank coolant hoses.
4. Place a collection container under the DEF tank.
5. Disconnect the coolant hoses and plug them.
6. Disconnect the DEF lines.
7. Disconnect the harness connectors from the DEF level sensor.
8. If necessary, remove the DEF tank from the vehicle.
 - 8.1 Cut the zip ties holding chassis electrical harness to blue DEF lines on side of tank.
 - 8.2 Disconnect the DEF lines from the DEF tank header.
 - 8.3 Disconnect coolant supply lines from the DEF tank header.
 - 8.4 Remove two DEF tank mounting bolts, then remove DEF tank from truck.

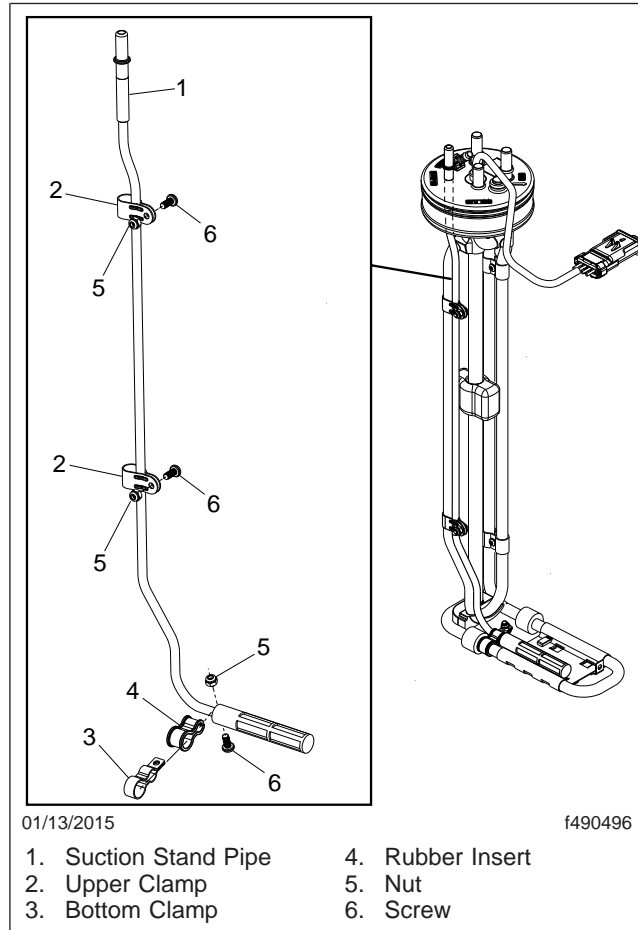

Fig. 2, WEMA Six Gallon DEF Tank Header Assembly

NOTICE

The foot of the header is oriented away from the filler port. It must be "maneuvered" out of the tank. Applying excessive force on the header during removal or installation may damage it.

9. Remove the header from the DEF tank.
10. If desired, rinse the header unit with hot water before working on it.
11. Replace the DEF suction stand pipe.
 - 11.1 Remove the clamps that attach the suction stand pipe to the coolant pipe. (These may be clamps with screws and nuts, springs wound around the pipes, or zip ties.)
 - 11.2 Remove the rubber insert from the bottom clamp if applicable.

NOTE: It takes about 9 kg of pulling force to remove the suction stand pipe from the rubber head.

- 11.3 Slide the suction stand pipe out from the bottom of the rubber head.

2013 OBD/GHG14, 6-Gallon DEF Header Suction Line Connection Broken by Ice Pressure

49-37

FLA COE
FLB COE
FLD Conventional
Business Class
FLC 112 Conventional

Century Class Conventional
Argosy COE
Cargo
Columbia

122SD and Coronado
> Business Class M2
Cascadia
> 108SD/114SD

**Freightliner
Service Bulletin**

- 11.4 Install the new suction stand pipe into the rubber head from the bottom. Make sure it is properly positioned.
- 11.5 Install the new bottom clamp with the rubber insert directly behind the filter.
- 11.6 Install the new clamps at the two upper locations as shown in [Fig. 2](#).
- 11.7 Tighten the clamp fasteners 25 to 29 lbf-in (280 to 360 N-cm).
- 11.8 Verify that the stand pipe sticks out of the top of the head enough to connect the DEF line fitting.
- 11.9 Verify that the DEF level float can travel freely for the entire length of the sensor tube.

NOTICE

The foot of the header is oriented away from the filler port. It must be "maneuvered" into of the tank. Applying excessive force on the header during removal or installation may damage it.

12. Install the header unit in the tank and secure it with the band clamp.
13. If the DEF tank was removed, position the tank on the frame rail bracket, and install the two DEF tank mounting bolts and nuts. Tighten 128 lbf-ft (174 N-m).
14. Remove the DEF suction line and install the new one.
15. Connect the DEF lines.
16. Connect the coolant lines.
17. Install zip ties as needed to hold the chassis electrical harness to blue DEF lines on side of tank.
18. Remove the line clamps.
19. Connect the harness connector to the DEF sensor.
20. Connect the battery cables.
21. Start the engine and check for leaks. Repair as needed.
22. Put a dot of white paint on the connector to indicate the retrofit has been done.

Parts

This kit is only for Cummins equipped vehicles.

Parts are available through the PDC. Order kit number Z04-32079-000 for the required parts.

Warranty

This procedure is warrantable only if the described condition exists and the repair is performed within the applicable base or extended coverage warranty period. If a failure is not found, this procedure is considered preventive and warranty does not apply.

Normal warranty applies. See [Table 1](#) for OWL VMRS codes and labor allowance information. Enter this service bulletin number in the *Service Bulletin #* field.

49-37

2013 OBD/GHG14, 6-Gallon DEF Header Suction Line Connection Broken by Ice Pressure

Freightliner Service Bulletin

FLA COE
FLB COE
FLD Conventional
Business Class
FLC 112 Conventional

Century Class Conventional
Argosy COE
Cargo
Columbia

122SD and Coronado
> Business Class M2
Cascadia
> 108SD/114SD

OWL VMRS Codes and Labor Allowance					
Primary Failed Part	Component Code	Cause Code	SRT Code	Description	Time: Hours
04-30404-000	043-007-084	12	23U-5010	DEF TANK PICKUP TUBE, R/R	1.0

Table 1, OWL VMRS Codes and Labor Allowance