

SB-10058302-1009

Subject: Cascadia CNG Exhaust Mitigation

Models Affected: Specific Freightliner Cascadia vehicles manufactured March 27, 2012, through November 4, 2014, and equipped with CNG fuel tanks.

General Information

IMPORTANT: Due to the small number of vehicles in this campaign, the vehicle serial number is required when ordering the kit and parts listed in **Table 1**. Advance arrangements with the customer are required for this campaign. When a customer contacts the dealership regarding SF504A-C, place a stock order for the appropriate kit and part numbers, and include the vehicle serial number in the notes of your order. Schedule the vehicle to arrive after the kits have been received at the dealership.

NOTE: Kit 25-FL671-000 will be used for this repair.

Daimler Trucks North America LLC, on behalf of its Freightliner Trucks Division, is initiating Field Service Campaign SF504A-C to modify the vehicles mentioned above.

Certain compressed natural gas (CNG) powered vehicles were built with the exhaust tailpipe terminating near the CNG tank protection relief valve. Over time continual heating of the CNG tank protection relief valve by the exhaust discharge may result in the CNG venting.

A tailpipe extension will be installed to move the exhaust termination beyond the end of the CNG tank protection relief valve.

There are approximately 17 vehicles involved.

Additional Repairs

Dealers must complete all outstanding field service campaigns prior to the sale or delivery of a vehicle. A Dealer will be liable for any progressive damage that results from its failure to complete campaigns before sale or delivery of a vehicle.

Owners may be liable for any progressive damage that results from failure to complete campaigns within a reasonable time after receiving notification.

Please contact Warranty Campaigns for consideration of additional charges prior to performing the repair.

Work Instructions

Please refer to the attached work instructions. Prior to performing the campaign, check the vehicle for a completion sticker (Form WAR261).

Replacement Parts

Replacement parts are now available and can be obtained by ordering the kit and part number(s) listed in Table 1. from your facing Parts Distribution Center.

If our records show your dealership has ordered any vehicle(s) involved in campaign SF504A-C, a list of the customers and vehicle identification numbers will be available on AccessFreightliner.com. Please refer to this list when ordering parts for this campaign.

Field Service Campaign

Daimler Trucks
North America LLC

March 2015
SF504A-C

Table 1 - Replacement Parts for SF504A-C

IMPORTANT: Due to the small number of vehicles in this campaign, the vehicle serial number is required when ordering the kit and parts listed in **Table 1**. Advance arrangements with the customer are required for this campaign. When a customer contacts the dealership regarding SF504A-C, place a stock order for the appropriate kit and part numbers, and include the vehicle serial number in the notes of your order. Schedule the vehicle to arrive after the kits have been received at the dealership.

NOTE: Kit 25-FL671-000 will be used for this repair.

Campaign Number	Part Description	Part Number	Qty.
SF504A (4 vehicles)	Hardware Kit (see Table 2 for kit contents)	25-FL671-000	1 ea
	PIPE CTLST OUT-NAT GAS-20 IN	04-31956-020	1 ea
	BRKT-EXH,HORZ TLPP SUPT,P3 NG	04-28222-000	1 ea
	Blank Grey Completion Sticker	WAR261	1 ea
SF504B (2 vehicles)	Hardware Kit (see Table 2 for kit contents)	25-FL671-000	1 ea
	PIPE CTLST OUT-NAT GAS-15 IN	04-31956-015	1 ea
	BRKT-EXH,HORZ TLPP SUPT,P3 NG	04-28222-000	1 ea
	Blank Grey Completion Sticker	WAR261	1 ea
SF504C (11 vehicles)	PIPE CTLST OUT-NAT GAS-10 IN	04-31956-010	1 ea
	CLAMP-BND,5IN,PLN,ACCUSEAL	ABP N35 100725	2 ea
	Blank Grey Completion Sticker	WAR261	1 ea

Table 1

NOTE: Do NOT order from Table 2. The kit contents listed below are for information only. When ordering the Hardware Kit, please order kit number 25-FL671-000 and the quantity specified above in **Table 1**.

25-FL671-000 Hardware Kit Contents

Part Description	Part Number	Qty. per Kit
CLAMP-SDL,5"PLN,3/8-16 NUTS	CI U500F1	1 ea
WASHER-HRDN,0.69X1.31X.177,ZN	23-09114-000	4 ea
SCREW-CAP,HEX5/8-11X2.25 GR8PO	23-09444-225	2 ea
NUT-HEX,PT,5/8-11,C,ZN/AL	23-13833-110	2 ea
O-RING NITRILE	PH 2014N1490	1 ea
CLAMP-BND,5IN,PLN,ACCUSEAL	ABP N35 100725	2 ea
Blank Red Completion Sticker	WAR260	1 ea

Table 2

Removed Parts

U. S. and Canadian Dealers, please follow Warranty Failed Parts Tracking shipping instructions for the disposition of all removed parts. Export distributors, please destroy removed parts unless otherwise advised.

Labor Allowance

Table 3 - Labor Allowance

Campaign Number	Procedure	Time Allowed (hours)	SRT Code	Corrective Action
SF504AB	Install extension pipe and one bracket	2.7	996-0945B	12-Repair Recall/Campaign
SF504C	Install extension pipe with no brackets	0.5	996-0945A	

Table 3

IMPORTANT: When the campaign has been completed, locate the base completion label in the appropriate location on the vehicle, and attach the gray completion sticker provided in the field service kit (Form WAR261). If the vehicle does not have a base completion label, clean a spot on the appropriate location of the vehicle and first attach the base completion label (Form WAR259). If a field service kit is not required or there is no completion sticker in the kit, write the campaign number on a blank sticker and attach it to the base completion label.

Claims for Credit

You will be reimbursed for your parts, labor, and handling (landed cost for Export Distributors) by submitting your claim through the Warranty system within 30 days of completing this campaign. Please reference the following information in OWL:

- Claim type is **Field Service Campaign**.
- In the Campaign field, enter the campaign number and appropriate group (e.g. **SF504-A, SF504-B, etc.**).
- In the Primary Failed Part field, enter **25-SF504-000**.
- In the Parts section, enter the appropriate kit and part number(s) as shown in **Table 1**.

NOTE: Kit 25-FL671-000 will be used for this repair.

- In the Labor section, enter the appropriate SRT from the Labor Allowance Table. Administrative time will be included automatically as SRT 939-6010A for 0.3.
- The VMRS Component Code is **043-003-012** and the Cause Code is **A1 - Campaign**.

This Field Service Campaign will **terminate on March 31, 2016**. Dealers will be notified of any changes to the termination date via Important Campaign Information Letter posted on AccessFreightliner.com.

IMPORTANT: OWL must be viewed prior to beginning work to ensure the vehicle is involved and the campaign has not previously been completed. Also, check for a completion sticker before beginning work.

All claims must be submitted within 30 days of the repair and within 30 days of the termination date of the campaign. U.S. and Canadian Dealers: All excess inventory to be returned to the PDC following the conclusion of the campaign must be returned in resaleable condition to the Memphis PDC within 90 days from the termination date. Please submit a PAR to request return to the Memphis PDC. (Canadian dealers should return the kits to their facing PDC.) Export Distributors: Excess inventory is not returnable.

For questions, U.S. and Canadian dealers, contact the Warranty Campaigns Department from 7:00 a.m. to 4:00 p.m. Pacific Time, Monday through Friday, via Web inquiry at AccessFreightliner.com / Support / My Tickets and Submit an Inquiry, or the Customer Assistance Center at (800) 385-4357, after normal business hours, if you have any questions or need additional information. Export distributors submit a Web inquiry or contact your International Service Manager.

March 2015
SF504A-C

Copy of Notice to Owners

Subject: Cascadia CNG Exhaust Mitigation

Daimler Trucks North America LLC, on behalf of its Freightliner Trucks Division, is initiating Field Service Campaign SF504A-C to modify specific Freightliner Cascadia vehicles manufactured March 27, 2012 through November 4, 2014, and equipped with CNG fuel tanks.

Certain compressed natural gas (CNG) powered vehicles were built with the exhaust tailpipe terminating near the CNG tank protection relief valve. Over time continual heating of the CNG tank protection relief valve by the exhaust discharge may result in the CNG venting.

A tailpipe extension will be installed to move the exhaust termination beyond the end of the CNG tank protection relief valve.

Please contact an authorized Daimler Trucks North America dealer to arrange to have the campaign performed and to ensure that parts are available at the dealership. To locate an authorized dealer, search online at www.Daimler-TrucksNorthAmerica.com / Contact Us / Find a Dealer. **Advance arrangements are required to ensure parts will be available at the dealership.** The campaign will take approximately one to three hours, depending on the repair, and will be performed at no charge to you.

This Field Service Campaign will **terminate on March 31, 2016**. Please make sure the campaign is completed prior to this date. Work completed after this date will be done at the customer's expense.

As stated in the terms of your express limited warranty, Daimler Trucks North America LLC will not pay for any damage caused by failure to properly maintain your vehicle. Daimler Trucks North America LLC considers the work necessary under this campaign to be proper maintenance and will, therefore, not pay for any damage to your vehicle caused by your failure to have the repairs that are the subject of this campaign performed in a reasonable time.

Contact the Warranty Campaigns Department at (800) 547-0712, from 7:00 a.m. to 4:00 p.m. Pacific Time, Monday through Friday, e-mail address DTNA.Warranty.Campaigns@Daimler.com, or the Customer Assistance Center at (800) 385-4357, after normal business hours, if you have any questions or need additional information.

WARRANTY CAMPAIGNS DEPARTMENT

Enclosure

Work Instructions

Subject: Cascadia CNG Exhaust Mitigation

Models Affected: Specific Freightliner Cascadia vehicles manufactured March 27, 2012, through November 4, 2014, and equipped with CNG fuel tanks.

IMPORTANT: Due to the small number of vehicles in this campaign, the vehicle serial number is required when ordering the kit and parts listed in **Table 1**. Advance arrangements with the customer are required for this campaign. When a customer contacts the dealership regarding SF504A-C, place a stock order for the appropriate kit and part numbers, and include the vehicle serial number in the notes of your order. Schedule the vehicle to arrive after the kits have been received at the dealership.

NOTE: Kit 25-FL671-000 will be used for this repair.

The installation will vary depending on the vehicle configuration. Determine the correct installation before starting this procedure.

Vehicles in SF504AB require one hanger bracket. Refer to **Fig. 1**. Vehicles in SF504C do not require a hanger bracket. Refer to **Fig. 2**.

Exhaust Pipe Installation

1. Check the base label (Form WAR259) for a completion sticker for SF504 (Form WAR261) indicating this work has been done. The base label is usually located on the passenger-side door about 12 inches (30 cm) below the door latch. If a sticker is present, no work is needed. If there is no sticker, proceed to the next step.
2. Park the vehicle on a level surface, shut down the engine, and set the parking brake. Chock the tires.

WARNING

Read and understand the Safety Precautions in Subject 47.04, 100 of the *Cascadia Workshop Manual* before working on the Compressed Natural Gas (CNG) system. Failure to follow the prescribed safety precautions could lead to fire, explosion, property damage, and/or personal injury.

3. Remove the existing exhaust pipe and mitigator. Save the mitigator for reinstallation. Discard the clamps and pipe.
4. If vehicle requires a hanger bracket (SF504AB), go to "Installation Using the Hanger Bracket" on this page.
If vehicle does not require a hanger bracket (SF504C), go to "Installation Using No Hanger Bracket" on page 7.

Installation Using the Hanger Bracket

NOTICE

In some cases, when adding the hanger bracket, the right side frame-rail-mounted CNG tank may need to be removed to gain access. For instructions, refer to Section 47.04 of the *Cascadia Workshop Manual*. Failure to follow the prescribed safety precautions could lead to fire, explosion, property damage, and/or personal injury.

1. If needed, remove the right side frame-rail-mounted CNG tank.

Field Service Campaign

Daimler Trucks
North America LLC

March 2015
SF504A-C

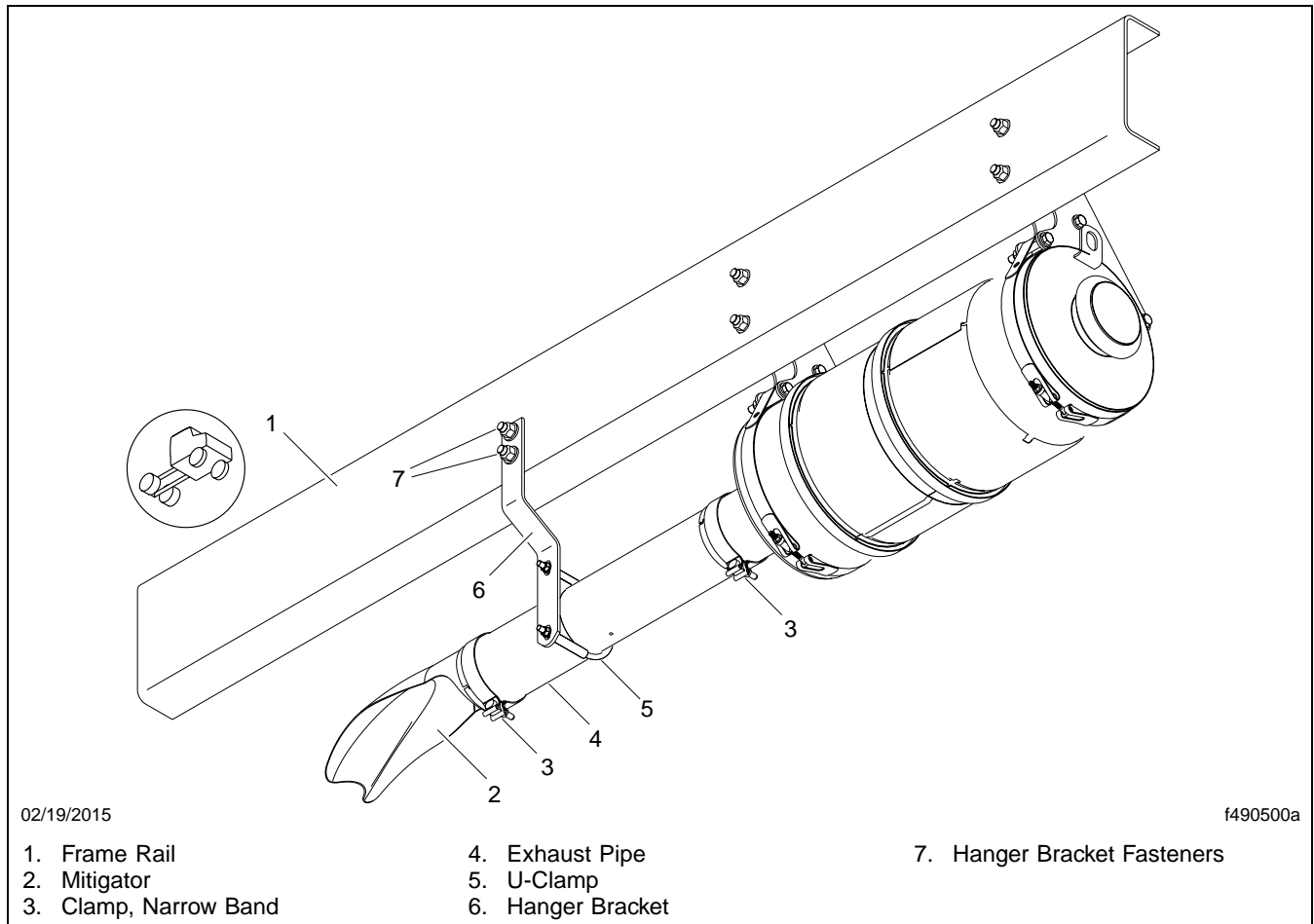

Fig. 1, Exhaust Pipe Installation, Direct to the Frame Rail Mounting

IMPORTANT: The preferred location for the new hanger bracket is in existing holes in the frame rail, if available. Choose the hole locations with the best access from both sides of the frame rail. Do not attach the hanger bracket to the back-of-cab CNG tank cabinet mounting bracket, doing so will mis-align the exhaust. If drilling holes in the frame rail is required, follow the "Drilling Holes" guidelines in **Subject 31.00, 100** of the *Cascadia Workshop Manual*.

- Determine the best location for the hanger bracket.
- Install the mitigator on the new pipe using the new band clamps. Tighten the clamps 35 to 47 lbf·ft (47 to 64 N·m).
- Position the pipe and mitigator assembly on the muffler with the mitigator outlet facing the ground, support the rear of the pipe as needed.

NOTE: It is acceptable to locate the hanger bracket outside of the ideal location to access a clear spot on the frame rail.

- Using the U-clamp from the kit, position the hanger bracket from the kit on the extension pipe 6 to 12 inches (150 to 300mm) forward of the mitigator clamp. Only tighten the clamp enough to position the bracket at this time.
- Clamp the bracket in place on the frame rail, then back-drill the frame rail as needed. See **Fig. 1**.
- Attach the hanger bracket to the frame rail using the nuts, bolts, and washers from the hardware kit. Tighten the mounting nuts and bolts 128 lbf·ft (173 N·m).

8. Tighten the clamp at the muffler 35 to 47 lbf·ft (47 to 64 N·m).
9. Tighten the U-clamp nuts 20 to 26 lbf·ft (27 to 35 N·m).
10. If removed, install the right side frame-rail-mounted CNG tank. For instructions, refer to **Section 47.04** of the *Cascadia Workshop Manual*.

Replace the o-ring (p/n PH 2014N1490) when installing the high pressure fuel connection.

11. Clean a spot on the base label (Form WAR259). Write the campaign number, SF504, on a blank grey completion sticker (Form WAR261) to indicate the work has been completed and attach it to the base label.

Installation Using No Hanger Bracket

1. Install the mitigator on the new pipe using the new band clamps. Tighten the clamps 35 to 47 lbf·ft (47 to 64 N·m).
2. Position the pipe and mitigator assembly on the muffler with the mitigator outlet facing the ground, support the rear of the pipe as needed.
3. Tighten the clamp at the muffler 35 to 47 lbf·ft (47 to 64 N·m).

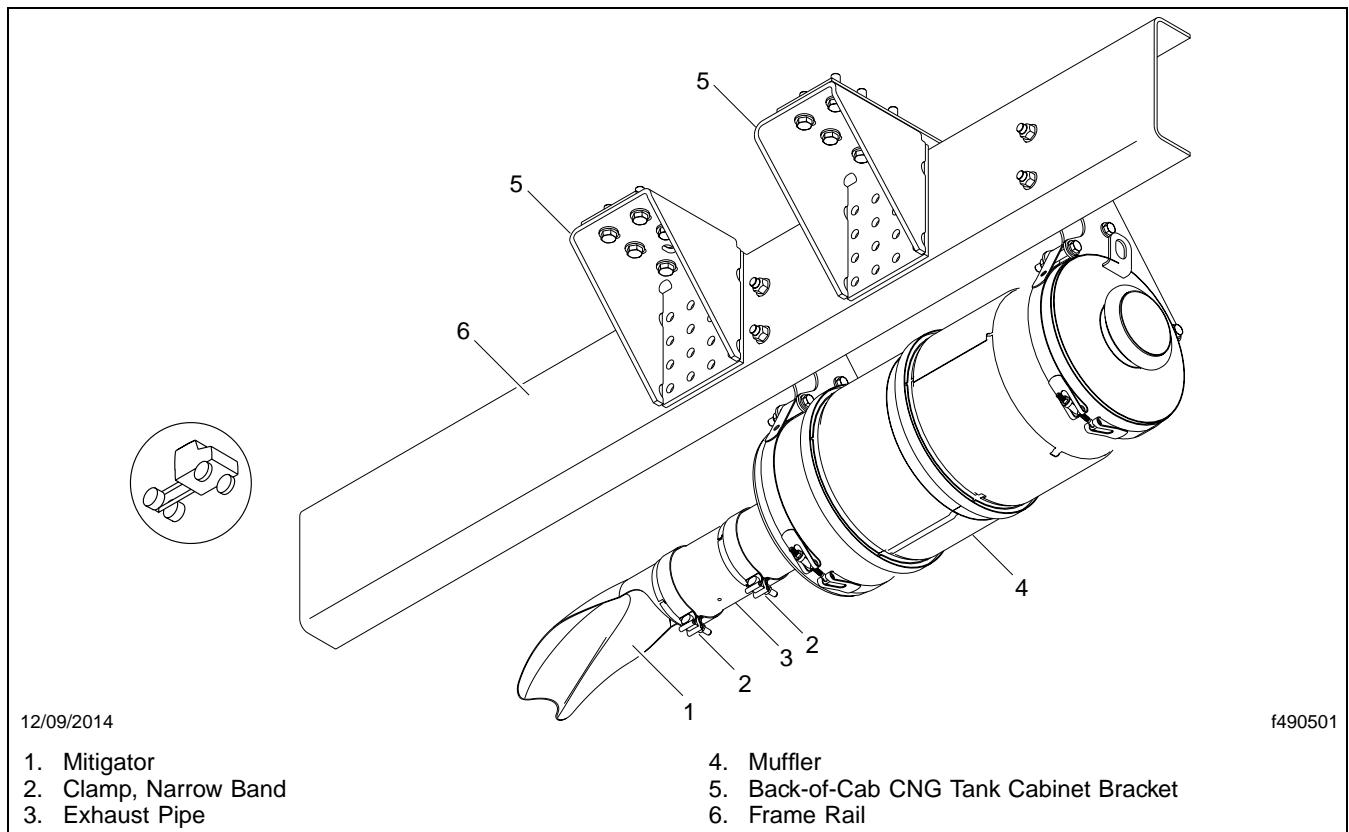

Fig. 2, Exhaust Pipe Installation, No Hanger

4. If removed, install the right side frame-rail-mounted CNG tank. For instructions, refer to **Section 47.04** of the *Cascadia Workshop Manual*.

Replace the o-ring (p/n PH 2014N1490) when installing the high pressure fuel connection.

5. Clean a spot on the base label (Form WAR259). Write the campaign number, SF504, on a blank grey completion sticker (Form WAR261) to indicate the work has been completed and attach it to the base label.