

SERVICE BULLETIN

SB-10058276-4396

Reference number:	SB-07-0401	Issued: 10 July 2015
Subject:	Failure of the Clutch Fluid Supply Line on 6-Speed ASM Transmission	
Model(s):	V8 Vantage only	
VIN Range:	From C15849 to D16311	
Applicable to:	All Dealers	
Distribute to:	After Sales Manager Executive Manager Service Manager Sales Manager	Warranty Technician(s) Parts

Reason for this Service Bulletin

From VIN C15849, the 6-speed ASM transmission that is installed on V8 Vantage, has a different connector design that connects the clutch fluid supply tube to the transmission. It is possible that this connector can fail and cause loss of the clutch fluid and incorrect operation of the transmission. If a 6-speed ASM vehicle comes into your Dealer that:

- Is in the range of affected VINs
- Has lost or leaking clutch fluid from the transmission
- Has incorrect operation of the clutch,

Examine the connector between the clutch fluid tube and the transmission. If there is a fluid leak, do the Workshop Procedure that follows to replace the connector assembly and related pipes. In this procedure, you will replace connector type A shown in Figure 1 with connector type B.

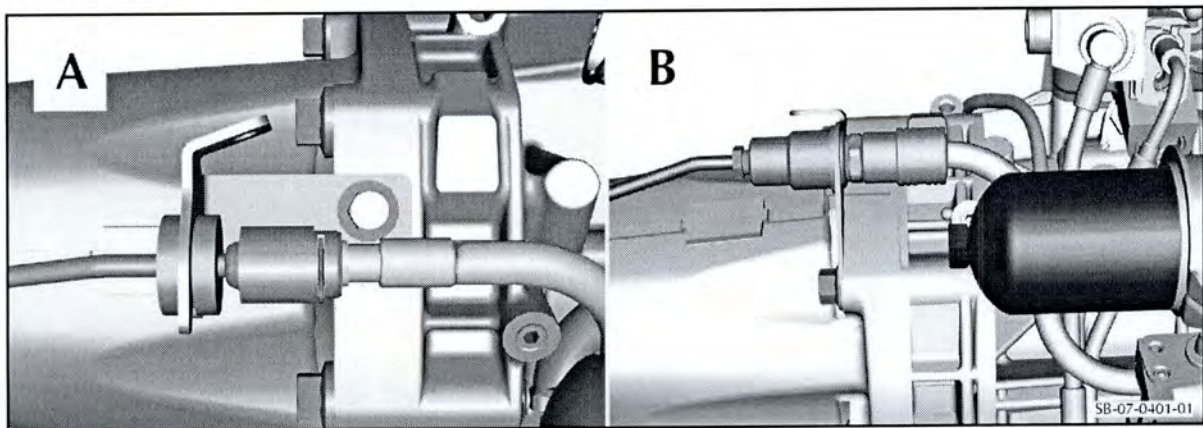

Figure 1

Workshop Procedure

This Workshop Procedure has the parts that follow:

Part A - Remove the transaxle assembly

Part B – Remove the torque tube assembly

Part C – Change the supply tube assembly for the concentric slave cylinder

Part D – Change the hose for the dry break connector

Part E – Install the torque tube assembly

Part F – Install the transaxle assembly

Part A - Remove the transaxle assembly

WARNING: THE EXHAUST SYSTEM WILL BE VERY HOT AFTER OPERATION AND CAN BURN YOU. LET THE EXHAUST SYSTEM COOL BEFORE YOU DO WORK ON THE SYSTEM.

1. Make sure that the transmission is in neutral gear.
2. Put the vehicle in position on a lift.
3. Use an applicable strap to attach the vehicle to the lift.
4. Do the battery disconnect procedure (refer to Workshop Manual procedure 14.01.CA).
5. Lift the vehicle and make it safe.
6. Drain the fluid from the transaxle (refer to Workshop Manual procedure 07.03.BC).
7. Hold the cross brace (2). Remove the four screws (1) that attach the cross brace (2) and remove the cross brace (2) (refer to Figure 2).

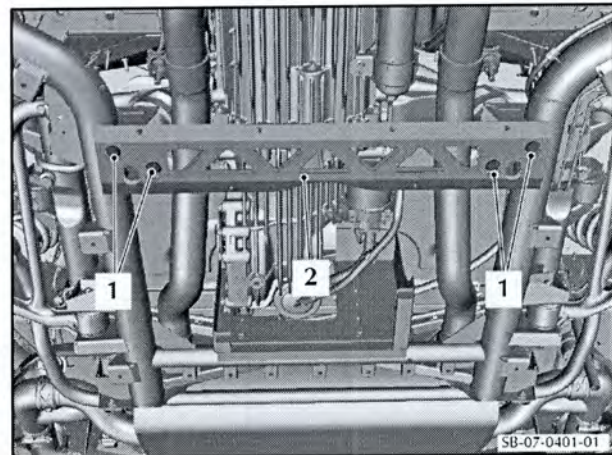

Figure 2

8. Remove the four bolts and collect the four springs that attach the exhaust centre pipe to the muffler and bypass valve assembly (refer to Figure 3).

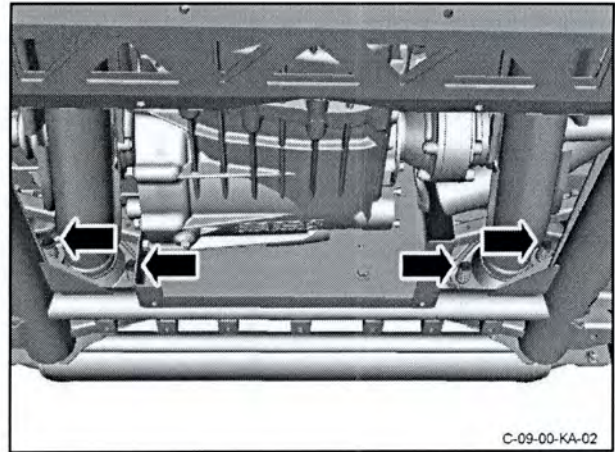

Figure 3

9. Loosen the two bolts on the clamps that attach the catalytic converter and pipe assemblies to the centre exhaust pipe (refer to Figure 4).

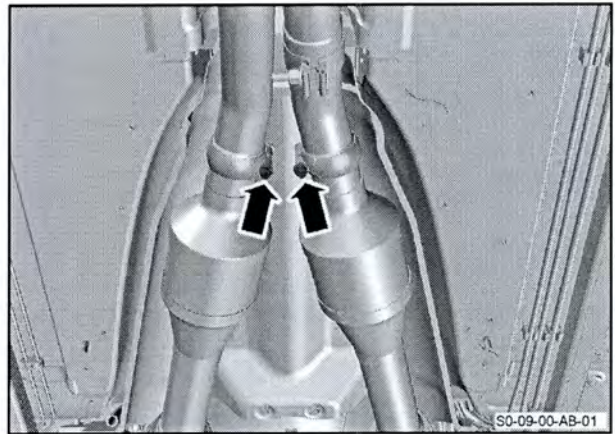

Figure 4

10. Move the two clamps on the catalytic converter and pipe assemblies away from the centre exhaust pipe (refer to Figure 5).

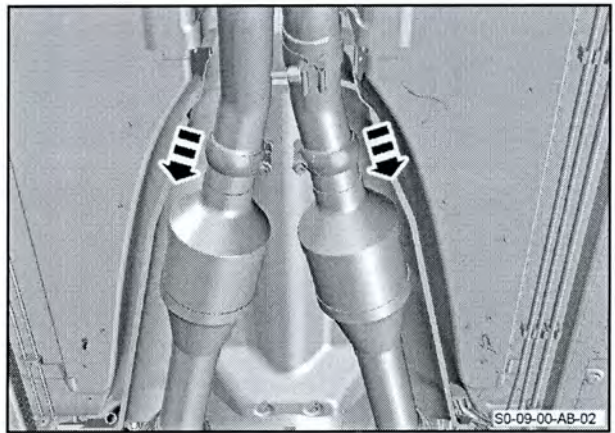

Figure 5

11. Put an applicable support below the centre exhaust pipe.

WARNING: THE EXHAUST PIPES ARE HEAVY. GET THE AID OF ONE MORE PERSON WHEN YOU DO THE STEPS THAT FOLLOW.

12. Remove the four attachment bolts for the centre exhaust mounting (refer to Figure 6).

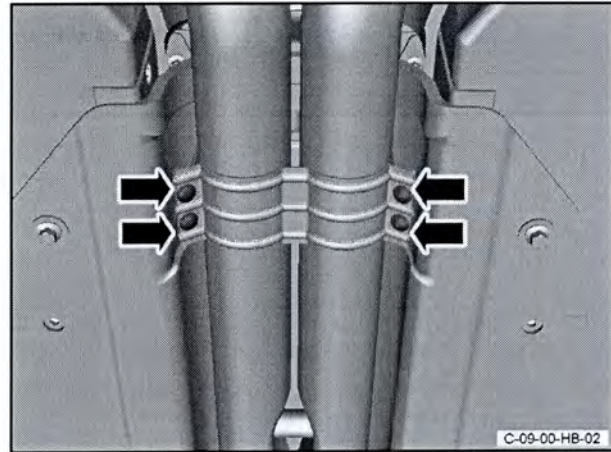

Figure 6

13. Loosen the two clamp nuts and release the centre pipe from the two catalyts.
14. Remove the centre pipe and the rear exhaust pipes as an assembly (refer to Figure 7).

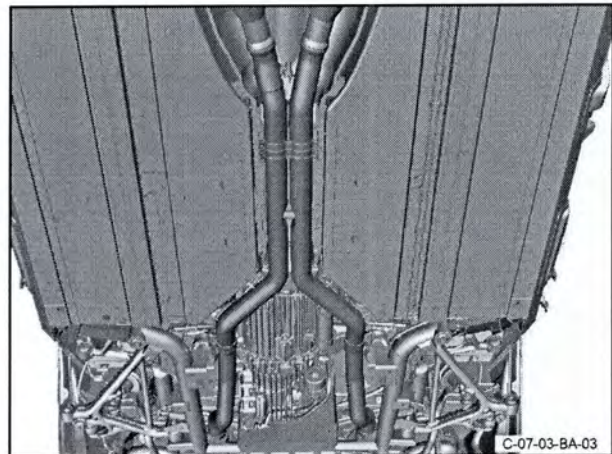

Figure 7

15. Remove and discard the two sealing rings (refer to Figure 8).

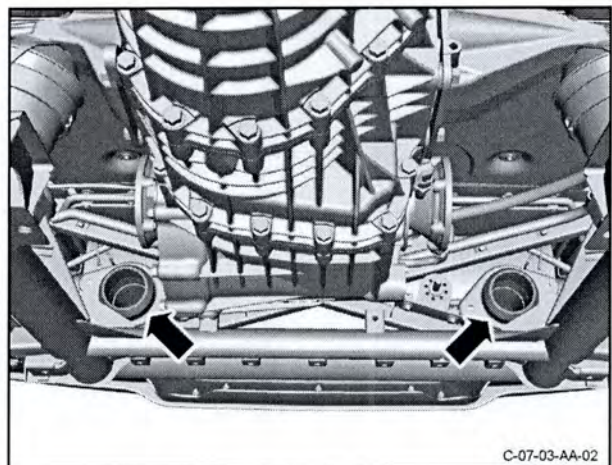

Figure 8

16. Remove the exhaust centre brace assembly (refer to Figure 9).

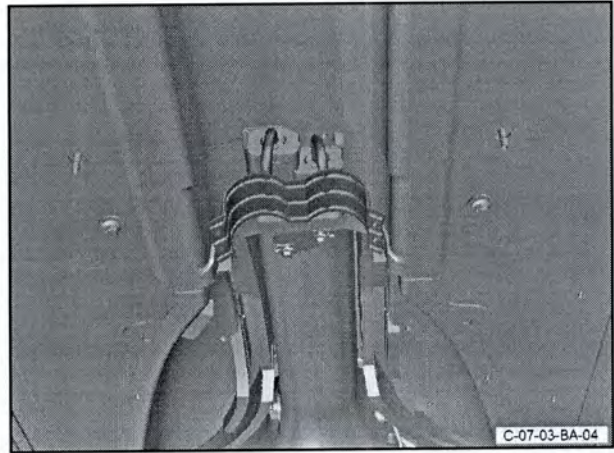

Figure 9

17. Remove the four bolts and four washers (1) that attach the tunnel heatshield (2) to the body. Remove the heatshield (2) (refer to Figure 10).

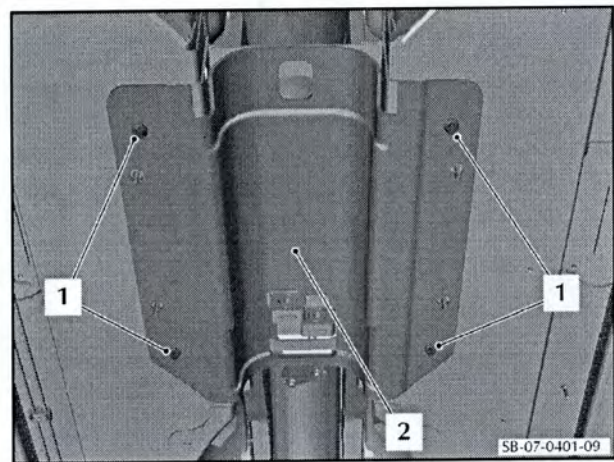

Figure 10

18. Remove the eight bolts (1) that attach the tunnel reinforcement plate (2) to the body and remove the plate (2) (refer to Figure 11).

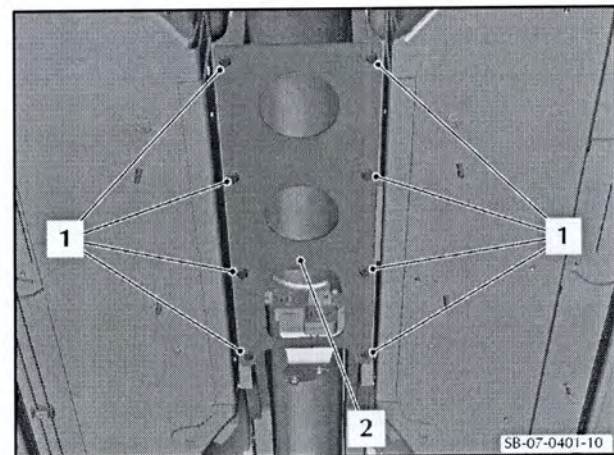

Figure 11

19. Remove the bolt (1) that attaches the ground cable (2) to the transmission mount bracket (3) and move the ground cable (2) away (refer to Figure 12).

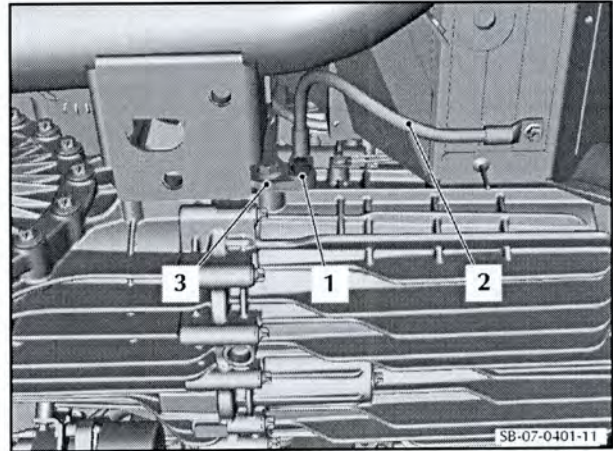

Figure 12

20. Make a mark on each of the two drive shaft to differential flanges for alignment during assembly.
21. Remove and discard the six Allen head bolts that attach the left drive shaft flange to the transaxle. Collect the three locking plates from the drive shaft flange (refer to Figure 13).

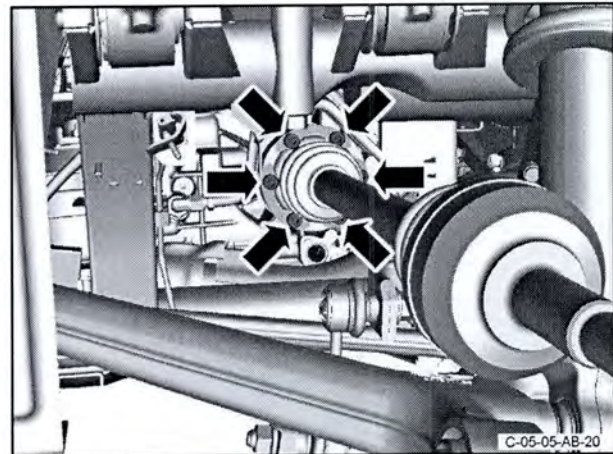

Figure 13

22. Remove and discard the six Allen head bolts that attach the right drive shaft flange to the transaxle. Collect the three locking plates from the drive shaft flange (refer to Figure 14).

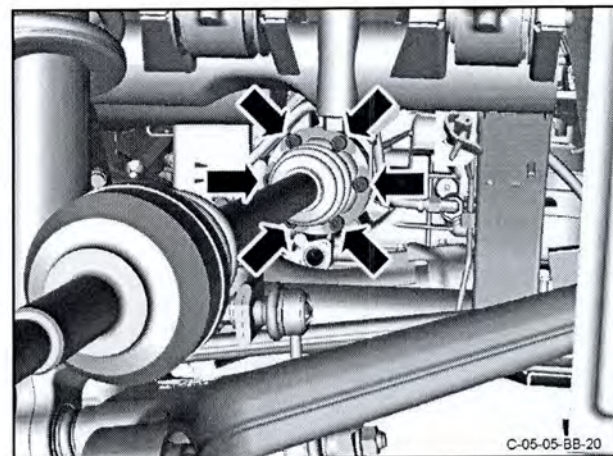

Figure 14

23. Disconnect the breather pipe from the transaxle and move the pipe away (refer to Figure 15).

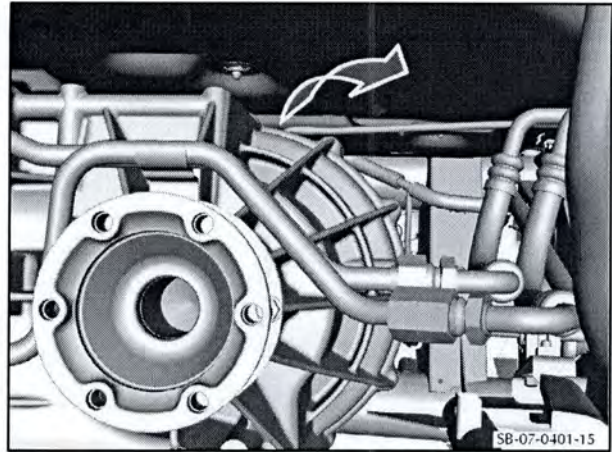

Figure 15

24. Put a transmission lift below the transaxle.
25. Adjust the height of the transmission lift to hold the weight of the transaxle.
26. Remove the nut that attaches the right side transaxle mount to the rear subframe (refer to Figure 16).

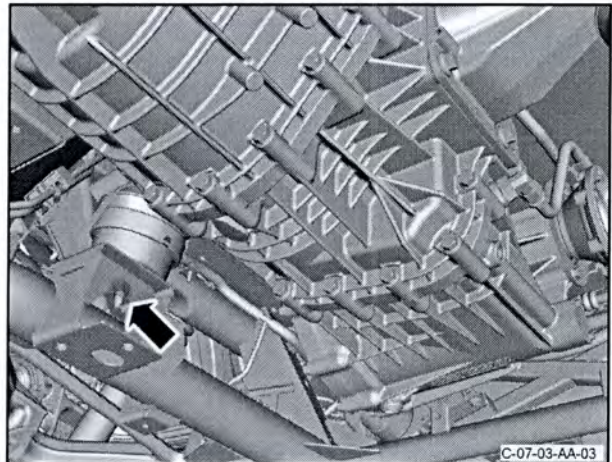

Figure 16

27. Remove the nut that attaches the left side transaxle mount to the rear subframe (refer to Figure 17).

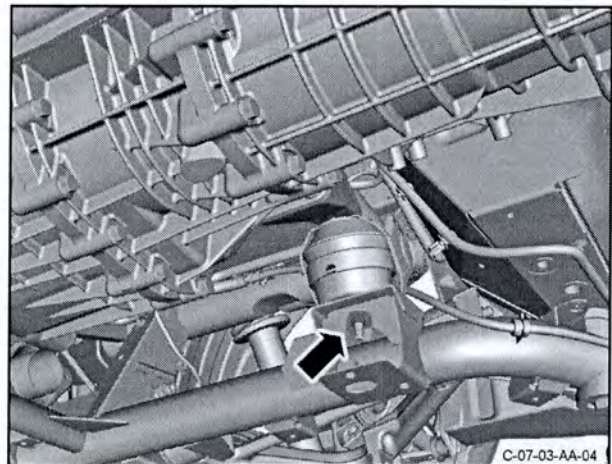

Figure 17

28. Remove and discard the four bolts that attach the right side transaxle mount bracket to the transaxle. Remove the mount bracket with the hydramount attached.

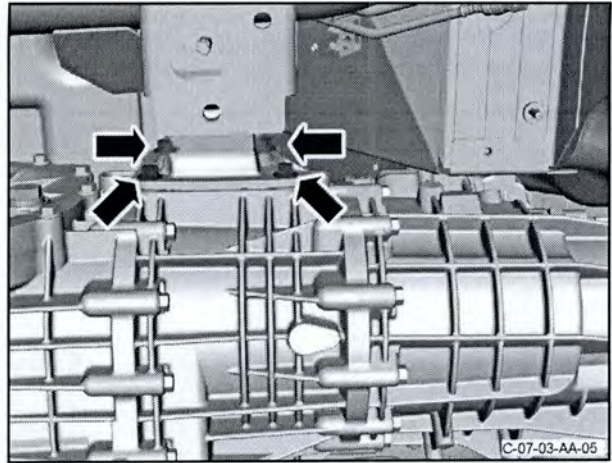

Figure 18

29. Release the reservoir hose (1) from the two clips (2) that attach it to the left side mount bracket (refer to Figure 19).

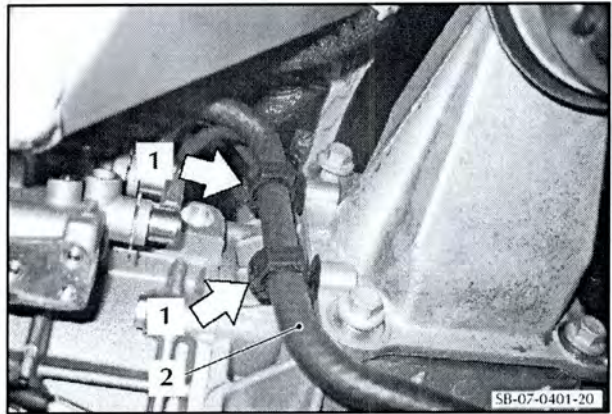

Figure 19

30. Remove the screw (1) to release the clamp (2) that attaches the fluid reservoir (3) (refer to Figure 20).
31. Remove the clamp (2) and move the reservoir (3) away.



Figure 20

32. Remove the two screws that attach the reservoir mounting bracket to the transaxle mount bracket and remove the reservoir mounting bracket.

33. Remove and discard the four bolts that attach the left side mount bracket to the transaxle. Remove the mount bracket with the hydramount attached (refer to Figure 21).

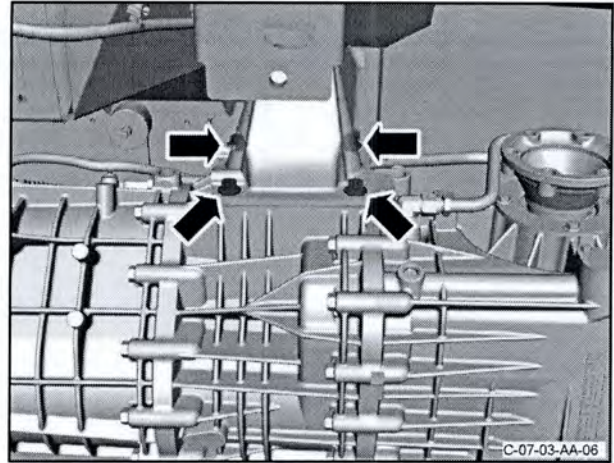

Figure 21

34. Release the drive shafts from the transaxle and move them away.
35. Use the transmission lift to lower the transaxle sufficiently to get access to the clip (1) that attaches the electrical harness (2) to the subframe (3). Release the clip (1) from the subframe (2) (refer to Figure 22).

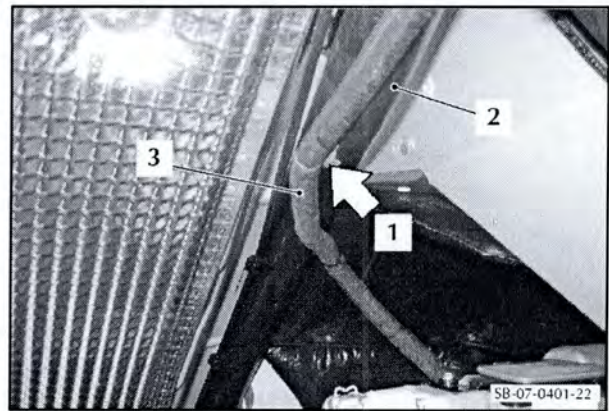

Figure 22

36. Lower the transaxle to approximately 420 mm from the installed position and use applicable straps to hold it onto the hydraulic lift.
37. Remove the clip (1) (if it is still installed) that holds the clutch hose connector (2) together at the joint between the transaxle and the torque tube (refer to Figure 23).
38. Disconnect the hose (2).

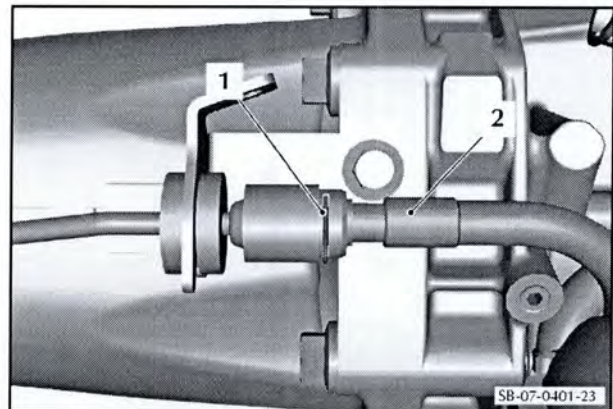
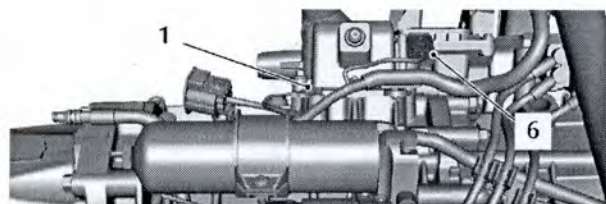

Figure 23

39. Remove the screw that attaches each of the two ground connections (1 and 2) to the transaxle (refer to Figure 24).
40. Release the clip (3) that attaches the electrical harness.



41. Disconnect the electrical connector (4) from the ASM pump.
42. Disconnect the five electrical connectors (5) from the valve block.
43. Disconnect the electrical connector (6) from the control module.
44. Move the electrical harness away from the transaxle.
45. Put an applicable support in position to hold the torque tube.
46. Use applicable straps to attach the torque tube to the transmission lift.

Figure 24

WARNING: THE TRANSAXLE ASSEMBLY IS VERY HEAVY. GET THE AID OF ONE MORE PERSON WHEN YOU MOVE THE TRANSAXLE. IF YOU DO NOT, PERSONAL INJURY CAN OCCUR.

47. Remove the eight bolts that attach the transaxle to the torque tube (refer to Figure 25).
48. Move the transaxle rearward to give clearance between the torque tube and the transaxle.
49. Remove the transaxle.

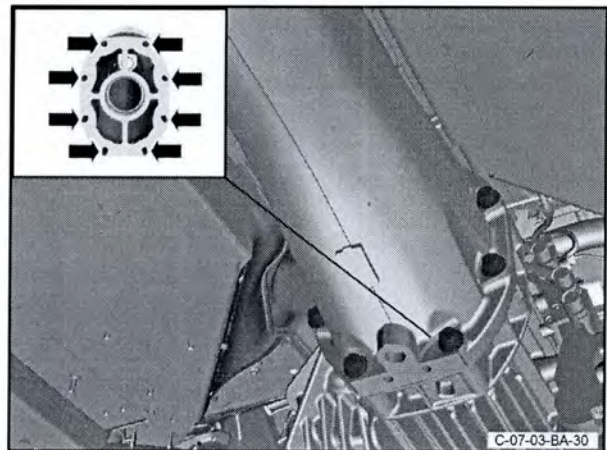

Figure 25

Part B – Remove the torque tube assembly

50. Remove the circlip that keeps the propeller shaft in the torque tube (refer Figure 26).

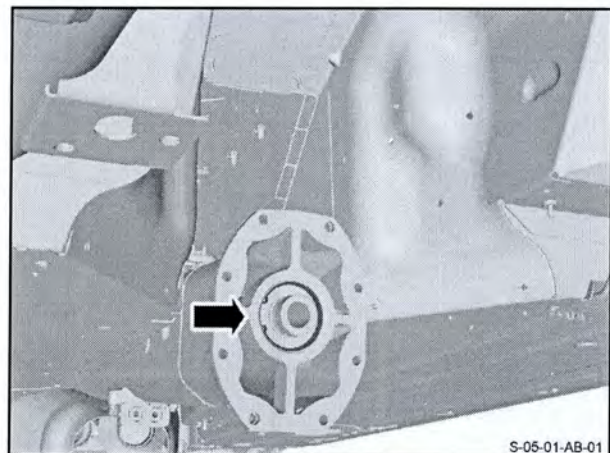

Figure 26

CAUTION: THE PROPELLER SHAFT IS LARGE. GET THE AID OF ONE MORE PERSON WHEN YOU REMOVE THE PROPELLER SHAFT. IF YOU DO NOT, DAMAGE CAN OCCUR.

CAUTION: BE CAREFUL WHEN YOU REMOVE THE PROPELLER SHAFT. YOU CAN EASILY DAMAGE THE SPLINES IN THE CLUTCH WHEN YOU REMOVE THE PROPELLER SHAFT.

- 51. Carefully remove the propeller shaft from the torque tube (refer to Figure 27).

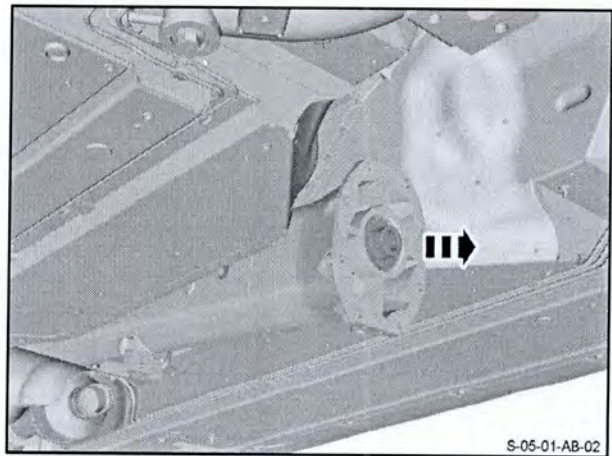

Figure 27

- 52. Remove the nut that attaches the heat shield for the front floor to the body (refer to Figure 28).

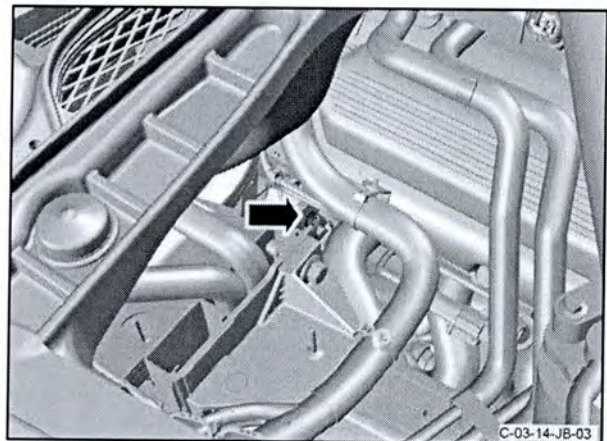

Figure 28

- 53. Remove the nut that attaches the heat shield for the front floor to the body Figure 29.

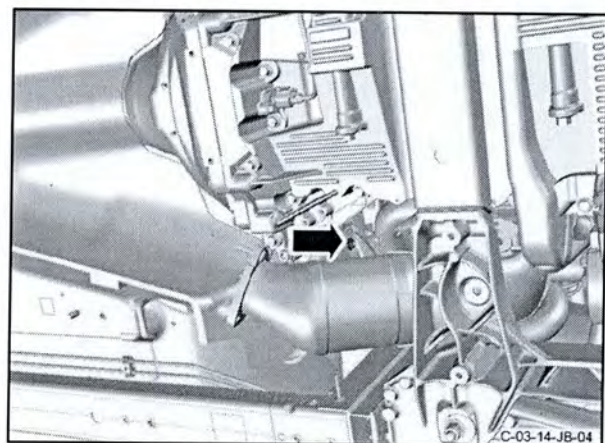

Figure 29

S-05-01-AB-02

C-03-14-JB-03

C-03-14-JB-04

54. Remove the two screws (1) that attach the front of the heat shield (2) for the front floor to the torque tube (refer to Figure 30).
55. Remove the two screws (3) that attach the rear of the heat shield (2) to the torque tube and remove the heat shield (2).

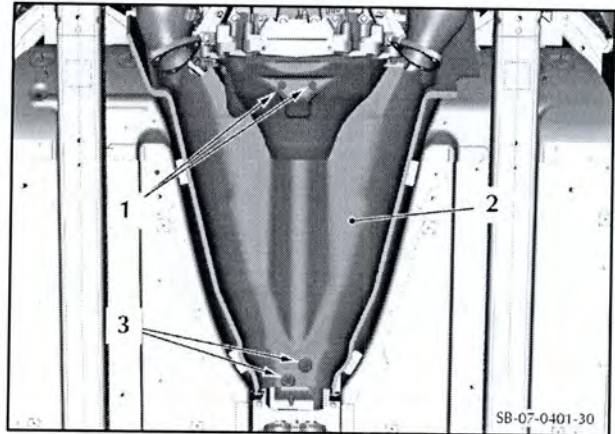

Figure 30

56. Disconnect the electrical connector from the speed sensor for the propeller shaft (refer to Figure 31).

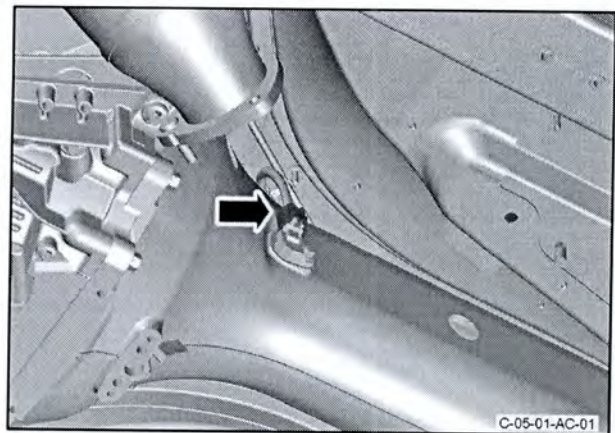

Figure 31

57. Lower the transmission jack to lower the rear end of the torque tube until you can get access to the 16 torque tube attachment bolts.
58. Remove the 16 bolts that attach the torque tube to the engine and remove the torque tube (refer to Figure 32).

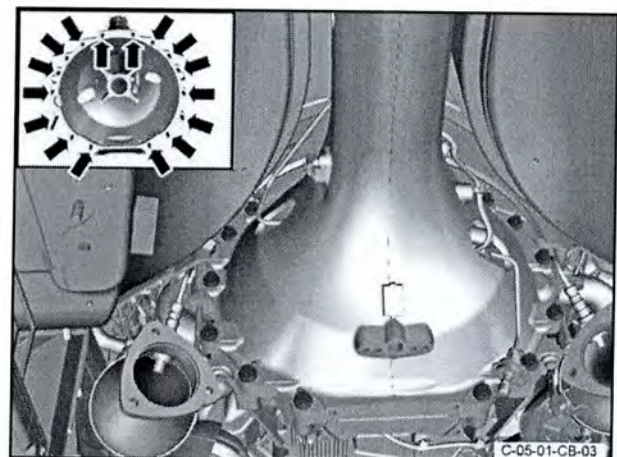

Figure 32

WARNING: THE TORQUE TUBE IS LARGE AND HEAVY. GET THE AID OF ONE MORE PERSON WHEN YOU REMOVE THE TORQUE TUBE. IF YOU DO NOT, PERSONAL INJURY CAN OCCUR.

59. Remove the torque tube.

Part C – Change the supply tube assembly for the concentric slave cylinder

60. Remove the clip (1) that attaches the connector (2) for the clutch fluid tube assembly (tube assembly) to the concentric slave cylinder (3) (cylinder) (refer to Figure 33).
61. Disconnect the tube assembly (2) from the cylinder (3).

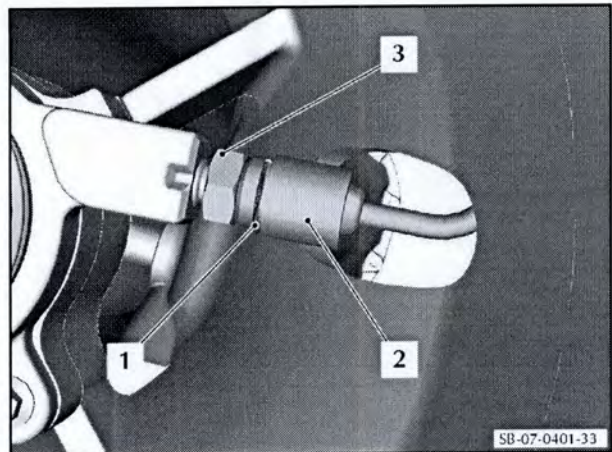

Figure 33

62. Remove the screw (1) that attaches the attachment bracket (2) for the tube assembly (3) to the torque tube (refer to Figure 34).

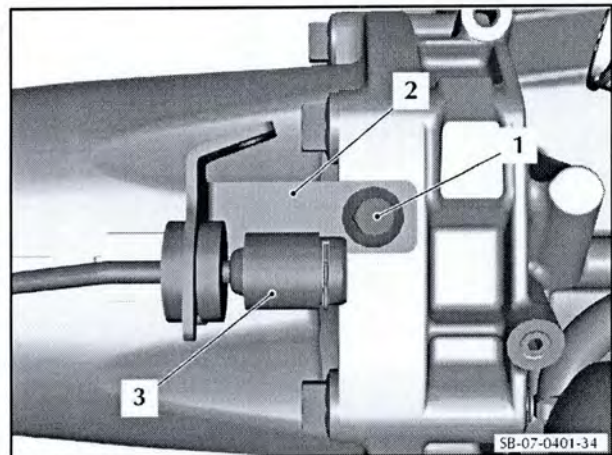

Figure 34

63. Release the tube assembly from the clips that attach it to the torque tube.
64. Discard the tube assembly.
65. Install the new tube assembly (refer to Part Data) into the clips on the torque tube.
66. Connect the tube assembly (2) to the concentric slave cylinder (3) (refer to Figure 35).
67. Install a new clip (1) to attach the tube assembly (2) to the concentric slave cylinder (3).

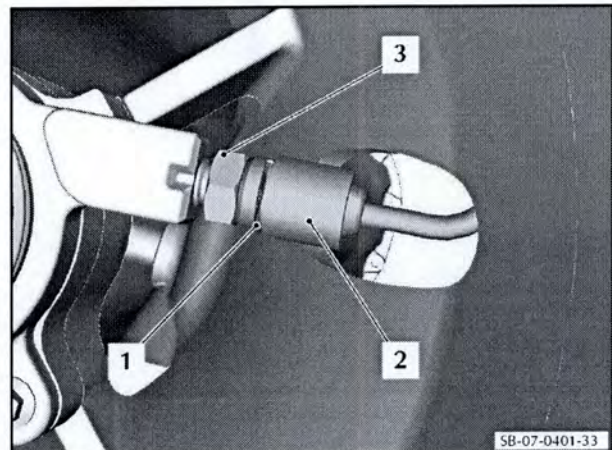

Figure 35

Part D – Change the hose for the dry break connector

68. On the transaxle assembly, remove the clip (1) that attaches the clutch fluid hose (2) into the valve block (3) (refer to Figure 36).
69. Disconnect the clutch fluid hose (2) from the valve block (3).
70. Discard the clutch fluid hose (2).
71. Install the new hose (2) from the EVO pipe kit C (refer to Part Data).
72. Install the new retaining clip (1) to hold the hose (2) into the valve block (3).

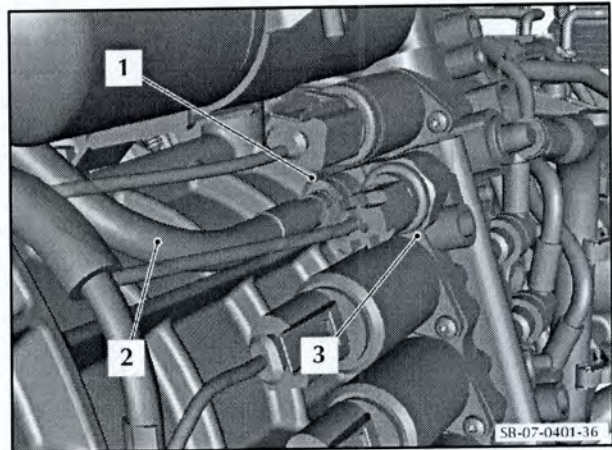

Figure 36

Part E – Install the torque tube assembly

WARNING: THE TORQUE TUBE IS LARGE AND HEAVY. GET THE AID OF ONE MORE PERSON WHEN YOU INSTALL THE TORQUE TUBE. IF YOU DO NOT, PERSONAL INJURY CAN OCCUR.

73. Clean the mating faces between the torque tube and the engine.
74. Align the torque tube assembly with the engine.
75. Install the 16 bolts that attach the torque tube assembly to the engine (refer to Figure 37).
76. Torque the 16 bolts to 50 Nm.

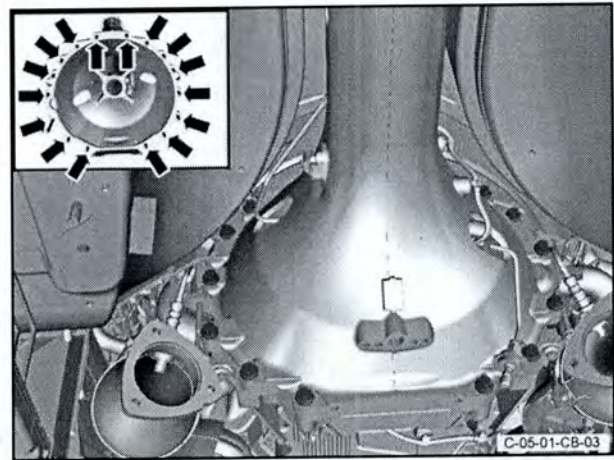

Figure 37

77. Connect the electrical connector to the speed sensor for the propeller shaft (refer to Figure 38).

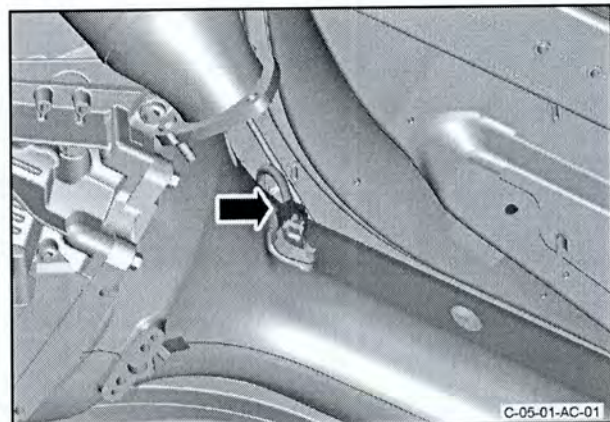

Figure 38

78. Put the heat shield (2) into position (refer to Figure 39).
79. Install the two screws (3) that attach the rear of the heat shield (2) to the torque tube. Torque the two screws to 9 Nm.
80. Install the two screws (1) that attach the front of the heat shield (2) to the torque tube. Torque the two screws to 9 Nm.

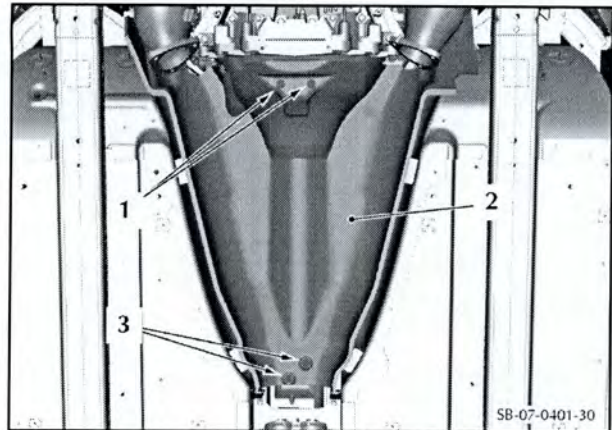

Figure 39

81. Install the nut that attaches the heat shield for the front floor to the body (refer to Figure 40). Torque the nut to 9 Nm.

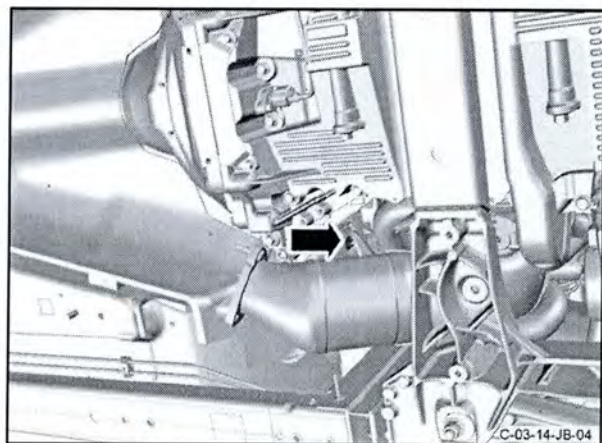

Figure 40

82. Install the nut that attaches the heat shield for the front floor, to the body (refer to Figure 41). Torque the nut to 9 Nm.

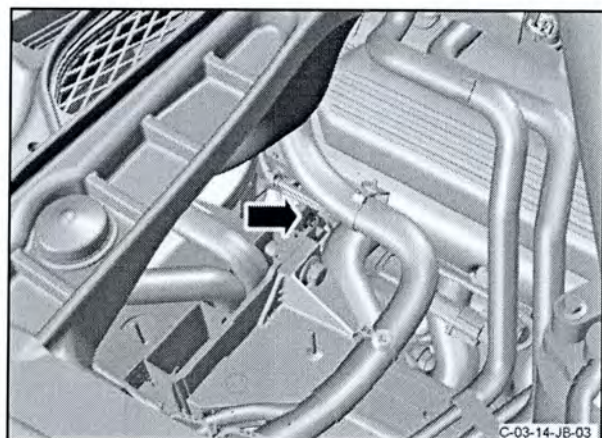

Figure 41

WARNING: THE PROPELLER SHAFT IS LARGE. GET THE AID OF ONE MORE PERSON WHEN YOU INSTALL THE PROPELLER SHAFT. IF YOU DO NOT, DAMAGE OR INJURY CAN OCCUR.

CAUTION: BE CAREFUL WHEN YOU INSTALL THE PROPELLER SHAFT. YOU CAN EASILY DAMAGE THE SPLINES IN THE CLUTCH WHEN YOU INSTALL THE PROPELLER SHAFT.

83. Carefully install the propeller shaft into the torque tube and engage the splines of the propeller shaft in the clutch (refer to Figure 42).

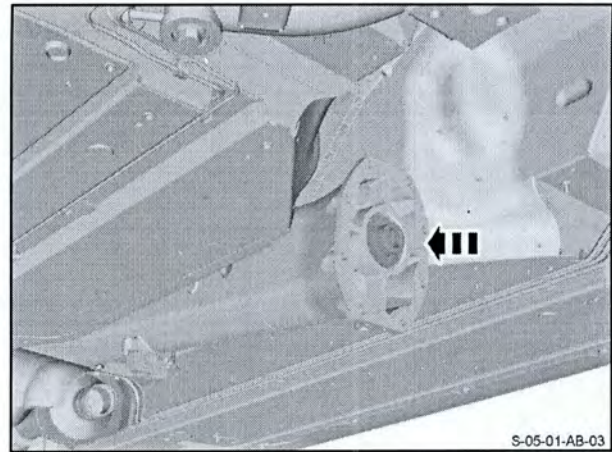

Figure 42

84. Remove the circlip that keeps the propeller shaft in the torque tube (refer Figure 43).

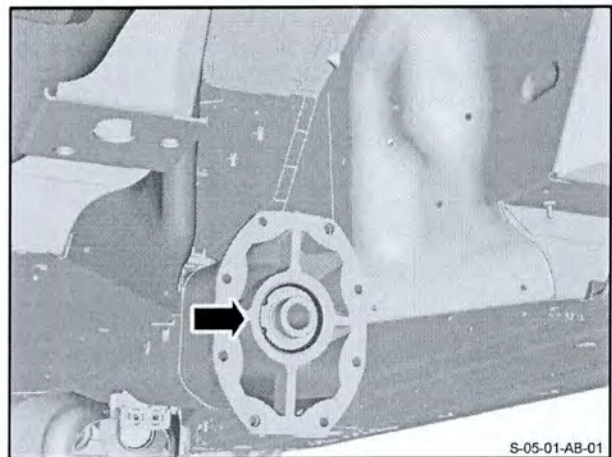

Figure 43

Part F – Install the transaxle assembly

85. Align the transaxle assembly with the torque tube
86. Install six of the eight bolts that attach the transaxle to the torque tube (refer to Figure 25).

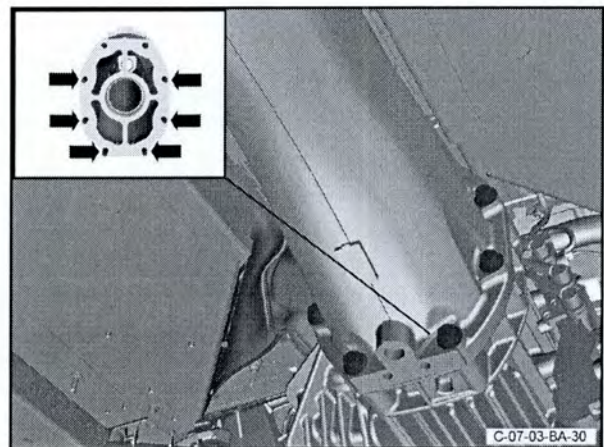

Figure 44

- 87. Put the new bracket assembly (1) for the transmission tube in position. Align the bracket with the two remaining holes in the torque tube (refer to Figure 45).
- 88. Install the last two bolts (2) that attach the transaxle to the torque tube.
- 89. Tighten the eight bolts that attach the transaxle to the torque tube to 50 Nm.
- 90. Connect the tube assembly for the concentric slave cylinder (3) to the bracket assembly (1).

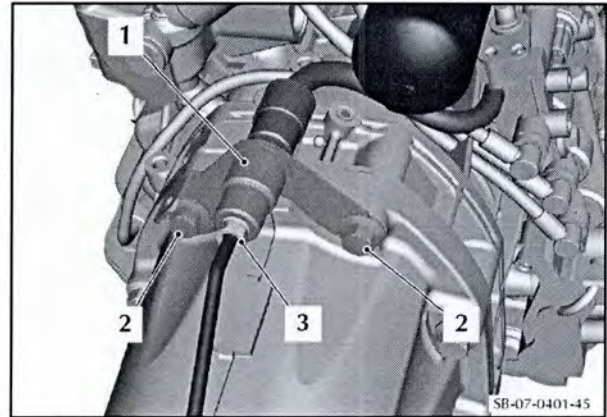

Figure 45

- 91. Connect the dry-break connector to the tube assembly for the clutch slave cylinder (refer to Figure 46). Make sure that the locking collar for the connector is in the correct position shown in view A of Figure 47. View B shows a connector that is not correctly connected.

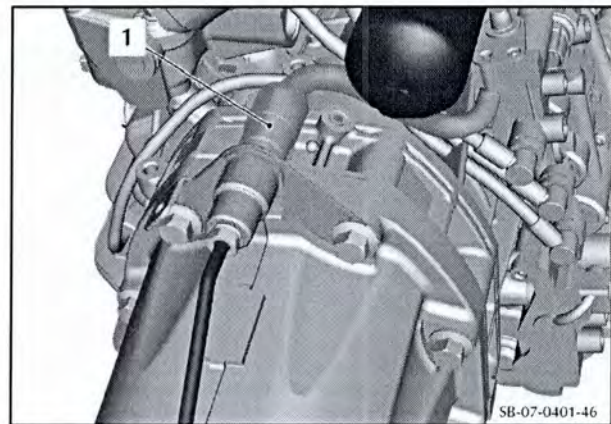

Figure 46

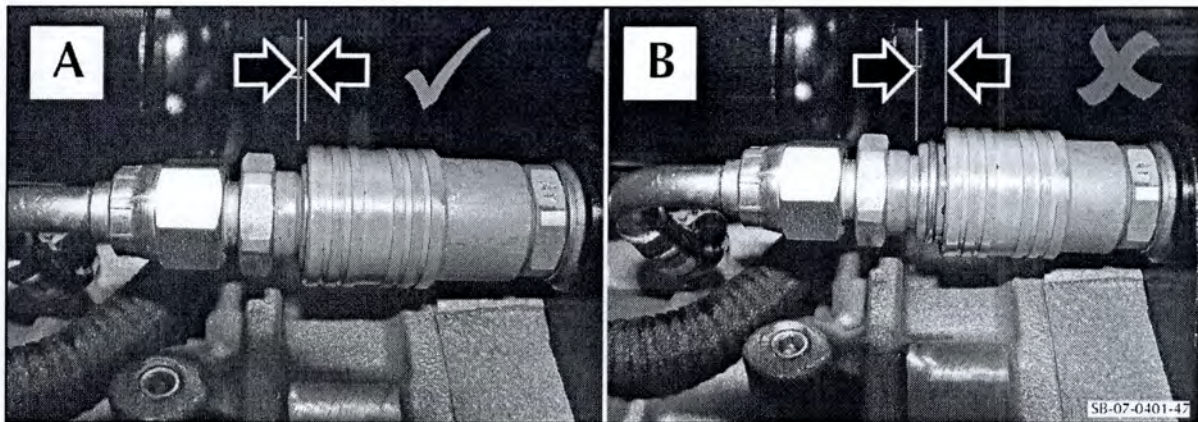

Figure 47

- 92. Use the transmission lift to start to lift the transaxle and torque tube assembly until you can put the electrical harness into the correct position.

93. Connect the electrical connector (6) to the control module (refer to Figure 48).
94. Connect the five electrical connectors (5) to the valve block.
95. Connect the electrical connector (4) to the ASM pump.
96. Install the clip (3) that attaches the electrical harness.
97. Install the screws that attach each of the two ground connections (1 and 2) to the transaxle.

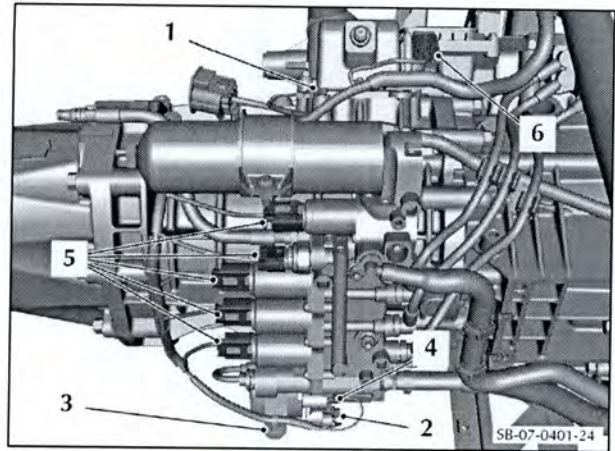

Figure 48

98. Use the transmission lift to lift the transaxle sufficiently to install the clip (1) that attaches the electrical harness (2) to the subframe (3) (refer to Figure 49).

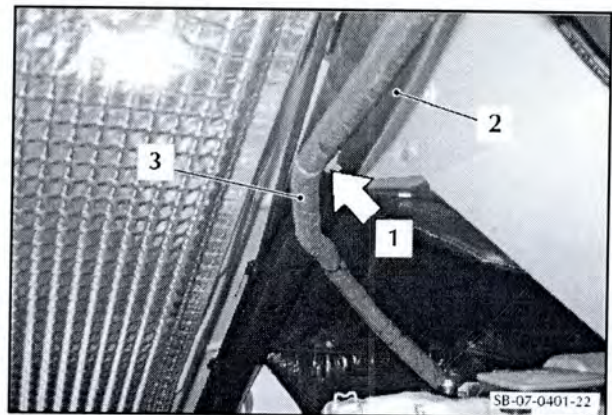

Figure 49

99. Put the left mount bracket, with the hydramount attached, in position (refer to Figure 50).
100. Install four new bolts to attach the left side mount bracket to the transaxle. Torque the bolts to 63 Nm.

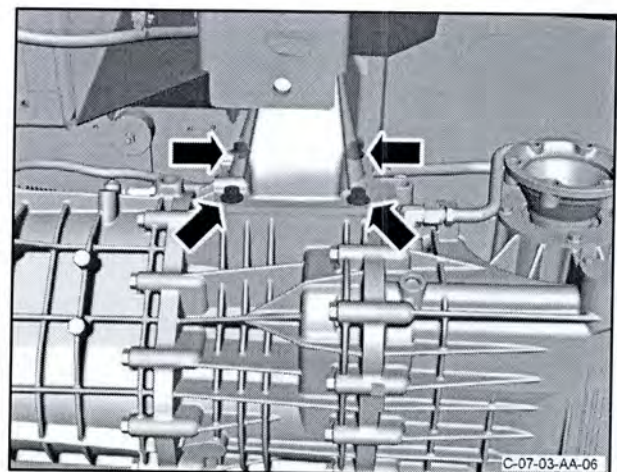

Figure 50

101. Remove the two screws that attach the reservoir mounting bracket to the transaxle mount bracket and remove the reservoir mounting bracket.

102. Put the reservoir (3) in position (refer to Figure 51).
103. Put the clamp (2) in position to hold the reservoir (3).
104. Install the screw (1) to attach the clamp (2) that attaches the fluid reservoir (3).



Figure 51

105. Put the reservoir hose (1) into position in the two clips (2) that attach it to the left side mount bracket (refer to Figure 52). Close the clips (1) to attach the hose.

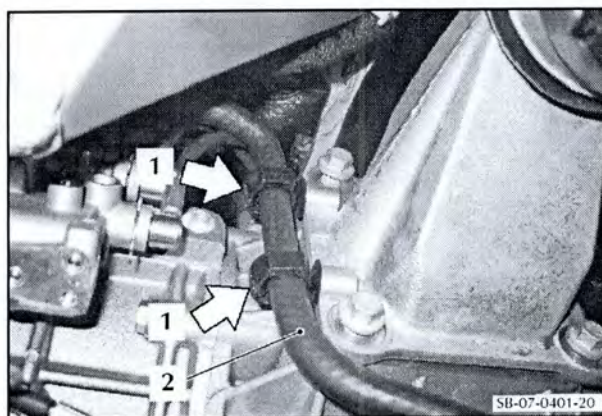

Figure 52

106. Put the right mount bracket with the hydramount attached into position (refer to Figure 53).
107. Install four new bolts to attach the right side mount bracket to the transaxle. Torque the bolts to 63 Nm.

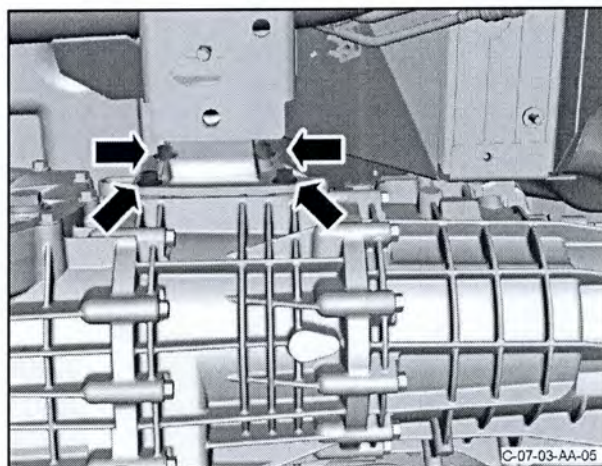

Figure 53

108. Install the nut that attaches the left side transaxle mount to the rear subframe (refer to Figure 54). Torque the nut to 48 Nm.

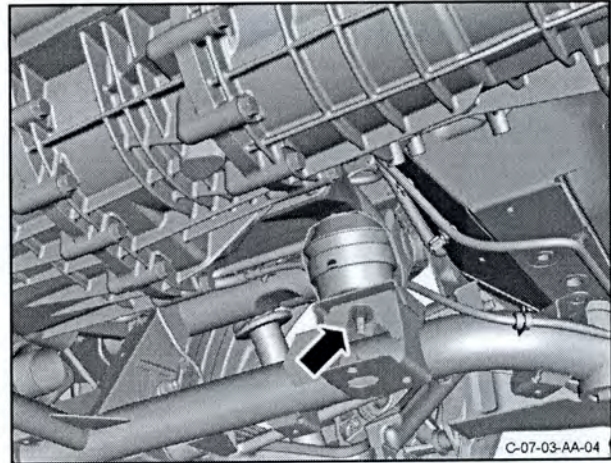

Figure 54

109. Install the nut that attaches the right side transaxle mount to the rear subframe (refer to Figure 55). Torque the nut to 48 Nm.

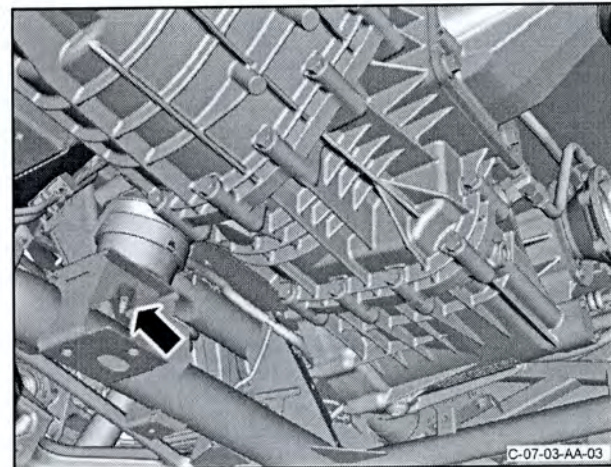

Figure 55

110. Remove the transmission lift.
111. Install the breather pipe for the transaxle (refer to Figure 56).

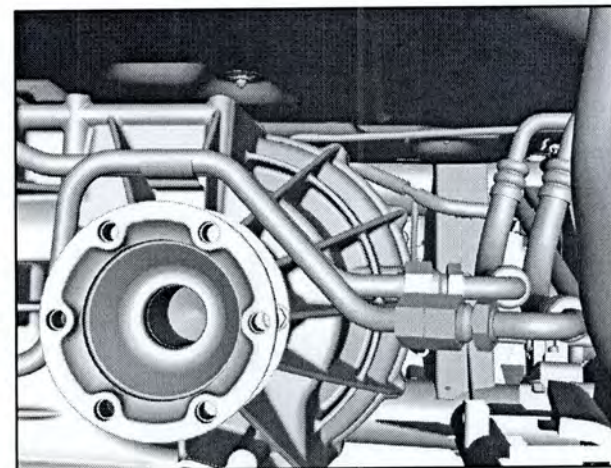

Figure 56

112. Put the right side drive shaft flange in position on the transaxle shaft (refer to Figure 57). Align the marks on the drive shaft flange that you made during step 20.
113. Install six new Allen head bolts and the three locking plates to attach the right drive shaft flange to the transaxle shaft.

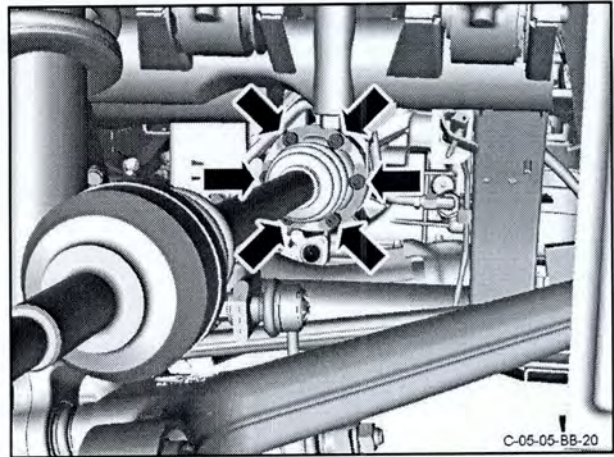

Figure 57

114. Put the left side drive shaft flange in position on the transaxle shaft (refer to Figure 58). Align the marks on the drive shaft flange that you made during step 20.
115. Install six new Allen head bolts and the three locking plates to attach the left drive shaft flange to the transaxle shaft.

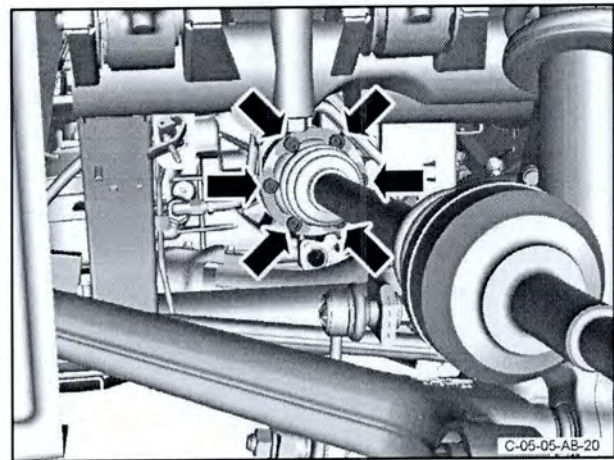

Figure 58

116. Install the bolt (1) that attaches the ground cable (2) to the transmission mount bracket (3) (refer to Figure 59).

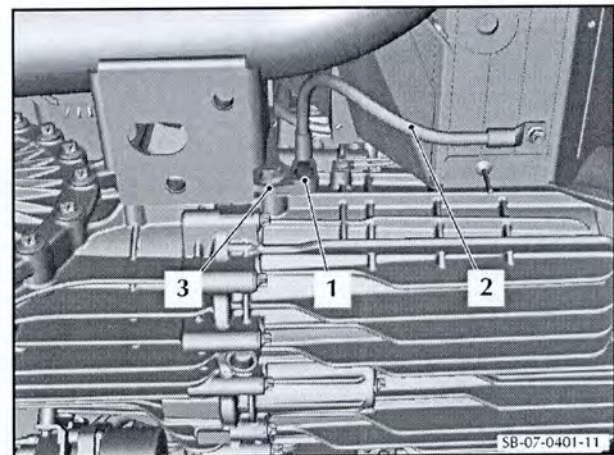

Figure 59

117. Fill the transaxle with fluid (refer to Workshop Manual procedure 07.03.BC).

118. Put the tunnel reinforcement plate in position (refer to Figure 60).
119. Install the eight bolts (1) that attach the tunnel reinforcement plate (2) to the body. Torque the eight bolts to 9 Nm.

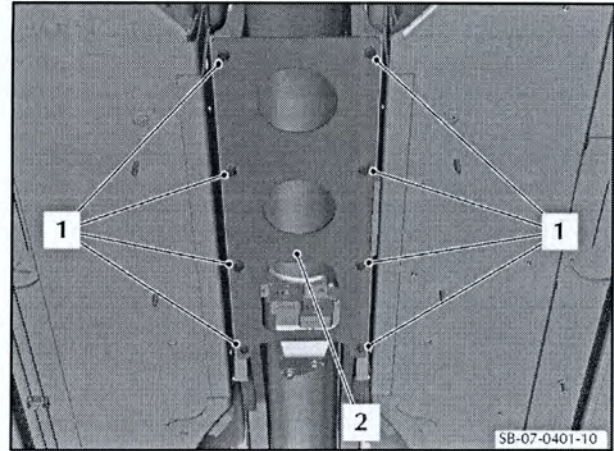

Figure 60

120. Put the tunnel heatshield (2) into position (refer to Figure 61).
121. Install the four bolts and four washers (1) that attach the tunnel heatshield (2) to the body. Torque the four bolts to 23 Nm.

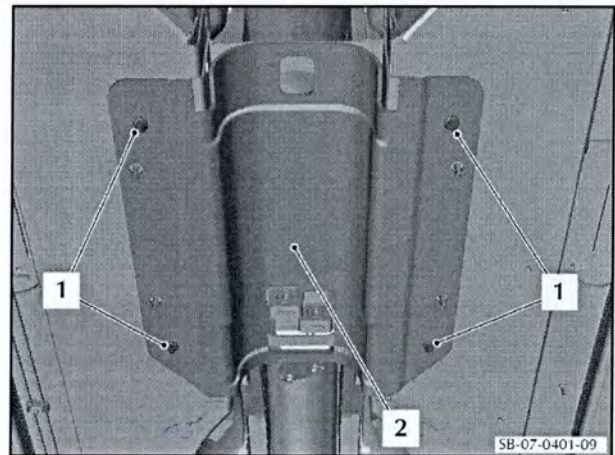

Figure 61

122. Install the exhaust centre brace assembly (refer to Figure 62).

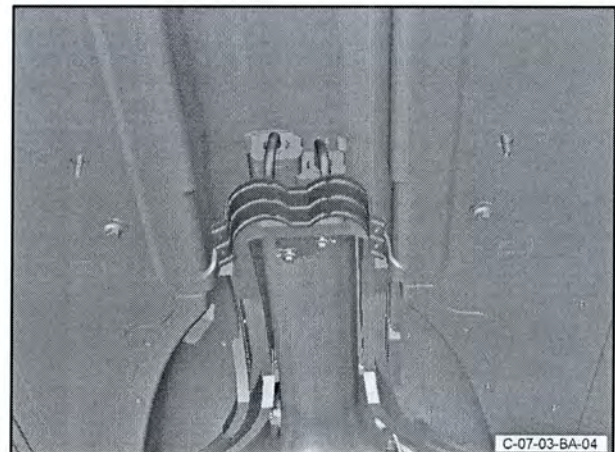

Figure 62

123. Put a new sealing ring in position in each joint between the centre pipe and the muffler.

124. Install the centre and rear exhaust pipes as an assembly (refer to Figure 63).

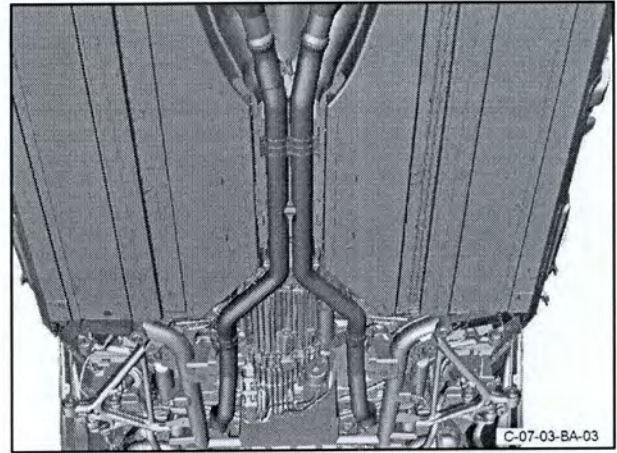

Figure 63

125. Install the four bolts that attach the centre exhaust pipe to the exhaust front mount (refer to Figure 64). Torque the four bolts to 9 Nm.

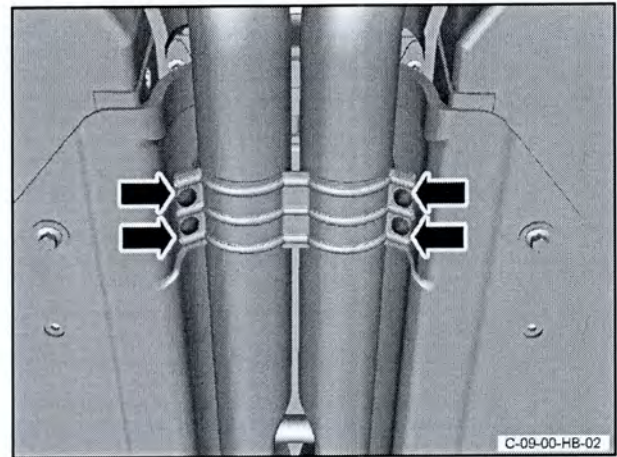

Figure 64

126. Apply an applicable sealing paste to the joints between the two catalytic converters and the pipe assemblies.
127. Move the two clamps (1) into the correct positions on the catalytic converters and pipe assemblies (refer to Figure 65).
128. Tighten the clamp bolt (2) on each of the two clamps (1).

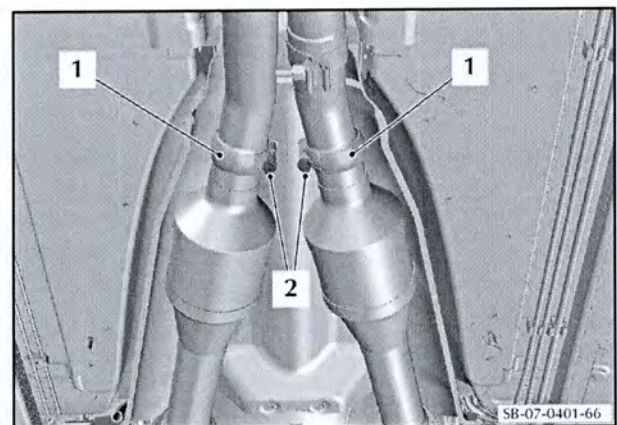

Figure 65

- 129. Install the four bolts and four springs that attach the exhaust centre pipe to the muffler and bypass valve assembly (refer to Figure 66). Torque the four bolts to 30 Nm.

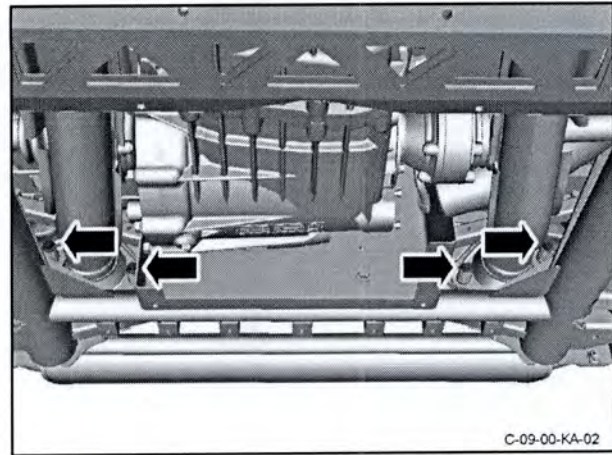

Figure 66

- 130. Hold the cross brace (2) in position (refer to Figure 67).
- 131. Install the four screws (1) that attach the cross brace (2). Torque the four bolts to 71 Nm.

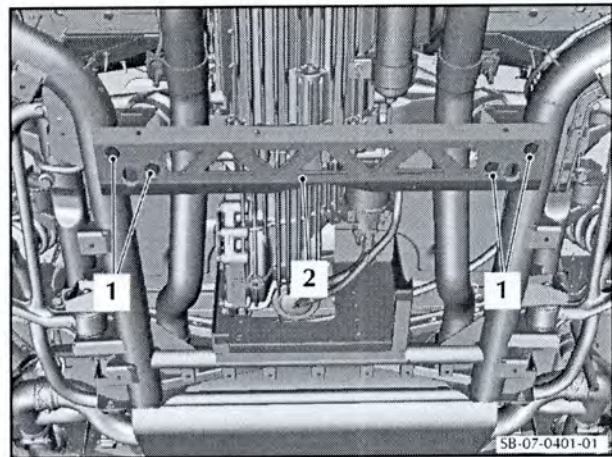

Figure 67

- 132. Lower the vehicle.
- 133. Do the battery connect procedure (refer to Workshop Manual procedure 14.01.CA).
- 134. Do the clutch bleed procedure (refer to Workshop Manual procedure 08.00.AE).
- 135. Install the rear undertray (refer to Workshop Manual procedure 01.02.PB)

Part Data

Description	Part Number	Quantity
Tube Assembly, Master to Slave Cylinder.	6G33-7K502-AA	1
Bracket Assembly, Transmission Tube	6G33-7J200-AB	1
EVO Pipe Kit C, Dry Break Connector	6G33-7J327-AA	1
Clutch Line Bracket	6G33-R7N630-CE	1

Warranty Data

Procedure and Labour Time

Description	Labour Time
Replace the ASM clutch tube assembly.	6.5 hours

Failure Mode Description

Select the failure mode that follows when you make a claim through the Warranty system:

Subsystem	Location	Component	Mode of Failure
Powertrain	Drivetrain - Transmission - ASM	Manual Transmission - Clutch - Pipe (Rigid)	Leaking - Connection

If you have any questions related to this Service Bulletin, please contact: Aston Martin Technical Services
on: +44 (0) 1926 644720, email: askamtech@astonmartin.com,
or contact your After Sales Manager.

The English version of this Service Bulletin is written in
Simplified Technical English to ASD-STE100™.