



Countries:	RUSSIA, AUSTRALIA, BRAZIL, UNITED STATES, MEXICO, PUERTO RICO, NEW ZEALAND, SOUTH AFRICA	Document ID:	IK0400125
Availability:	ISIS	Revision:	2
Major System:	BRAKES	Created:	7/2/2013
Current Language:	English	Last Modified:	2/6/2015
Other Languages:	NONE	Author:	James Santos
Viewed:	363		

[Less Info](#)

Hide Details

Coding Information

Copy Link 	Copy Relative Link 	Bookmark View My Bookmarks	Add to Favorites 	Print 	Provide Feedback 	Helpful 5	Not Helpful 0
----------------------	-------------------------------	--	-----------------------------	------------------	-----------------------------	-------------------------	-----------------------------

Title: Rear S Cam Tube/ Bracket part update

Applies To: Prostar, CAT, LoneStar, Durastar, WorkStar, TranStar

DESCRIPTION

Part update for cast and stamped Rear S Cam Brackets. Revised parts will include additional gusset for rear wing bracket and/ or longer gussets and wrap around weld on the flange side of the tube.

Parts information below is based off previous part number and crossed to the new number. **If the part number for your VIN is not listed below DO NOT SUBSTITUTE to the new numbers. Brackets are specific in length and clocking to each vehicle application.**

PARTS INFORMATION

Typical For Cast Spider (New)
(New)

Typical for Stamped Spider



OLD Meritor Part Number		OLD Navistar Part Number		NEW Meritor Part Number		NEW Navistar Part Number	
G9 3299P6256	G9 3299Q6257	1698379C91	1698390C91	T68 3299P6256	T68 3299Q6257	2511737C91	2511738C91
M5 3299P6256	M5 3299Q6257	2509758C91	2509760C91	T67 3299P6256	T67 3299Q6257	2511739C91	2511740C91
M10 3299P6256	M10 3299Q6257	2508938C91	2508941C91	T69 3299P6256	T69 3299Q6257	2511741C91	2511742C91
F38 3299P6256	F38 3299Q6257	2596616C91	2596618C91	U23 3299P6256	U23 3299Q6257	2512102C91	2512103C91
M43 3299P6256	M43 3299Q6257	2585527C91	2585528C91	T50 3299P6256	T50 3299Q6257	2512124C91	2512075C91
F89 3299P6256	F89 3299Q6257	1698120C91	1698122C91	U21 3299P6256	U21 3299Q6257	2512122C91	2512123C91
M22 3299P6256	M22 3299Q6257	2509295C91	2509296C91	U20 3299P6256	U20 3299Q6257	2512118C91	2512119C91
K88 3299P6256	K88 3299Q6257	2505794C91	2505800C91	U24 3299P6256	U24 3299Q6257	2512120C91	2512121C91

E82 3299P6256	E82 3299Q6257	1694330C91	1694332C91	U25 3299P6256	U25 3299Q6257	2512076C91	2512077C91
D11 3299P6256	D11 3299Q6257	584922C91	584923C91	U26 3299P6256	U26 3299Q6257	2512078C91	2512079C91

NOTE: On certain wide base axle applications the new SCAM gusseted bracket will come into contact with the old support brackets it will be necessary to order and relocate new s-cam Support bracket to the out board side of the U-bolt (Bolt closest the wheel).

If replacing passenger side (right side) s-cam bracket you will need new s-cam support bracket part # 3668032C1

If replacing Driver Side (left side) s-cam bracket you will need new s-cam support bracket part # 3668033C1

Service Procedure

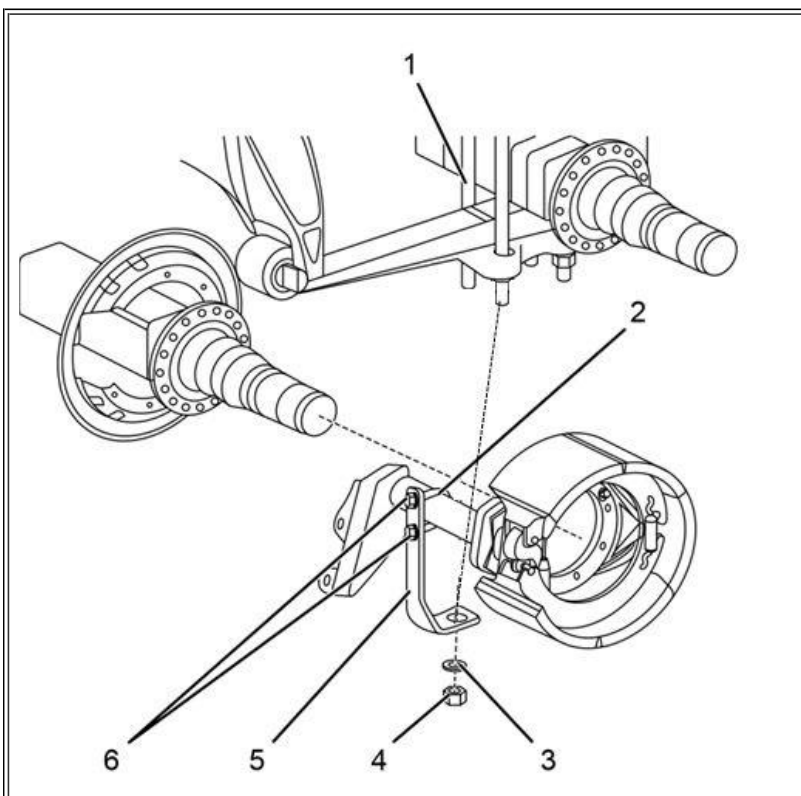

Figure #1: Cam Tube

1. U-bolt
2. Exhaust pipe clamp
3. Washer (U-bolt)
4. Nut (U-bolt)
5. Cam tube support bracket
6. Nut and washer

1. To ensure proper installation of cam tube support bracket, perform the following:

- a. Slide new cam tube support bracket (Figure 1, Item 5) over U-bolt (Figure 1, Item 1)
- b. Position exhaust pipe clamp (Figure 2, Item 2) on cam tube support bracket (Figure 2, Item 5) and through cam tube support bracket slots with two washers and nuts

(Figure 2, Item 1) hand tight.

c. Ensure cam tube support bracket (Figure 2, Item 5) is contacting cam tube (Figure 2, Item 3) and is sitting flush against rear U-bolt spring plate (Figure 2, Item 4).

d. Using torque wrench, tighten two nuts (Figure 2, Item 1) to 60 - 72 lb-in (6.8 - 8.1 N•m).

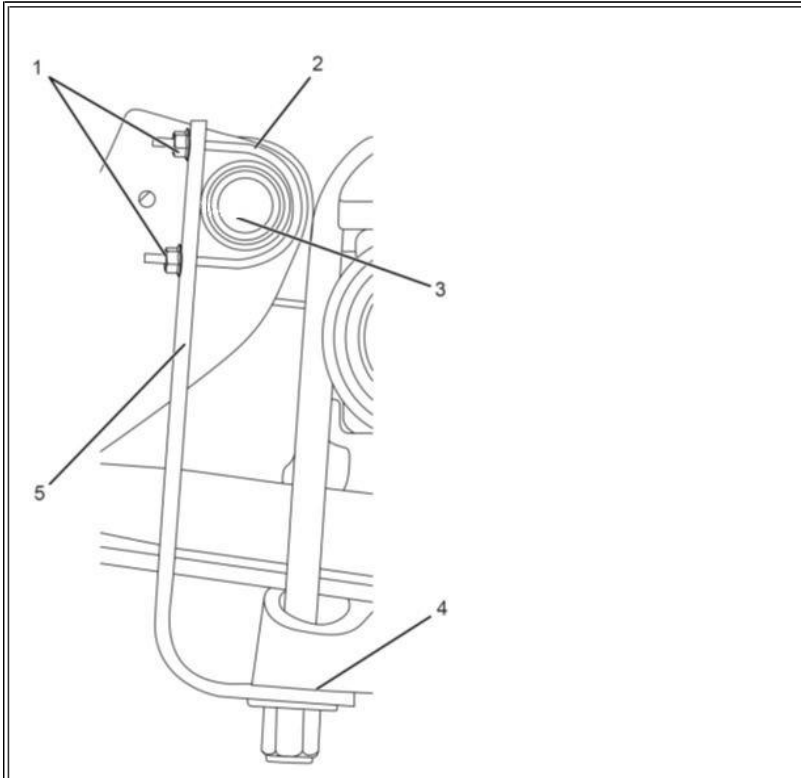

Figure # 2: Support Bracket

1. Nut and washer
2. Exhaust pipe clamp
3. Cam tube
4. Rear U-bolt spring plate
5. Cam tube support bracket

2. Install new washer U-bolt using torque wrench, tighten nut to 200 lb-ft (271 N•m)

3. Using torque wrench, tighten four bolts in diagonal pattern to 300 lb-ft (405 N•m)

4. Using torque wrench, tighten four nuts in diagonal pattern to final torque of 375 lb-ft (508 N•m)

5. If torque is not achieved, replace U-bolt.

Refer to Meritor Cam Brake maintenance manual for remove and install instructions on S-CAM brackets

Torque Specifications

Cam Brakes

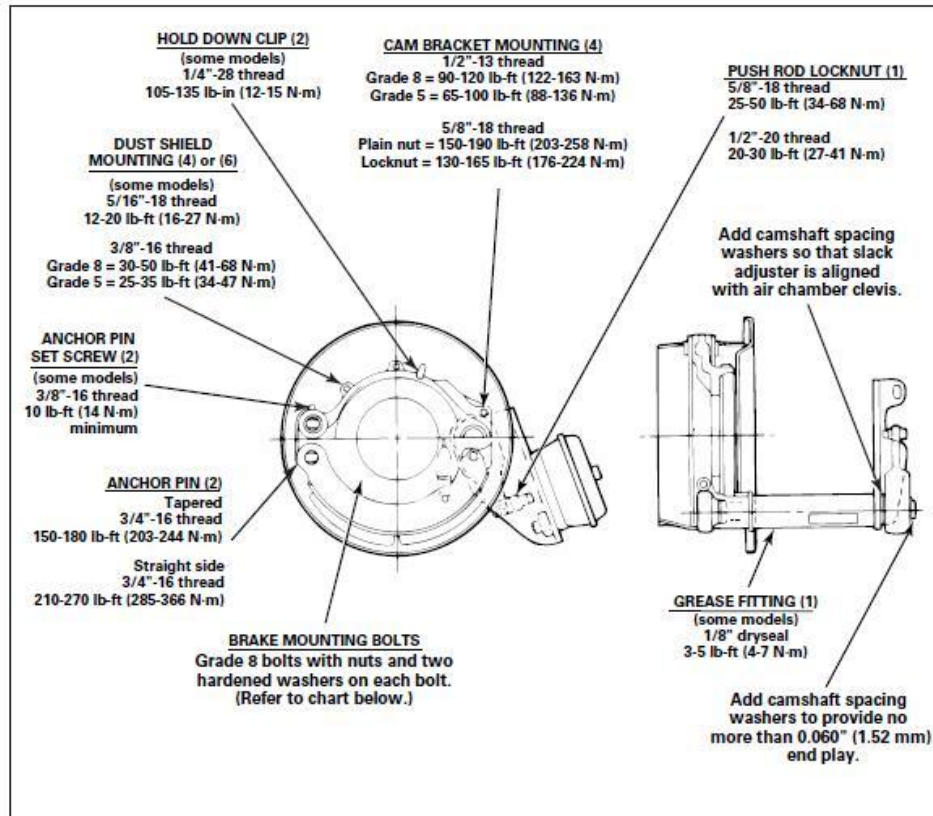

Brake Mounting Bolts

Bolt Size, Grade 8	Torque, lb-ft (N-m)
7/16"-20	60-75 (81-102)
1/2"-20	85-115 (115-156)
9/16"-18	130-165 (176-224)
5/8"-18	180-230 (244-312)

Standard Repair Time(s):

Description	Chassis	Engine	SRT	Hours
S-CAM Support Bracket	Pro Star	ALL	A04T1	.2
S-Cam Bracket Replacement	All	All	A04-226	.9

WARRANTY INFORMATION

Warranty Claim Coding:

Group:	04092- Tractor Air Brakes
Noun:	105 - Bracket/ Chamber

 Hide Details

Feedback Information

Viewed: 362
Helpful: 5
Not Helpful: 0

No Feedback Found

Copyright © 2015 Navistar, Inc.