

**NUMBER:** 02-005-15 REV. B**GROUP:** Front Suspension**DATE:** April 30, 2015

This bulletin is supplied as technical information only and is not an authorization for repair. No part of this publication may be reproduced, stored in a retrieval system, or transmitted, in any form or by any means, electronic, mechanical, photocopying, or otherwise, without written permission of FCA US LLC.

THIS BULLETIN SUPERSEDES SERVICE BULLETIN 02-005-15 REV. A, DATED APRIL 23, 2015, WHICH SHOULD BE REMOVED FROM YOUR FILES. ALL REVISIONS ARE HIGHLIGHTED WITH **ASTERISKS**** AND INCLUDE BECOMING A RAPID RESPONSE TRANSMITTAL (RRT) AND BULLETIN APPLICABILITY DATE RANGE HAS CHANGED.**

****THIS SERVICE BULLETIN IS ALSO BEING RELEASED AS RAPID RESPONSE TRANSMITTAL (RRT) 15-046. ALL APPLICABLE SOLD AND UN-SOLD RRT VIN'S HAVE BEEN LOADED. TO VERIFY THAT THIS RRT SERVICE ACTION IS APPLICABLE TO THE VEHICLE, USE VIP OR PERFORM A VIN SEARCH IN TECHCONNECT. ALL REPAIRS ARE REIMBURSABLE WITHIN THE PROVISIONS OF WARRANTY.****

SUBJECT:

Front End Popping Noise While Driving Over Bumps

OVERVIEW:

This bulletin involves using structural adhesive to bond the front upper shock absorber brackets to the carbon fiber structure.

MODELS:

2015 (4C) Alfa 4C

NOTE: **This bulletin applies to vehicles built on or after July 9, 2014 (MDH 0709XX) and on or before December 12, 2014 (MDH 1212XX).**

SYMPTOM/CONDITION:

The customer may describe a popping noise in the front of the vehicle while driving over bumps at low speeds.

The popping noise may be caused by movement between the front upper shock absorber mount bracket and the carbon fiber structure in the area shown in (Fig. 1).

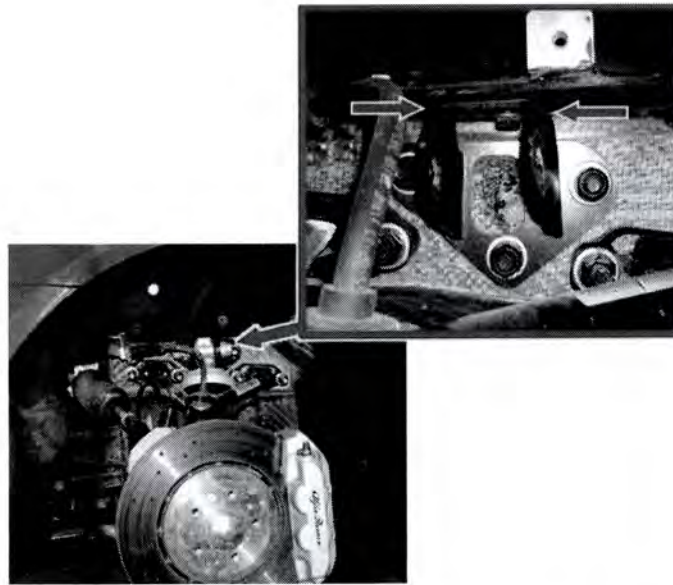

Fig. 1 Noise From Contact Area Between Shock Absorber Bracket And Structure

DIAGNOSIS:

If a customer's VIN is listed in VIP or your RRT VIN list, perform the repair. For all other customers that describe the symptom/condition listed above, perform the Repair Procedure.

PARTS REQUIRED:

Qty.	Part No.	Description
2	68236515AA	Nut M14 Shock Absorber Upper
2	68236514AA	BOLT, Hex Head M14 Shock Absorber Upper
2	68236516AA	Nut M12 Shock Absorber Lower
2	68236483AA	BOLT, Hex Head M12 Shock Absorber Lower
6	68243347AA	Nut M10 Shock Absorber Bracket
2	68236473AA	BOLT, Hex Head M8 Shock Absorber Bracket
1 (AR)	04318031	MOPAR Lock & Seal Adhesive or Material Standard CC75 equivalent
1 (AR)	NPN	LORD Fusor® 2098 Structural Adhesive = 6.59 oz (195 mL) OR 3M® 07333 Structural Adhesive = 6.75 oz (200 mL)

NOTE: Each tube of MOPAR Lock & Seal Adhesive will service approximately 6 vehicles.

NOTE: 1 cartridge of LORD Fusor® 2098 or 3M® 07333 structural adhesive will service approximately 1 vehicle.

NOTE: For LORD Fusor technical support or to find a local distributor, please call +1 800 234 FUSOR (3876).

SPECIAL TOOLS/EQUIPMENT REQUIRED:

NPN	Fusor® 313 Adhesive Dispensing Gun
NPN	3M® B26T200 Albion Adhesive Dispensing Gun

NOTE: The adhesive dispensing gun is a non-reimbursable shop tool.

REPAIR PROCEDURE:

1. Raise and support the vehicle. Refer to the detailed service procedures available in DealerCONNECT> TechCONNECT under: Service Info> 04 - Vehicle Quick Reference> Hoisting> Standard Procedure.
2. Remove the front wheel assemblies. Refer to the detailed service procedures available in DealerCONNECT> TechCONNECT under: Service Info> 22 - Tires and Wheels> Removal and Installation.
3. Remove the upper fasteners (1) from the shock absorber (Fig. 2).
4. Remove the lower fasteners (2) from the shock absorber (Fig. 2).
5. Reposition the shock absorber (3) for access to the upper shock absorber bracket (Fig. 2).

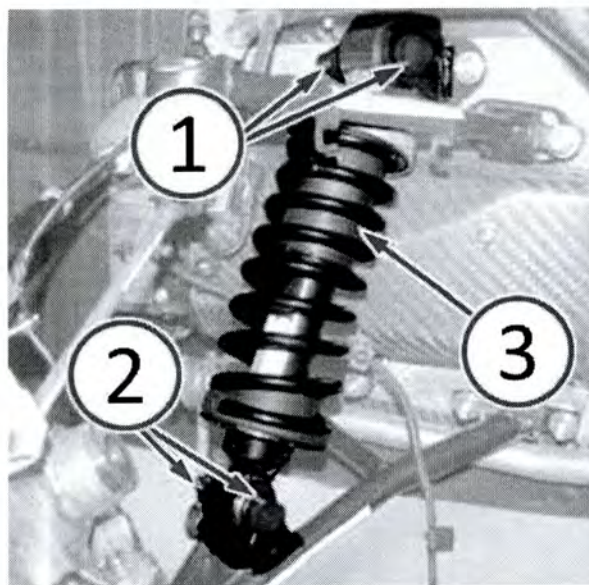

Fig. 2 Remove Fasteners And Reposition Shock Absorber

- 1 - Shock Absorber Upper Fasteners
- 2 - Shock Absorber Lower Fasteners
- 3 - Shock Absorber

-
- 6. Remove and discard the nuts (1) from the shock absorber bracket (Fig. 3).
 - 7. Remove and discard the bolt (2) from the shock absorber bracket (Fig. 3).
 - 8. Remove the shock absorber bracket (3) from the vehicle (Fig. 3).

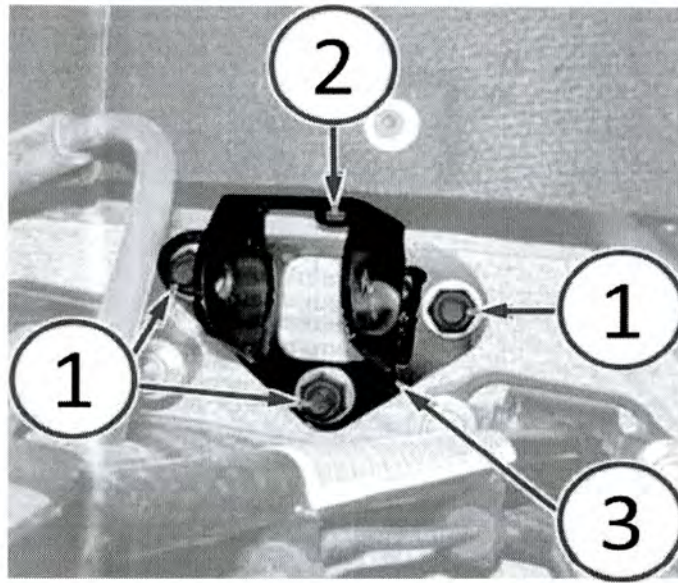

Fig. 3 Remove Shock Absorber Upper Bracket

- 1 - Shock Absorber Bracket Fastener Nuts
- 2 - Shock Absorber Bracket Fastener Bolt
- 3 - Shock Absorber Bracket

9. Using a clean cloth and isopropyl alcohol (1), thoroughly clean the shock absorber bracket top surface (2) (Fig. 4).

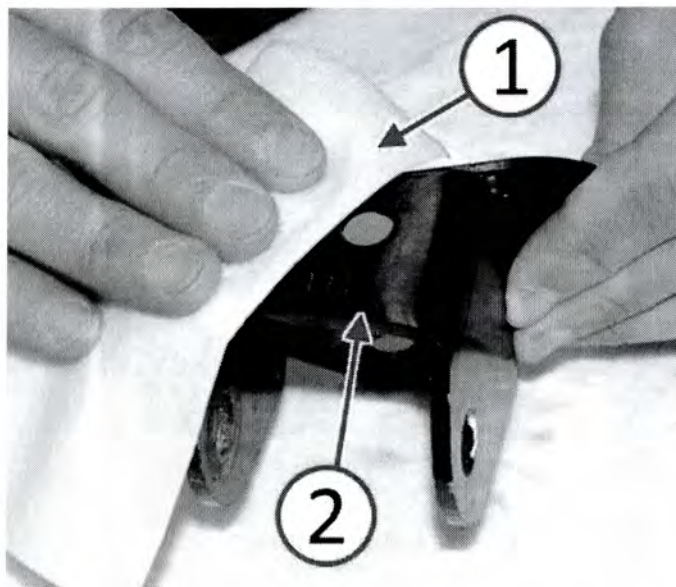

Fig. 4 Clean Shock Absorber Bracket Top Surface

- 1 - Alcohol Wipe
 - 2 - Shock Absorber Bracket Top Surface
-

10. Using a clean cloth and isopropyl alcohol (1), thoroughly clean the carbon fiber vehicle structure at the shock absorber bracket contact surface (Fig. 5).

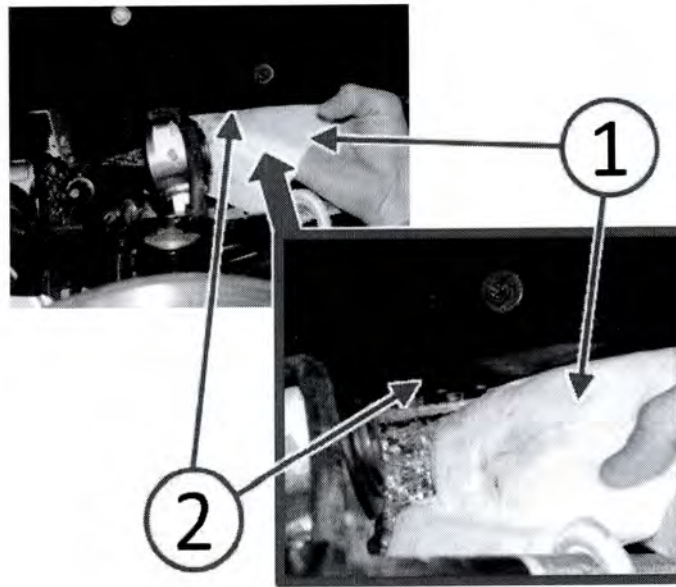

Fig. 5 Clean Contact Surface Of Structure To Shock Absorber Bracket

1 - Alcohol Wipe

2 - Carbon Fiber Structure Shock Absorber Bracket Contact Surface

-
11. Using an abrasive pad (1), scuff the top surface (2) of the shock absorber bracket to improve adhesive bond (Fig. 6).
 12. Using an abrasive pad, also scuff the carbon fiber vehicle structure at the bracket contact surface to improve adhesive bond.

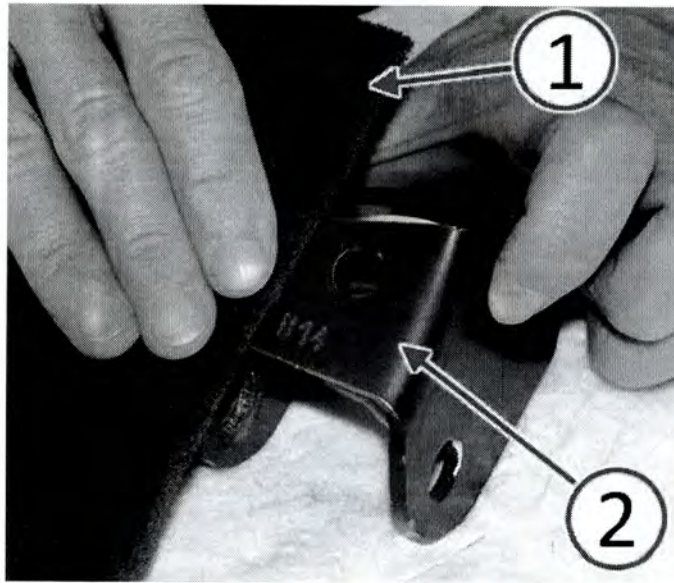

Fig. 6 Scuff Top Surface Of Shock Absorber Bracket With Abrasive Pad

- 1 - Abrasive Pad
 - 2 - Shock Absorber Bracket Top Surface
-

13. Insert the two-component structural adhesive cartridge into the dispensing gun.
14. Squeeze a small amount of the two-component adhesive from each side of the cartridge (1) (Fig. 7). This will level the plungers and ensure that the adhesive is coming out of both sides of the adhesive cartridge.

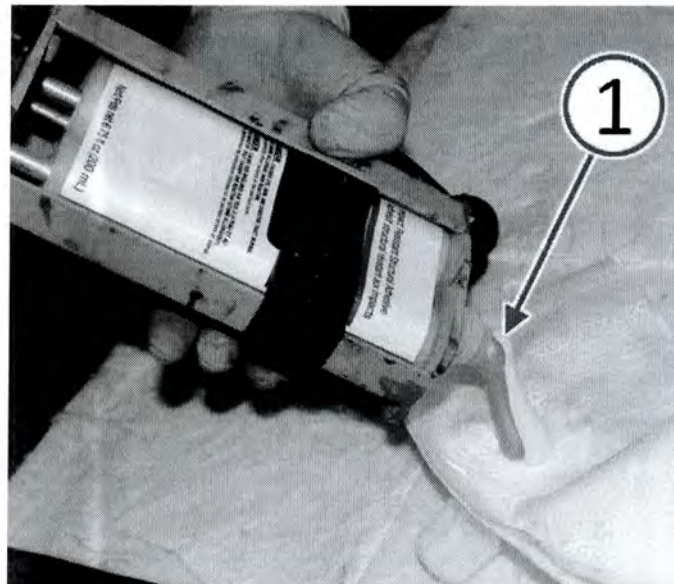

Fig. 7 Purge Air From Adhesive Cartridge

- 1 - Purge Air From Adhesive Cartridge
-

15. Attach the mixing tip (1) to the adhesive cartridge then dispense a small amount of material (2), approximately the length of the mixing tip, to verify that the adhesive is evenly mixed in the mixing tip (Fig. 8).

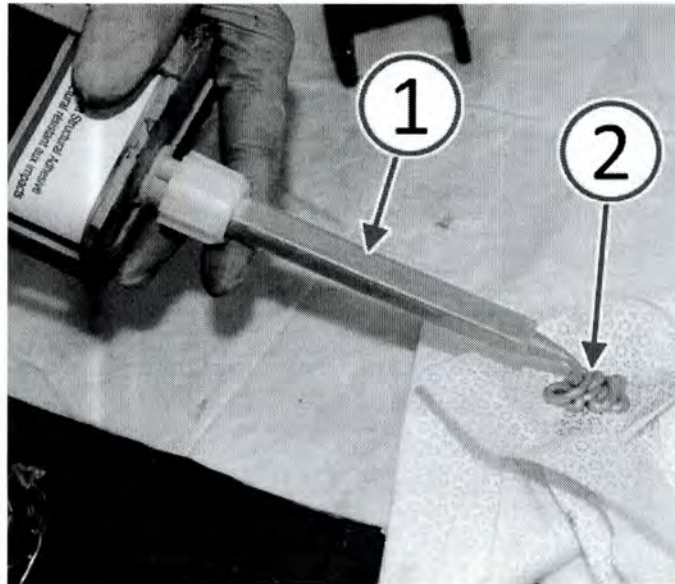

Fig. 8 Attach Mixing Tip To Adhesive Cartridge And Ensure Proper Mix

- 1 - Adhesive Cartridge Mixing Tip
 - 2 - Verify Even Two-Component Adhesive Mixing
-

NOTE: The structural adhesive (1) must not cover the fastener hole (2) (Fig. 9).

16. Apply structural adhesive (1) to the top surface of the shock absorber bracket. Be sure to avoid the fastener hole (2) (Fig. 9).

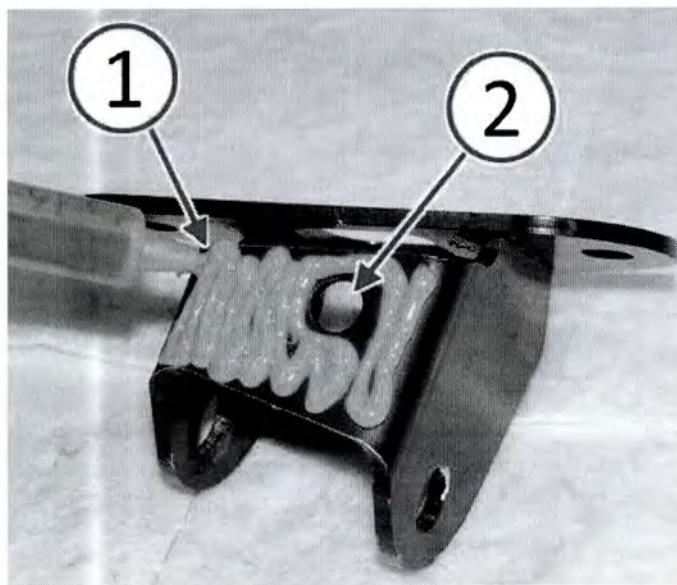

Fig. 9 Apply Adhesive to Shock Bracket Top Surface

- 1 - Apply Adhesive
- 2 - M8 Bolt Hole

-
- 17. Install the shock absorber bracket (1) to the vehicle structure (Fig. 10).
 - 18. Install by hand but do not fully tighten the **NEW** M10 nuts (2) (Fig. 10).
 - 19. Apply MOPAR lock & seal adhesive or equivalent to the **NEW** M8 bolt threads and install by hand but do not fully tighten the **NEW** M8 bolt (3) (Fig. 10).

NOTE: Ensure the shock absorber bracket is held firmly against the vehicle structure mounting surfaces (no gap visible) before tightening the fasteners.

- 20. Tighten the M10 nuts (2) to 55 N·m (41 ft. lbs.) + 45 degrees (Fig. 10).
- 21. Tighten the M8 bolt (3) to 20 N·m (15 ft. lbs.) (Fig. 10).

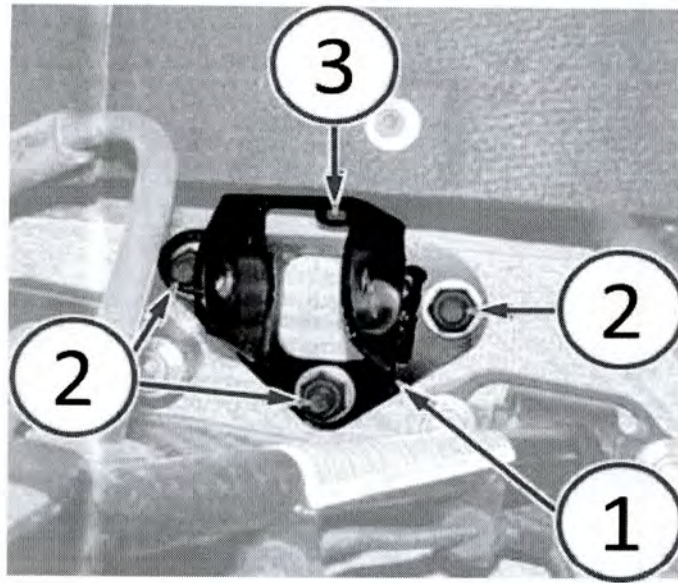

Fig. 10 Install Shock Absorber Bracket Using New Fasteners

- 1 - Shock Absorber Bracket
- 2 - Shock Absorber Bracket Fastener Nuts
- 3 - Shock Absorber Bracket Fastener Bolt

22. Remove any excess structural adhesive (1) that may have squeezed out between the shock absorber bracket and the vehicle structure (Fig. 11).

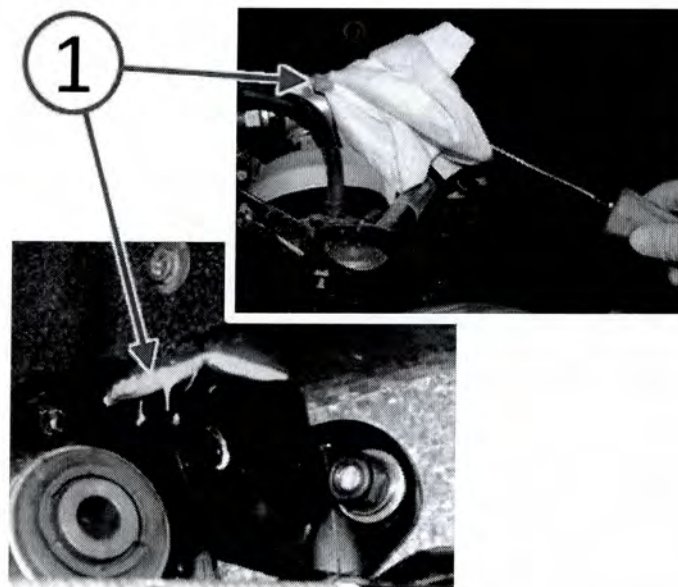

Fig. 11 Remove Excess Adhesive

- 1 - Excess Adhesive
-

23. Place the shock absorber (1) into the proper mounting position (Fig. 12).
24. Install by hand but do not fully tighten the **NEW** lower M12 shock absorber fasteners (2) (Fig. 12).
25. Install by hand but do not fully tighten the **NEW** upper M14 shock absorber fasteners (3) (Fig. 12).
26. Place the suspension at curb height before tightening the upper and lower shock absorber fasteners.
27. Tighten the lower M12 nut (2) to 120 N·m (89 ft. lbs.) (Fig. 12).
28. Tighten the upper M14 nut (3) to 150 N·m (110 ft. lbs.) (Fig. 12).

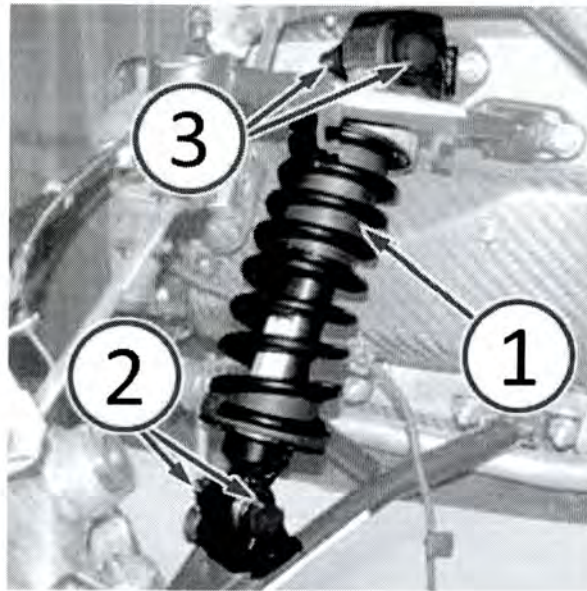

Fig. 12 Install Shock Absorber Using New Fasteners

- 1 - Shock Absorber
- 2 - Shock Absorber Lower Fasteners
- 3 - Shock Absorber Upper Fasteners

29. Install the front wheel assemblies. Refer to the detailed service procedures available in DealerCONNECT> TechCONNECT under: Service Info> 22 - Tires and Wheels> Removal and Installation.

CAUTION: The vehicle must be parked in an area where the ambient temperature is at or above 72 degrees F (22 degrees C) and structural adhesive must be allowed to cure for one hour before driving the vehicle on the road.

30. Lower the vehicle and park for 1 hour at 72 degrees F (22 degrees C) before driving.
31. Verify the popping noise has been eliminated.

POLICY:

Reimbursable within the provisions of the warranty.

TIME ALLOWANCE:

Labor Operation No:	Description	Skill Category	Amount
02-15-17-90	Bond Right And Left Front Upper Shock Absorber Brackets To Carbon Fiber Structure (1 - Semi-Skilled)	4 - Chassis Systems	1.5 Hrs.

FAILURE CODE:

ZZ	Service Action
----	----------------

PART REIMBURSEMENT DETAIL:

Part No:	Description
NPN	MOPAR Lock & Seal Adhesive
NPN	LORD Fusor® 2098 Structural Adhesive = 6.59 oz (195 mL) OR 3M® 07333 Structural Adhesive = 6.75 oz (200 mL)

NOTE: This part number is for reimbursement only and will need to be claimed for 1/6 of Dealer Net of Part No. 04318031 or it will be rejected.

NOTE: This part number is for reimbursement only and will need to be claimed for the value of LORD Fusor® 2098 or 3M® 07333 or it will be rejected. If this is a non-MOPAR part or product, a copy of the invoice showing the purchase of the non-MOPAR part or product needs to be attached to the reimbursement claim.