



## Reroute Power Steering Harness

<b>Classification</b>	Campaign Bulletin	<b>Section/Group</b>	17 - Electrical	<b>Country/Region</b>	United States, Canada
<b>Year</b>	2014-2015	<b>Model</b>	Model S	<b>Version</b>	Dual Motor

**Bulletin Classification:** *This campaign bulletin addresses a known non-safety-related condition and provides recommended technical diagnosis and repair procedures. Apply this procedure to all vehicles in the affected VIN range listed. These instructions assume knowledge of motor vehicle and high voltage electrical component repairs, and should only be executed by trained professionals. Tesla Motors assumes no liability for injury or property damage due to a failure to properly follow these instructions or repairs attempted by unqualified individuals.*

### Condition

On some vehicles, the LH halfshaft might contact the power steering harness. This might result in an alert message on the instrument cluster.

### Correction

If necessary, reroute or replace the power steering harness.

Required Part(s):	Part Number	Description	Quantity
	1015140-00-A	M5 CABLE TIE CLIP	2
	1018783-00-B	CABLE TIE,50LB,11.8,PA66,BLACK	1 (If required)

These part numbers were current at the time of publication. Use the revisions listed or later, unless otherwise specified in the Parts Manual.

Correction Description	Correction	Time
SB-15-17-001 Not Applicable	S011517001	0.00
Vehicle Inspection Only; Rerouting Power Steering Harness And Installing Cable Tie Not Required	S021517001	0.10
Reroute Power Steering Harness And Install Cable Tie	S031517001	0.15

## Inspect Power Steering Harness Routing

1. Remove the underhood storage unit (refer to Service Manual procedure 15245002).
2. Near the LH front halfshaft, inspect the routing of the power steering harness relative to the coolant hose that connects to the RH side of the 4-way valve:

**NOTE:** The RH hose curves back towards the LH side of the vehicle.

- If the power steering harness routes in front of or next to the hose (Figure 1), skip to the “Inspect Clips and Ties” section of this document.
- If the power steering harness routes behind the hose (Figure 2), continue this procedure to reroute it.

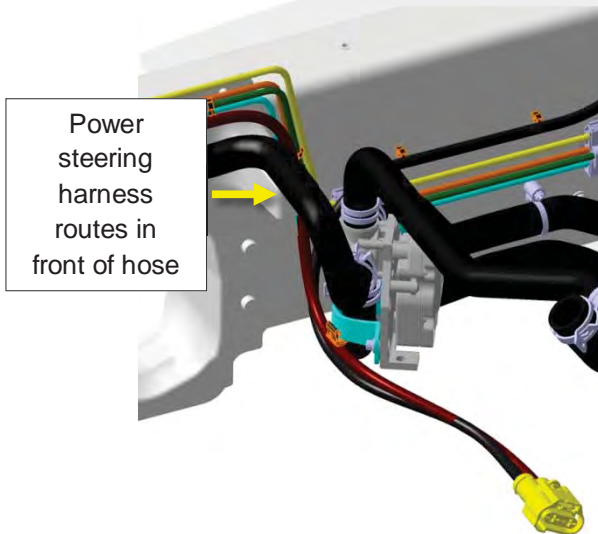

✓ Figure 1

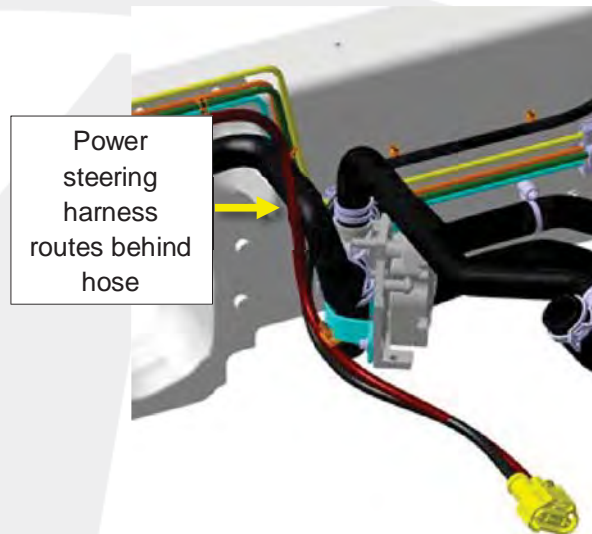

✗ Figure 2

3. If the harness is secured to the 4 way valve with a cable tie, remove the cable tie.
4. Disconnect the power steering harness from the steering rack.

5. Release the nut that secures the power steering harness negative wire to the LH side rail (torque 9 Nm) (Figure 3).

**⚠ CAUTION:** During reinstallation, torque this nut slowly to avoid breaking the stud off the body.

**NOTE:** This nut also secures negative terminals of other wires. Note the order in which the terminals are removed.



**Figure 3**

6. Gently pull the free end of the power steering harness out from behind the coolant hose (Figure 4).

**NOTE:** An edge clip secures the power steering harness to either the 4-way valve or the bracket behind the 4-way valve. Do not damage the edge clip during removal.

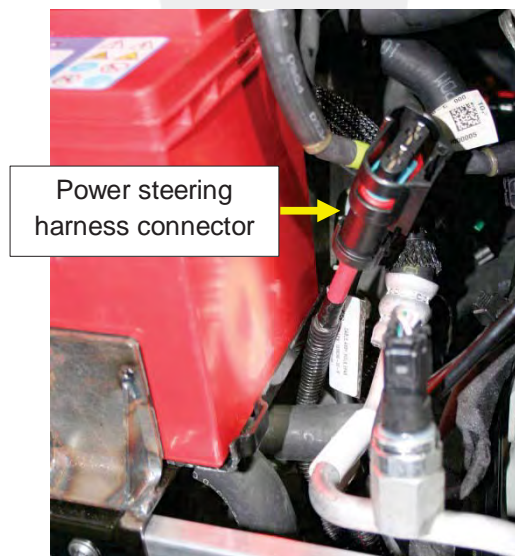

**Figure 4**

**⚠ CAUTION:** Carefully inspect the power steering harness for damage. If any damage is present, the harness must be replaced. Discontinue this procedure and contact Service Engineering.

7. Route the power steering harness in front of the coolant hose and behind the 4-way valve (Figure 5).

**⚠ CAUTION:** Ensure that the harness does not touch the 4-way valve, bracket, or hoses.

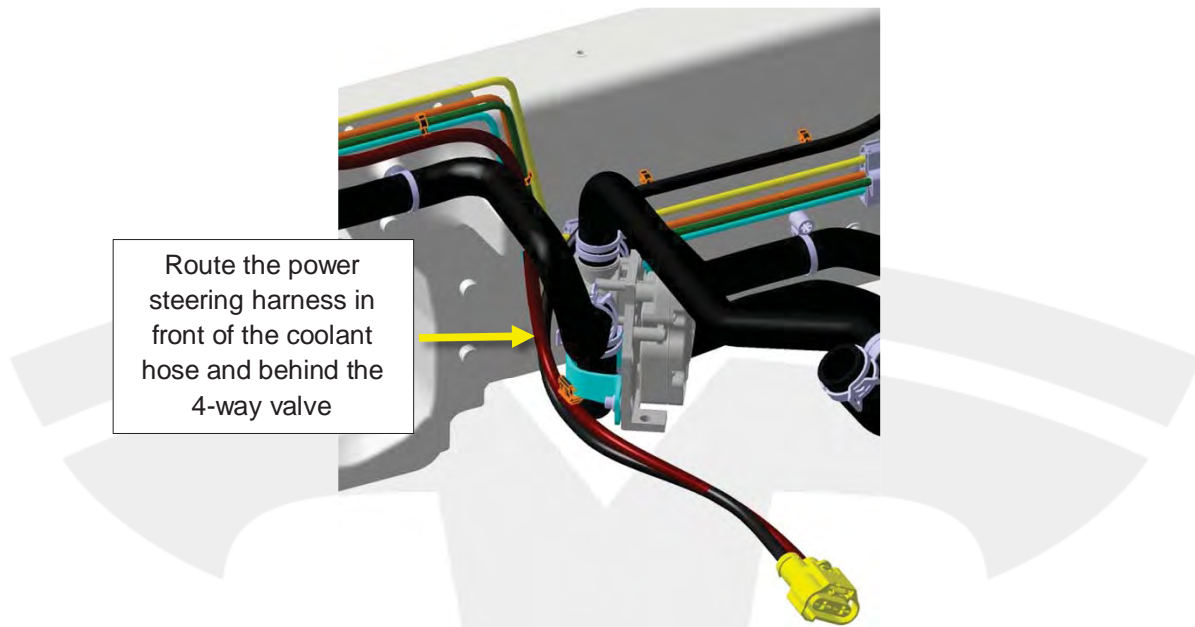

Figure 5

8. Reconnect the power steering harness to the steering rack.

## Inspect Clips and Ties

1. Ensure that the 2 clips on the power steering harness are secured to the brake line, as shown (Figure 6).

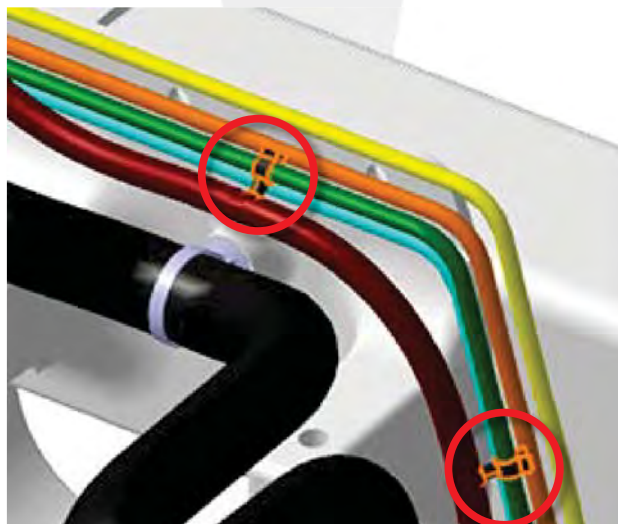
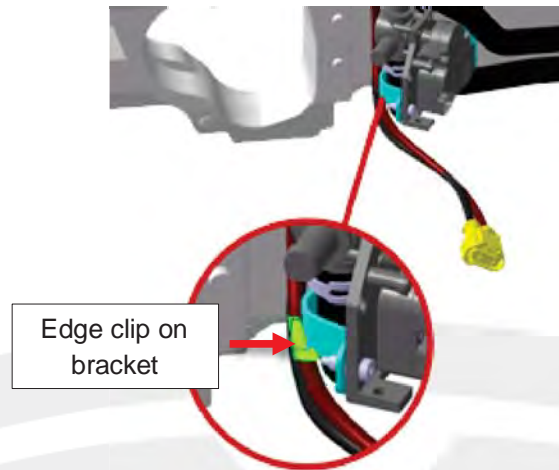

Figure 6

2. Ensure that the edge clip on the power steering harness is secured to the 4-way valve bracket (Figure 7).



**Figure 7**

3. Reinstall the negative terminals to the LH side rail ground stud.
4. Inspect the hole on the RH side of the 4-way valve (Figure 8); if a cable tie is installed, remove it.

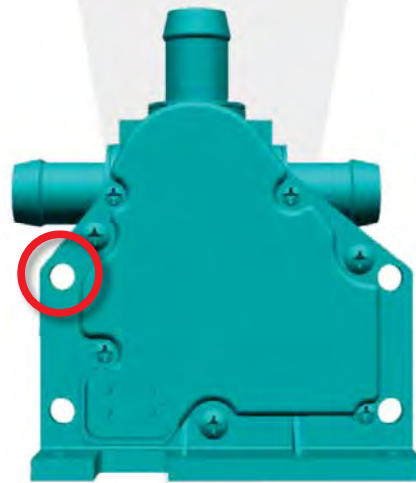

**Figure 8**

5. Use a cable tie to secure the positive and negative wires of the power steering harness together between the 2 white labels, approximately 8 in (203 mm) from the steering rack. Remove any excess tie.
6. Reinstall all components that were removed for access.

**⚠ CAUTION:** When reinstalling the power steering negative wire to the LH side rail, torque the nut slowly to avoid breaking the stud off the body.

---

**Affected VIN(s)** Some Dual Motor Model S vehicles built between approximately September 18, 2014 and January 30, 2015.

**NOTE:** This is a simplified summary of the affected VIN list. Refer to the VIN/Bulletin Tracker or Customer/Vehicle profile to determine applicability of this bulletin for a particular vehicle.

For feedback on the accuracy of this document, email [ServiceBulletinFeedback@teslamotors.com](mailto:ServiceBulletinFeedback@teslamotors.com).





# Reroute Power Steering Harness

<b>Classification</b>	Campaign Bulletin	<b>Section/Group</b>	17 - Electrical	<b>Country/Region</b>	United States, Canada
<b>Year</b>	2014-2015	<b>Model</b>	Model S	<b>Version</b>	Dual Motor

**Bulletin Classification:** *This campaign bulletin addresses a known non-safety-related condition and provides recommended technical diagnosis and repair procedures. Apply this procedure to all vehicles in the affected VIN range listed. These instructions assume knowledge of motor vehicle and high voltage electrical component repairs, and should only be executed by trained professionals. Tesla Motors assumes no liability for injury or property damage due to a failure to properly follow these instructions or repairs attempted by unqualified individuals.*

*This Service Bulletin supersedes SB-15-17-001, dated 5-Feb-14. Each content change is marked by a vertical line in the left margin. Discard the previous version and replace it with this one.*

## Condition

On some vehicles, the LH halfshaft might contact the power steering harness. This might result in an alert message on the instrument cluster.

## Correction

If necessary, reroute or replace the power steering harness.

Required Part(s):	Part Number	Description	Quantity
	1015140-00-A	M5 CABLE TIE CLIP	2
	1018783-00-B	CABLE TIE,50LB,11.8,PA66,BLACK	1 (If required)

These part numbers were current at the time of publication. Use the revisions listed or later, unless otherwise specified in the Parts Manual.

Correction Description	Correction	Time
(Obsolete code; do not use)	S011517001	0.00
Vehicle Inspection Only; Rerouting Power Steering Harness And Installing Cable Tie Not Required	S021517001	0.10
Reroute Power Steering Harness And Install Cable Tie	S031517001	0.15

## Inspect Power Steering Harness Routing

1. Remove the underhood storage unit (refer to Service Manual procedure 15242002).
2. Near the LH front halfshaft, inspect the routing of the power steering harness relative to the coolant hose that connects to the RH side of the 4-way valve:

**NOTE:** The RH hose curves back towards the LH side of the vehicle.

- If the power steering harness routes in front of or next to the hose (Figure 1), skip to the “Inspect Clips and Ties” section of this document.
- If the power steering harness routes behind the hose (Figure 2), continue this procedure to reroute it.

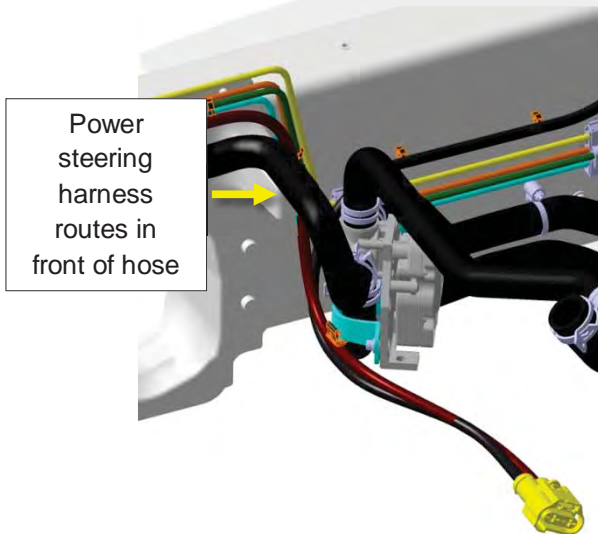

✓ Figure 1

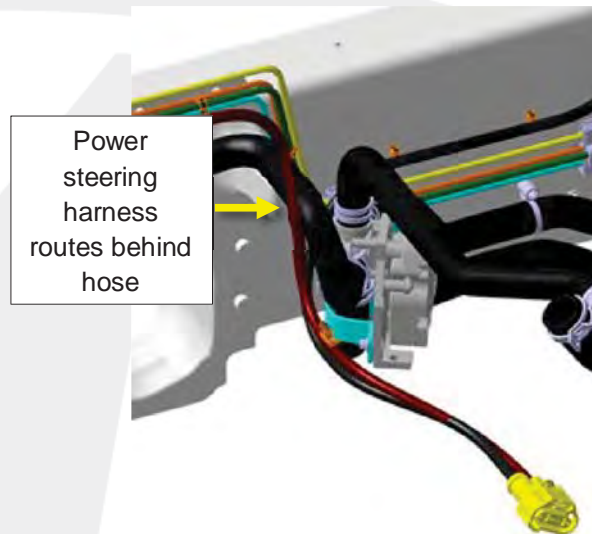

✗ Figure 2

3. If the harness is secured to the 4 way valve with a cable tie, remove the cable tie.
4. Disconnect the power steering harness from the steering rack.

5. Release the nut that secures the power steering harness negative wire to the LH side rail (torque 9 Nm) (Figure 3).

**⚠ CAUTION:** During reinstallation, torque this nut slowly to avoid breaking the stud off the body.

**NOTE:** This nut also secures negative terminals of other wires. Note the order in which the terminals are removed.



**Figure 3**

6. Gently pull the free end of the power steering harness out from behind the coolant hose (Figure 4).

**NOTE:** An edge clip secures the power steering harness to either the 4-way valve or the bracket behind the 4-way valve. Do not damage the edge clip during removal.

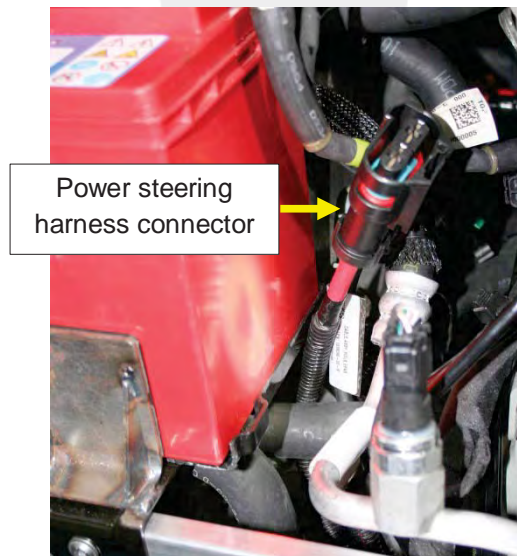

**Figure 4**

**⚠ CAUTION:** Carefully inspect the power steering harness for damage. If any damage is present, the harness must be replaced. Discontinue this procedure and contact Service Engineering.

7. Route the power steering harness in front of the coolant hose and behind the 4-way valve (Figure 5).

**⚠ CAUTION:** Ensure that the harness does not touch the 4-way valve, bracket, or hoses.

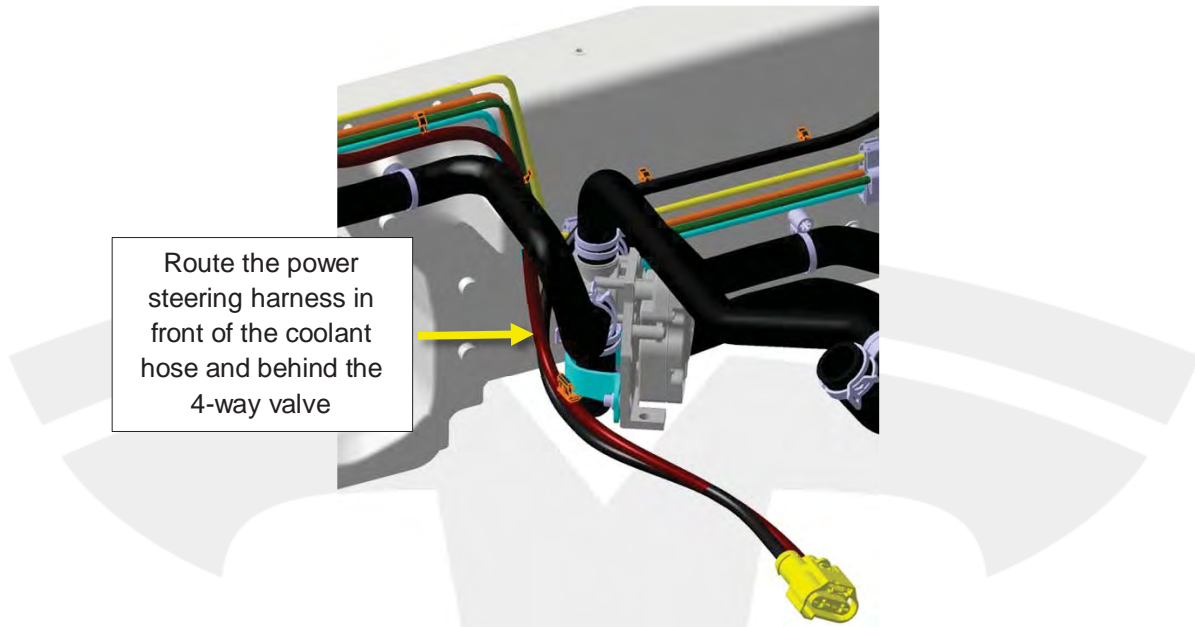

Figure 5

8. Reconnect the power steering harness to the steering rack.

## Inspect Clips and Ties

1. Ensure that the 2 clips on the power steering harness are secured to the brake line, as shown (Figure 6).

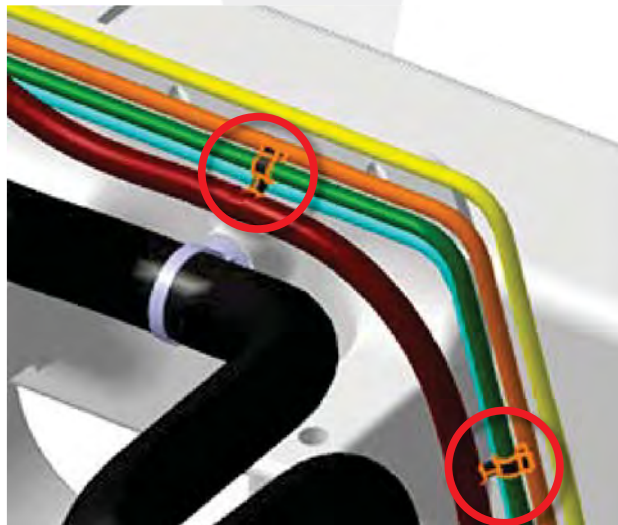
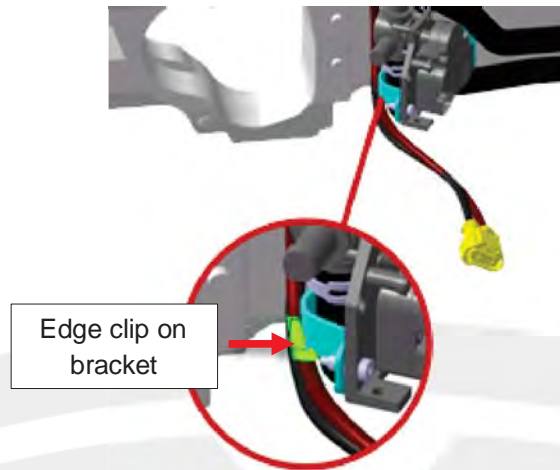

Figure 6

2. Ensure that the edge clip on the power steering harness is secured to the 4-way valve bracket (Figure 7).



**Figure 7**

3. Reinstall the negative terminals to the LH side rail ground stud.
4. Inspect the hole on the RH side of the 4-way valve (Figure 8); if a cable tie is installed, remove it.

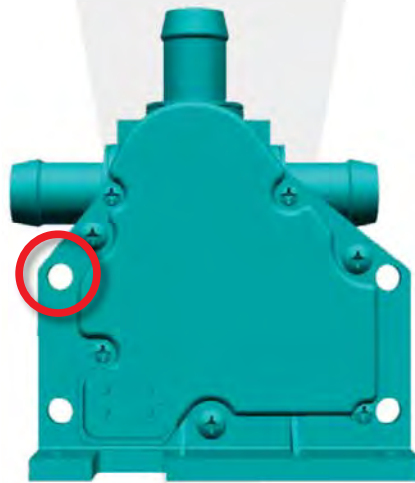

**Figure 8**

5. Use a cable tie to secure the positive and negative wires of the power steering harness together between the 2 white labels, approximately 8 in (203 mm) from the steering rack. Remove any excess tie.
6. Reinstall all components that were removed for access.

**⚠ CAUTION:** When reinstalling the power steering negative wire to the LH side rail, torque the nut slowly to avoid breaking the stud off the body.

---

**Affected VIN(s)** Some Dual Motor Model S vehicles built between approximately September 18, 2014 and January 30, 2015.

**NOTE:** This is a simplified summary of the affected VIN list. Refer to the VIN/Bulletin Tracker or Customer/Vehicle profile to determine applicability of this bulletin for a particular vehicle.

For feedback on the accuracy of this document, email [ServiceBulletinFeedback@teslamotors.com](mailto:ServiceBulletinFeedback@teslamotors.com).

