

# **SB-10057787-1777**

## **\* \* TECHNICAL INFORMATION NOTICE \* \***

**DATE:** April 24, 2015  
**TO:** Mitsubishi Motors US Dealer Service Managers  
**RE:** Stumble on Acceleration  
**TIN NO.** TIN-15-23-001

.....

**AFFECTED VEHICLES:** 2015 Outlander Sport Equipped with 2.0L Engine and F1CJC or W1CJC CVT Automatic Transaxle

### **PURPOSE**

MMNA is investigating an intermittent condition where during acceleration; customers may report a momentary stumble or lack of acceleration at low speeds.

If contacted by a customer experiencing this condition, please inspect the "Transmission Range Switch and Control Cable Adjustment" on the vehicle. Instructions for this adjustment can be found in the attached illustration.

Test drive the vehicle to confirm the condition no longer exists. If the condition is not resolved with this procedure, please contact Techline.

## TRANSMISSION RANGE SWITCH AND CONTROL CABLE ADJUSTMENT

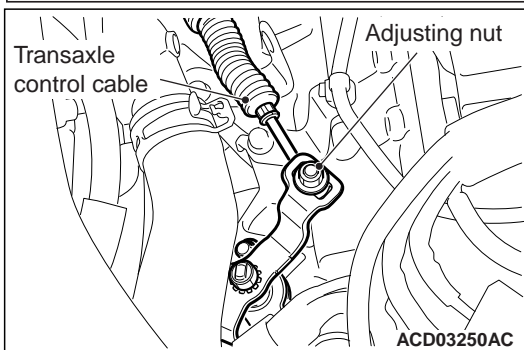
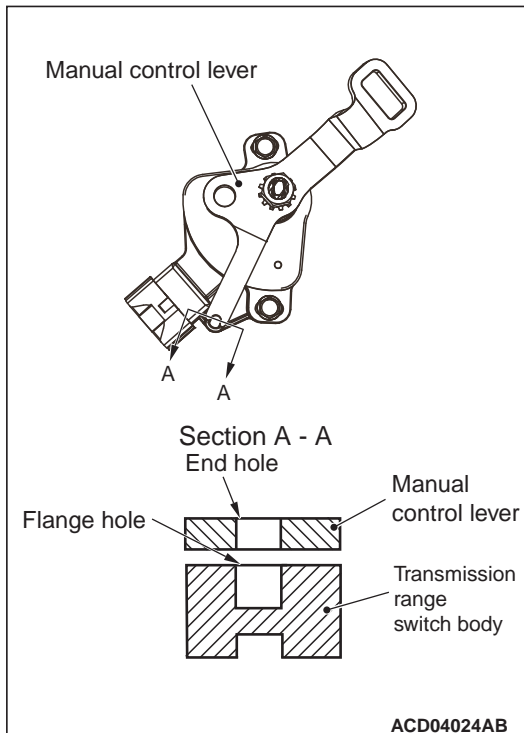
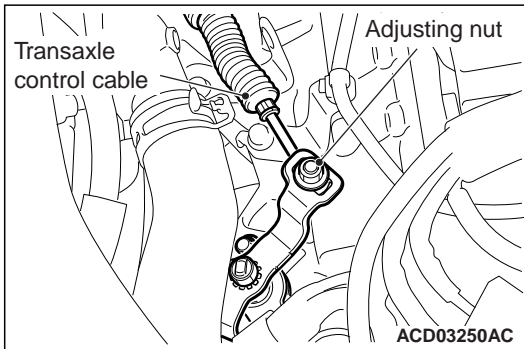

1. Move the selector lever to the "N" range.
2. Loosen the adjusting nut so that the manual control lever moves freely.
3. Move the manual control lever to neutral position.
4. Align the hole at the end of the manual control lever and the hole in the transmission range switch body flange (section A - A).
5. Use the adjusting nut to tighten the transaxle control cable to the specified torque.  
**Tightening torque:  $9.5 \pm 3.5$  N·m ( $84 \pm 30$  in-lb)**
6. Make sure that the selector lever is in the "N" range.
7. Make sure that the transaxle ranges that are corresponding to the selector lever position operate and function properly.