

SERVICE BULLETIN



M-1401

SB-10057784-1093 April 13, 2015

PRODUCT PROGRAM 0919: 2015 STREET MODELS RIGHT SIDE RIDER FOOT CONTROL MOUNTING SCREWS

Purpose

Harley-Davidson Motor Company, Inc. has declared a voluntary Product Program (0919), offering a no-charge repair of the installation torque for the right side rider foot control mounting screws on affected motorcycles for this non-safety issue.

Read this entire bulletin before taking any action. See Required Dealer Action to perform the service.

Overview

- **Kits required:** No.
- **Repair:** All affected. No inspection required.
- **Affected components:** Right side rider foot control mounting screws.
- **Solution:** Loosen and retighten screws to proper torque specification.

Motorcycles Affected

This product program applies to certain 2015 Street XG500 and XG750 motorcycles.

A VIN list specific to motorcycles shipped to your dealership is available via h-dnet.com. This list may be found by following this path:

- h-dnet.com/Service Toolbox/Program Campaign Open VIN List

Select 0919 campaign to view the VIN list.

NOTE

If the motorcycle does not appear on your dealer VIN list, refer to the Vehicle Information link to determine if the motorcycle is affected.

If you are not sure that this campaign has been completed on a particular motorcycle, check the campaign records available on TALON and h-dnet.com. Some dealers may not have any affected motorcycles.

Canadian Dealers: To determine if this campaign has been completed on a particular motorcycle, use the h-dnet.com vehicle information link found on the service tab of UltraComm.

Markets Affected

North America (U.S. and Canada) are the only markets affected.

Customer Notification

Harley-Davidson Motor Company, Inc. will provide notification of this non-safety related condition to registered owners of affected motorcycles. The notice will instruct owners to contact their dealer to schedule the service. A sample of the customer letter is attached.

Canadian Retailers: Deeley Harley-Davidson Canada will send a letter to registered owners of affected motorcycles in Canada.

Program Duration

This program is effective beginning April 13, 2015. Be advised that the services delivered under this product program will no longer be rendered at factory expense after April 13, 2017 (two years from the date of this bulletin).

NOTE

In the interest of preserving customer safety and satisfaction, always check for outstanding recalls whenever any motorcycle is brought into your dealership for either maintenance or service.

ROUTING	SERVICE MANAGER	SALES MANAGER	PARTS MANAGER	WARRANTY PROCESS MANAGER	LEAD TECHNICIAN	TECHNICIAN NO. 1	TECHNICIAN NO. 2	TECHNICIAN NO. 3	RETURN THIS TO
INITIAL HERE									

© 2015 H-D

Required Dealer Action

1. Verify that motorcycle is involved in product program.

2. See Figure 1. Loosen both right side rider foot control mounting screws (3).

3. Retighten screws to 22.0-29.0 Nm (17-21 ft-lbs).

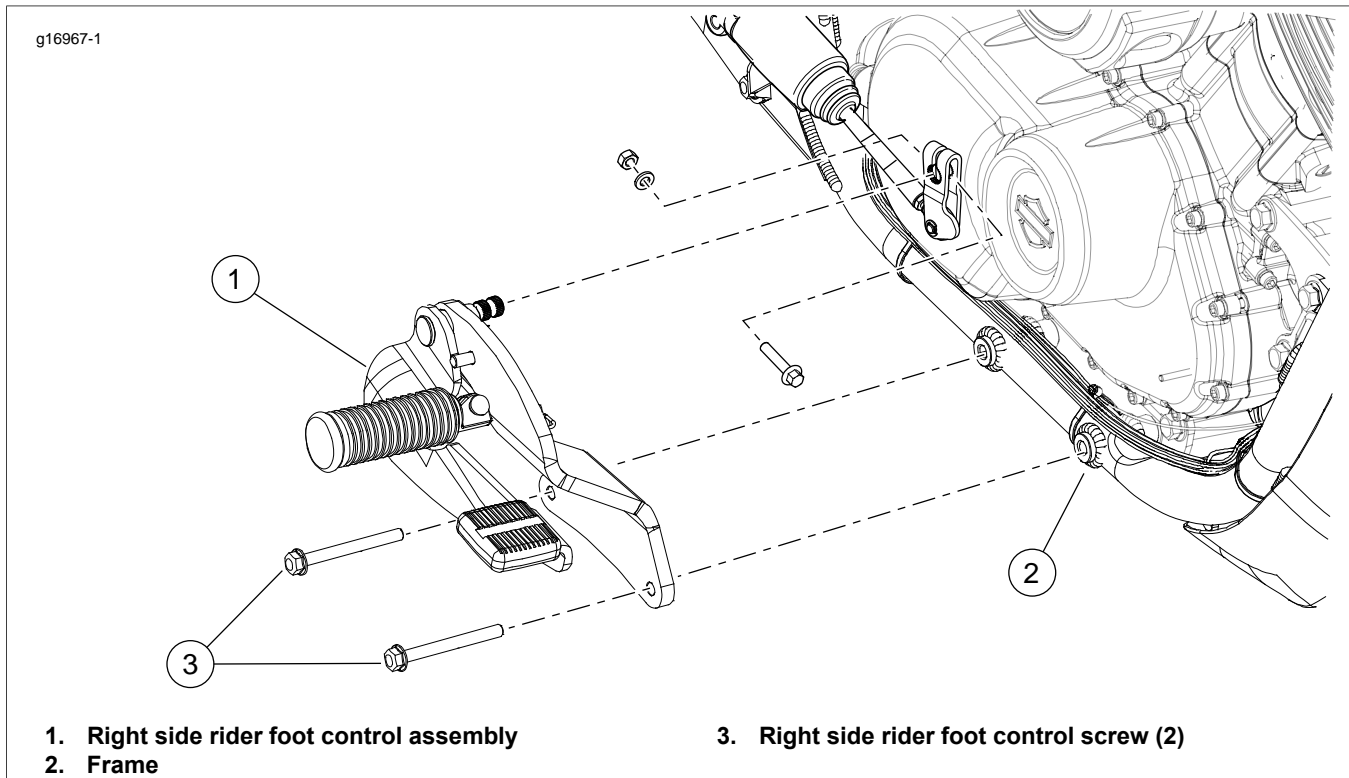

Figure 1. Right Side Rider Foot Control Assembly

Credit Procedure: VIN Involved in Campaign

Talon/h-dnet.com/UltraComm Warranty Claim Users

For each vehicle involved and repaired, submit an electronic campaign claim per the table below.

Table 1. Product Program 0919: Vehicle Involved/VIN Required

ITEM	DATA
Claim Type	PPC
Problem Part Number	10200055
Quantity	Leave Blank
Quantity (UltraComm users)	0
Primary Labor Code*	2685
Labor Time	0.1
Customer Concern Code*	0919
Condition Code	9981

* These items may need to be downloaded to your system.

Upon submitting the properly completed product campaign claim, you will be credited for 0.1 hours of labor time for performing the procedure. Submit campaign events on their own warranty claim. Do not mix them with other warranty events.

April 13, 2015

Dear Harley-Davidson Motorcycle Owner:

Our records indicate you are the owner of a 2015 XG model motorcycle. Harley-Davidson has recently discovered that the rider right foot control mounting bolts on some model year 2015 XG model motorcycles may have been assembled with an improper torque.

In the interest of customer satisfaction, Harley-Davidson is offering a no cost inspection and correction service (**Product Program 0919**) to the owners of affected 2015 XG model motorcycles.

While this is not a safety issue, we urge you to contact your authorized Harley-Davidson dealer to schedule an appointment to have the product inspection service performed. The service will be performed at no cost to you if performed within two years from the program announcement date. The service will require less than one-half hour to perform, however, due to scheduling, your dealer may request to have your motorcycle for a longer period of time.

This no cost offer expires two years from the date of the program announcement (April 13, 2017).

To verify that the service has been completed, your dealer will ask you to sign an acknowledgement when you pick up your motorcycle.

We thank you for your cooperation. We regret any inconvenience this may cause, but we have taken this action in the interest of your continued satisfaction with our product.

Sincerely,

Harley-Davidson Motor Company