



## INSTRUCTION TO SERVICE

ITS: 5909	
SECTION:	231 Coolant System
WRITTEN BY:	Mike Pearson
SUBJECT:	Add EMP Radiator Ground Straps

# ITS5909

THIS DOCUMENT AND THE CONTENTS DISCUSSED HEREIN ARE THE CONFIDENTIAL AND PROPRIETARY INFORMATION OF NEW FLYER INDUSTRIES CANADA ULC AND NEW FLYER OF AMERICA INC. AND ARE DISCLOSED BY NEW FLYER IN CONFIDENCE. THIS DOCUMENT AND THE CONTENTS HEREIN ARE NOT TO BE DISCLOSED BY THE INTENDED RECIPIENT WITHOUT THE PRIOR WRITTEN AUTHORIZATION OF NEW FLYER. ANY UNAUTHOIZED DISCLOSURE, REPRODUCTION OR OTHER DISTRIBUTION OF THIS DOCUMENT OR INFORMATION IS STRICTLY PROHIBITED AND MAY RESULT IN ACTION BEING TAKEN AGAINST THE PARTY MAKING THE UNAUTHORIZED DISCLOSURE. THIS DOCUMENT AND ALL COPIES HEREOF MUST BE RETURNED TO NEW FLYER UPON REQUEST.



**NEW FLYER**

## Bulletin Overview

If dissimilar metals have different electrode potentials, and come into contact with an electrolyte, one metal acts as an anode and the other as cathode. The electro potential difference between the dissimilar metals and the presence of electrolytic (salt) solutions can be the driving force for an accelerated attack on the anode member of the galvanic couple. The anode metal dissolves into the electrolyte, and deposits collect on the cathodic metal.

In normal service, voltage levels on coolant pipes have been found to be highly variable and can range anywhere from roughly -1V to +1V.

These voltage levels are capable of causing highly-accelerated heat exchanger corrosion.

Voltage potential between radiator and coolant pipes can be eliminated by grounding the Mini-Hybrid® cooling system and coolant pipes to the vehicle chassis.

**Note: If experiencing accelerated radiator corrosion, the work described in this bulletin must be completed in order to maintain your 3 year EMP radiator warranty coverage. Failure to act promptly may affect coverage for accelerated corrosion through the radiator due to stray current.**

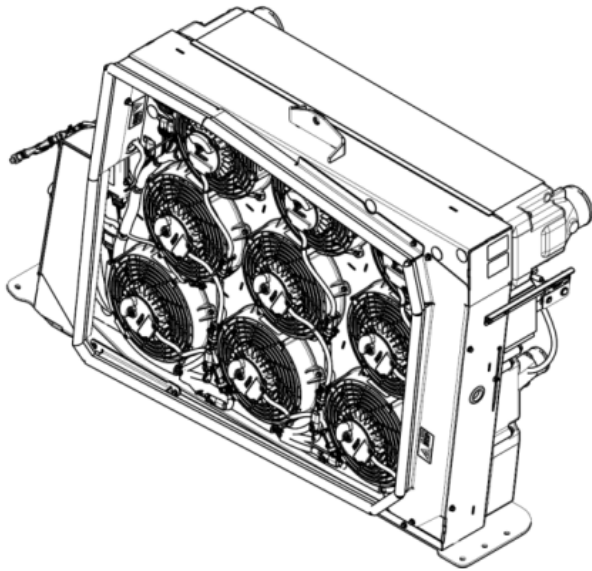

2020056000, 2020056032 and 2020070000

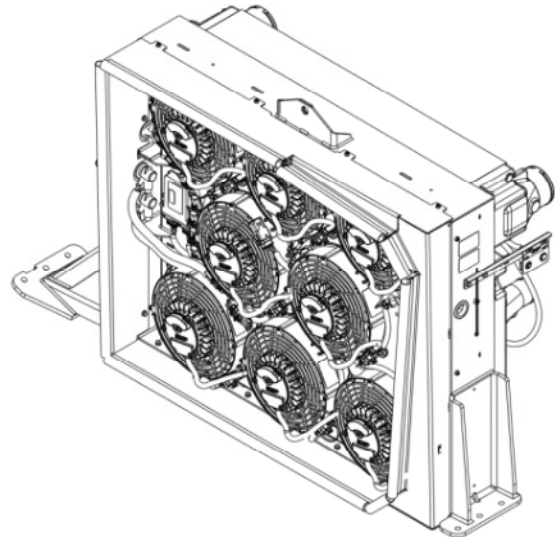

2020069000

Figure 1: Mini-Hybrid® Cooling Systems

## Issue

Radiator corrosion has been identified on buses with isolated pipe clamps on vehicles 2010 EPA or newer engines and Mini-Hybrid® cooling systems including:

Description	New Flyer p/n	EMP Base #
XCELSIOR HYBRID	451212	2020056000
XCELSIOR HYBRID	471779	2020056000P0001
XCELSIOR HYBRID ECOAT	554515	2020056032
MH8 NFI XPL1	507910	2020069000
MH8 XPL2	530993	2020070000PA01



**NEW FLYER**

Accelerated corrosion was located by the radiator outlet and was limited to vehicles running in icy or snowy winter locations. This corrosion has been determined to be caused by stray voltage carried by the coolant. If the pipes are separated from the radiator via silicone (non-conducting) hoses and the pipes and radiator are not on the same ground plane, electrolysis can occur between the pipes and the radiator. Grounding the radiator and pipes to the vehicle chassis eliminates the electrical potential, stopping the electrolytic corrosion. See Figure 2 for images of accelerated corrosion.



**Figure 2: Gen III Examples.**

**PROCEDURE:**

1. Turn the main battery disconnect switch to the "OFF" position.
2. Raise coach in accordance with the New Flyer Service Manual.
3. Typical coolant tube clamp ground strap mounting hardware orientation, see Figure 3.



**Figure 3: Ground Strap Mounting Hardware Orientation**



## NEW FLYER

4. To ground Mini-Hybrid® cooling system shroud, back off the 1/4-20 screw holding the reverse pushbutton bracket enough to insert provided hook terminal from 50" cable. Insert the terminal between the flange head and the bracket. There is no need to scrape any powder off the Mini-Hybrid® system shroud as a good ground is achieved through the PEM nut in the shroud. Torque to  $12 \pm 2$  ft-lbs.
5. Route ground wire to area approximately 4.5" forward of the welded rail (see Figure 7), routing wire away from any hot surfaces or sharp edges. Use zip ties to secure wire at 18-24" intervals. Adjust cable orientation if necessary. Proceed with grounding of radiator tubes before securing shroud ground wire.

**CAUTION: Grounding to the same welded assembly is required. Grounding to a bolted assembly is NOT acceptable.**

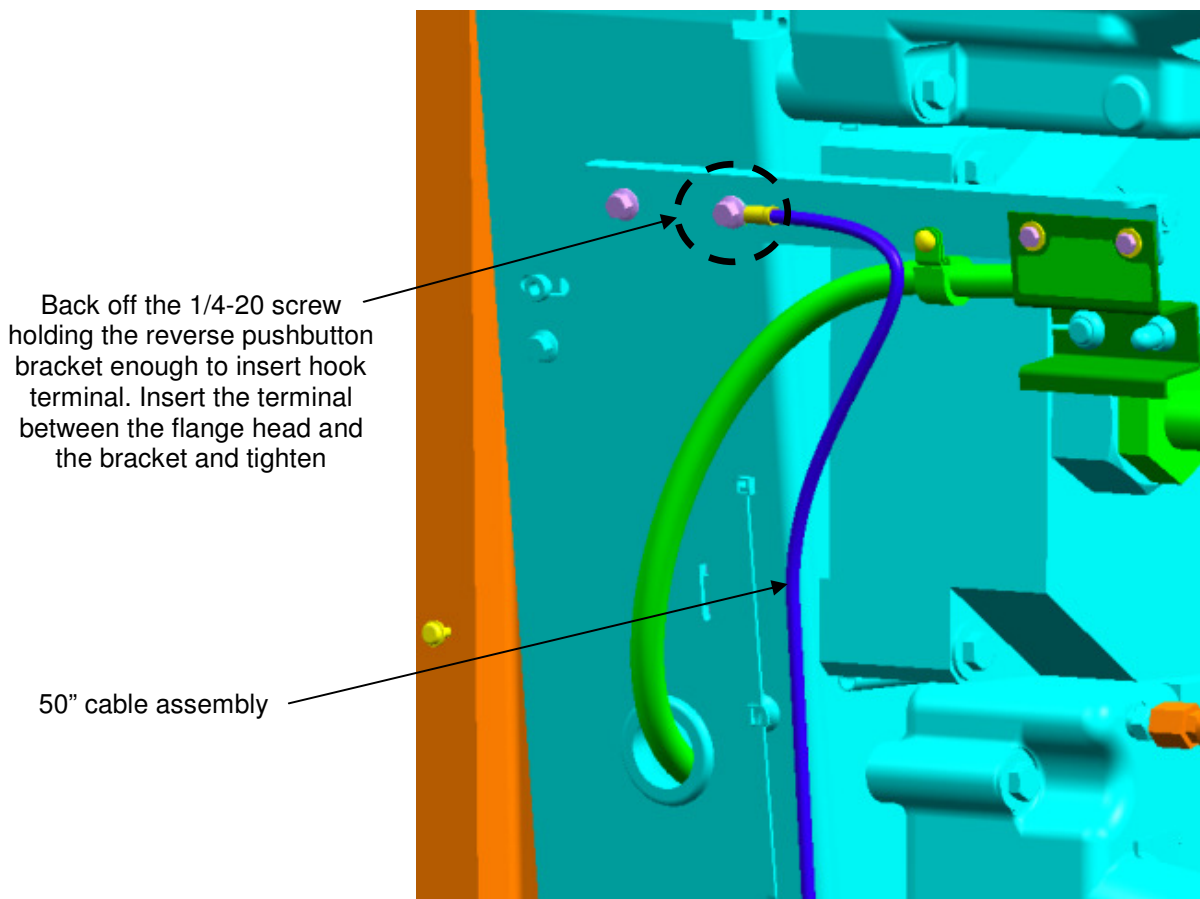
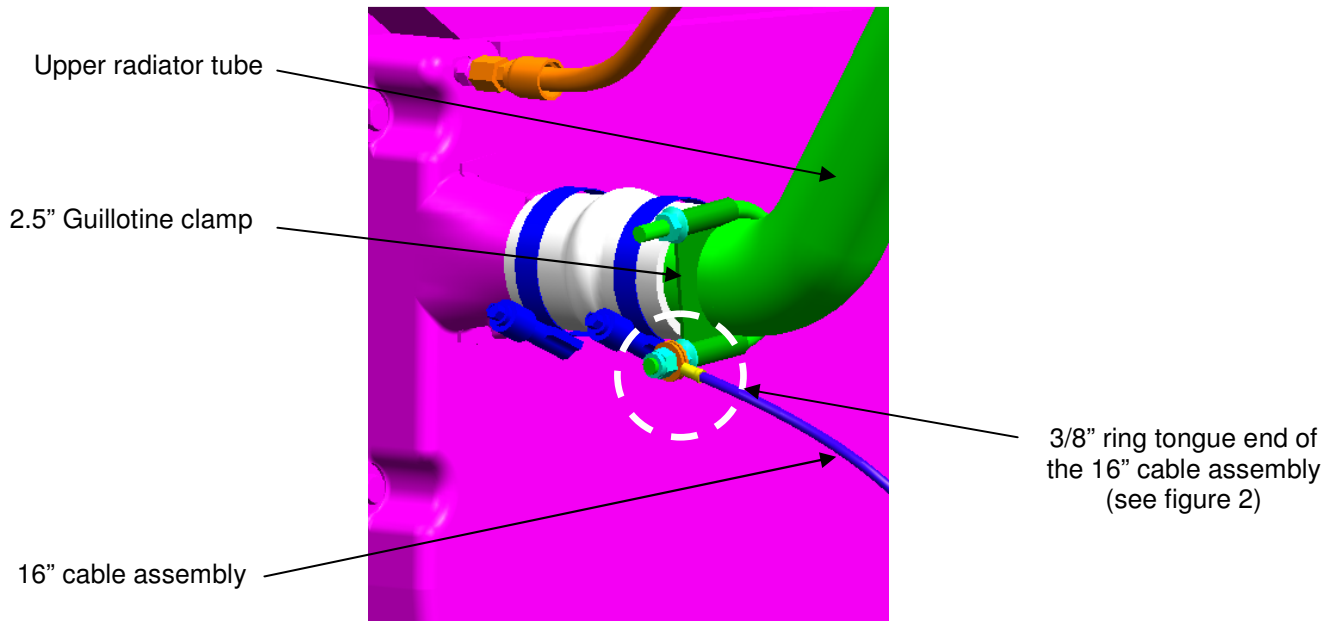

**Figure 4: Existing Rear Corner Support Angle**

6. Install one of the 2.5" guillotine clamps from the parts kit to the existing upper radiator tube at the approximate location and orientation shown in Figure 5, torque to  $20 \pm 2$  ft\*lbs.
7. Attach the 3/8" ring tongue end of the 16" cable to the bottom stud of the guillotine clamp. Secure and orient the hardware as shown in Figure 3. Torque the hardware to  $20 \pm 2$  ft\*lbs.
8. Route ground wire to area approximately 4.5" forward of the welded rail (see Figure 7), routing wire away from any hot surfaces or sharp edges. Adjust clamp locations on coolant pipes if necessary.



**NEW FLYER**



**Figure 5: Radiator and Upper Coolant Tube Ground Strap Installation**

9. Install one of the 2.5" guillotine clamps from the parts kit to the existing lower radiator tube at the approximate location and orientation shown in Figure 6, torque to  $20 \pm 2$  ft\*lbs.
10. Attach the 3/8" ring tongue end of the 50" cable to the curb side stud of the clamp. Secure using the hardware supplied with the clamp. Secure and orientate as shown in Figure 3. Torque the hardware to  $20 \pm 2$  ft\*lbs. Route the other end of the cable to the rear of the street side engine rail. See Figure 7.

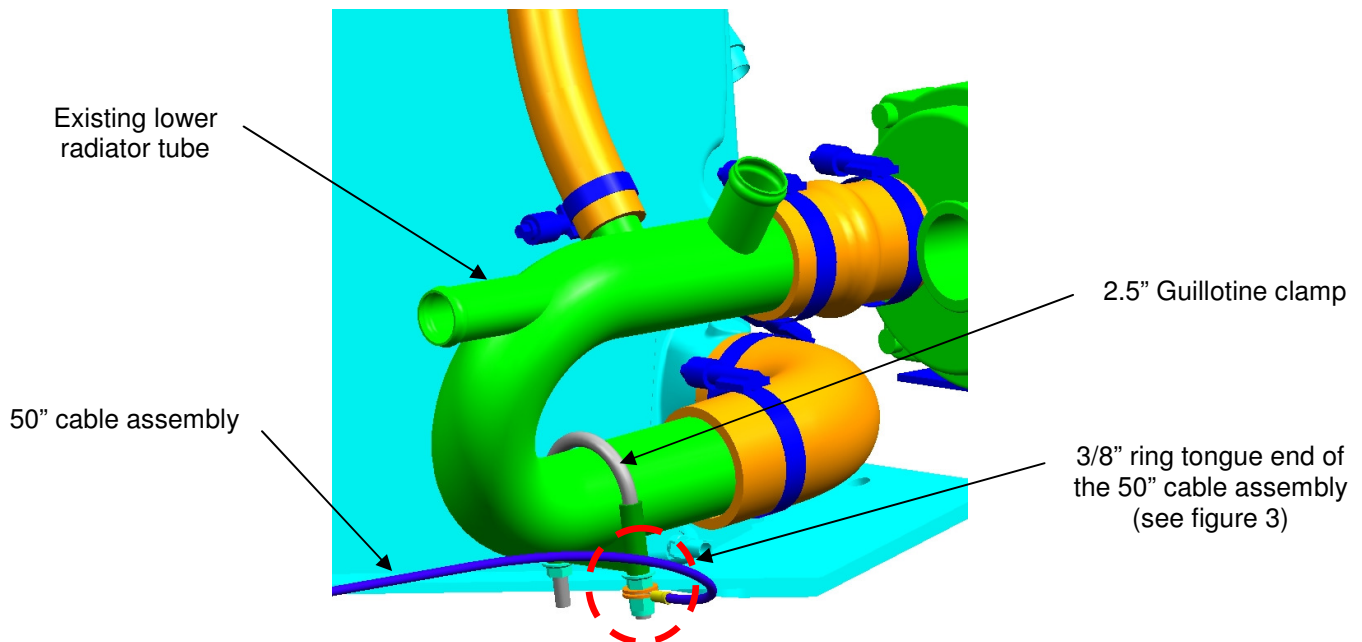

**Figure 6: Lower Coolant Tube Ground Strap**



## NEW FLYER

11. Route ground wires to area approximately 4.5" forward of the welded rail (See Figure 7), routing wire away from any hot surfaces or sharp edges. Use zip ties to secure wire at 18-24" intervals. Adjust clamp locations on coolant pipes if necessary.
12. Drill a .281Ø (9/32") hole for grounding stud. Remove structural coating from rail at washer contact to allow for proper ground contact. Attach upper and lower radiator tubes and shroud grounding straps. Torque ¼ UNC x 0.75 bolt to 12 ±2 ft-lbs.
13. Apply a protective coating over the installation.

**CAUTION:** Fan shroud must not be grounded to the chassis unless the pipes are also grounded.



**Figure 7: Common Ground Point on Bus Frame**

14. If necessary, lower coach in accordance with the New Flyer Service Manual.
15. Turn the main battery disconnect switch to the "ON" position.



**NEW FLYER**

### LABOUR ESTIMATE

	Operation	Men	Hours	Labour Time M X HR
1	Add EMP Radiator Ground Straps	1	0.5	0.5

### PARTS REQUIRED

Item	Part Number	Description	Qty. per Coach	Units	Notes
1	6449008	Kit-EMP Radiator Ground Strap Rework	1	EA	Vpn 1370056042