



SB-10057688-4680

© Jaguar Land Rover North America, LLC

NOTE: The information in Technical Bulletins is intended for use by trained, professional Technicians with the knowledge, tools, and equipment required to do the job properly and safely. It informs these Technicians of conditions that may occur on some vehicles, or provides information that could assist in proper vehicle service. The procedures should not be performed by 'do-it-yourselfers'. If you are not a Retailer, do not assume that a condition described affects your vehicle. Contact an authorized Land Rover service facility to determine whether this bulletin applies to a specific vehicle.

SECTION: 418-00

ECO Stop/Start Inoperative DTC B1479-73 Stored in GateWay Module

AFFECTED VEHICLE RANGE:

Range Rover Evoque (LV)

Model Year: 2014-2015

VIN: EH856580-FH002942

LR4 (LA)

Model Year: 2014-2015

VIN: EA699716-FA741486

MARKETS:

NAS

CONDITION SUMMARY:

Situation: The Eco Stop/Start function may be inoperative and Diagnostic Trouble Code (DTC) B1479-73 is stored the GateWay Module (GWM).

Cause: This may be caused by poor DTC logging strategy for GateWay Module B1479 73 DTC.

Action: Should a customer express this concern, follow the Service Instruction outlined below.

PARTS:

LR067367 Dual battery junction box (DBJB) Quantity: 1

TOOLS:

Refer to Workshop Manual for any required special tools.

WARRANTY:

△ **NOTE:** Repair procedures are under constant review, and therefore times are subject to change; those quoted here must be taken as guidance only. Always refer to TOPIx to obtain the latest repair time.

△ **NOTE:** DDW requires the use of causal part numbers. Labor only claims must show the causal part number with a quantity of zero.

DESCRIPTION	SRO	TIME (HOURS)	CONDITION CODE	CAUSAL PART
Dual Battery Junction Box - Renew - LR4 (L319)	86.71.26	0.3	42	LR048786
Dual Battery Junction Box - Renew - Range Rover Evoque (L538)	86.71.26	1.1	42	LR048786

△ **NOTE:** Normal Warranty procedures apply.

SERVICE INSTRUCTION:

△NOTE: the Dual Battery Junction Box (DBJB) may also be referred to as the Power Supply Distribution Box (PSDB).

△NOTE: removal steps in this procedure may contain installation details.

△NOTE: some variation in the illustrations may occur, but the essential information is always correct.

△NOTE: RHD shown, LHD similar.

1. Connect the Jaguar Land Rover-approved Midtronics battery power supply to the vehicle battery.
2. Connect the Symptom Driven Diagnostics (SDD) system to the vehicle, begin a new session, and read Diagnostic Trouble Codes (DTC).
 - If DTC B1479-73 is stored in the GateWay module, continue to next step to replace the Dual Battery Junction Box (DBJB).
 - If the DTC is not stored continue with diagnosis using SDD and with reference to TOPIx Workshop Manual; do not continue with this bulletin.
3. Disconnect the battery ground cable (see TOPIx Workshop Manual, section 414-01).

LR4 Only

4. Remove the auxiliary battery cover.



5. Remove the retaining nuts and position the electrical wiring to one side.

- Torque: 10Nm

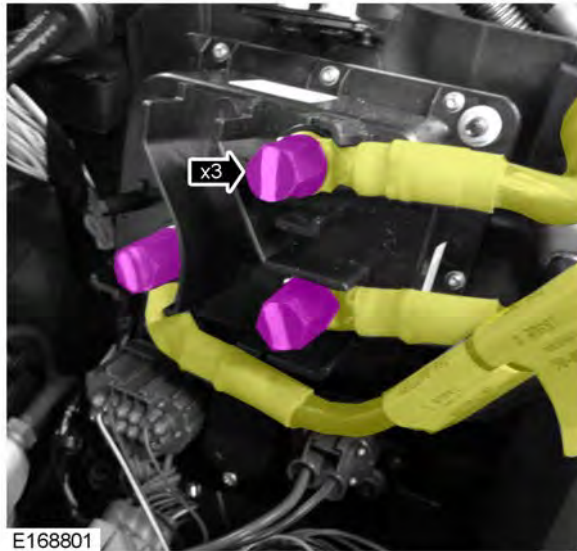

6. Disconnect the electrical connectors and position the electrical wiring harness to one side.

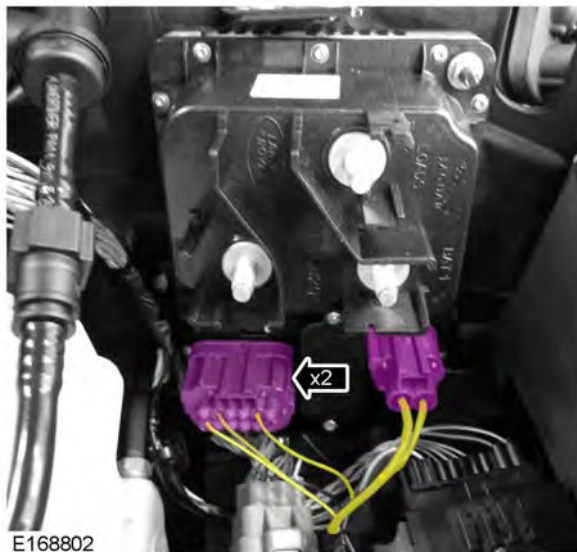

7. Remove the retaining nuts from the DBJB and remove from the mounting bracket.

- Torque: 9Nm

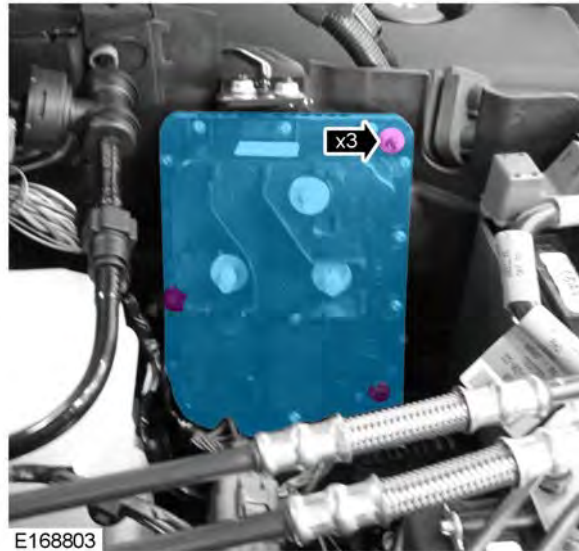

8. To install, reverse the removal procedure.

Range Rover Evoque Only

9. Disconnect the secondary battery ground cable.

- Torque: 6Nm

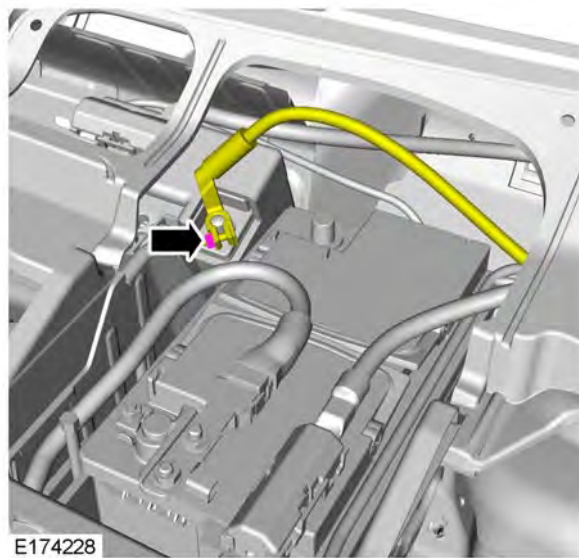

10. Disconnect the secondary battery positive connection and position the cable to one side.

- Torque: 6Nm

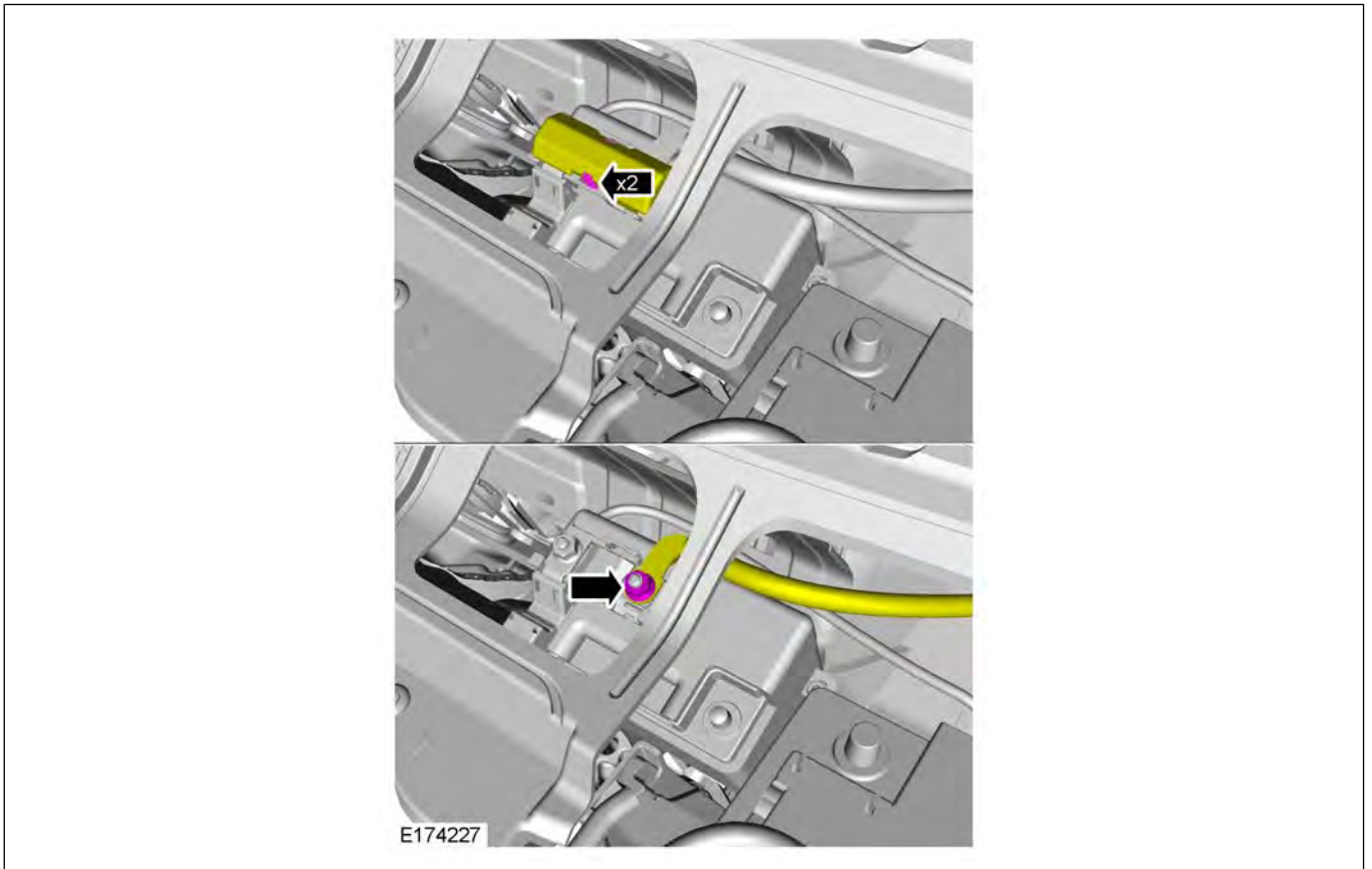

11. Remove the retaining clip and position the cowl panel to one side.

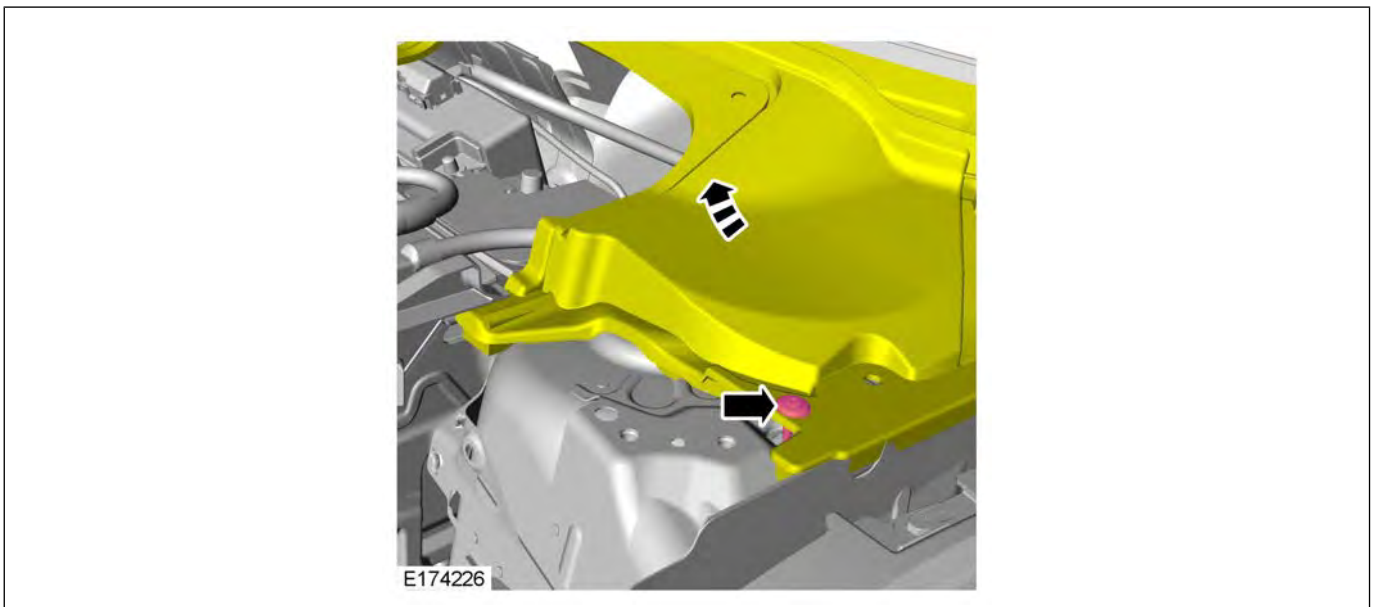

12. Disconnect the battery positive connection and position the cable to one side.

- Torque: 10Nm

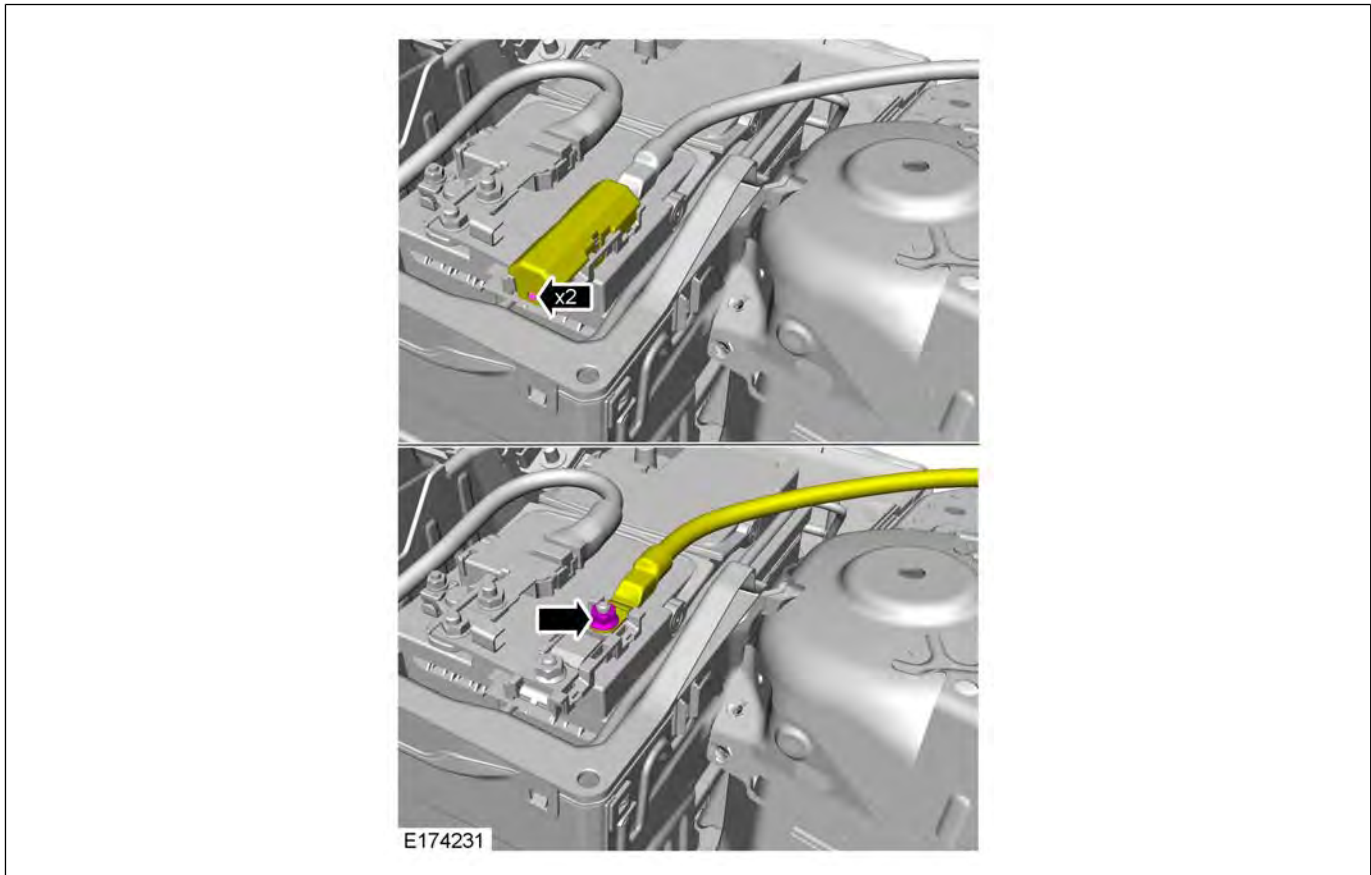

13. Remove the cover.

- Disconnect the battery cable and position to one side.

- Torque: 10Nm

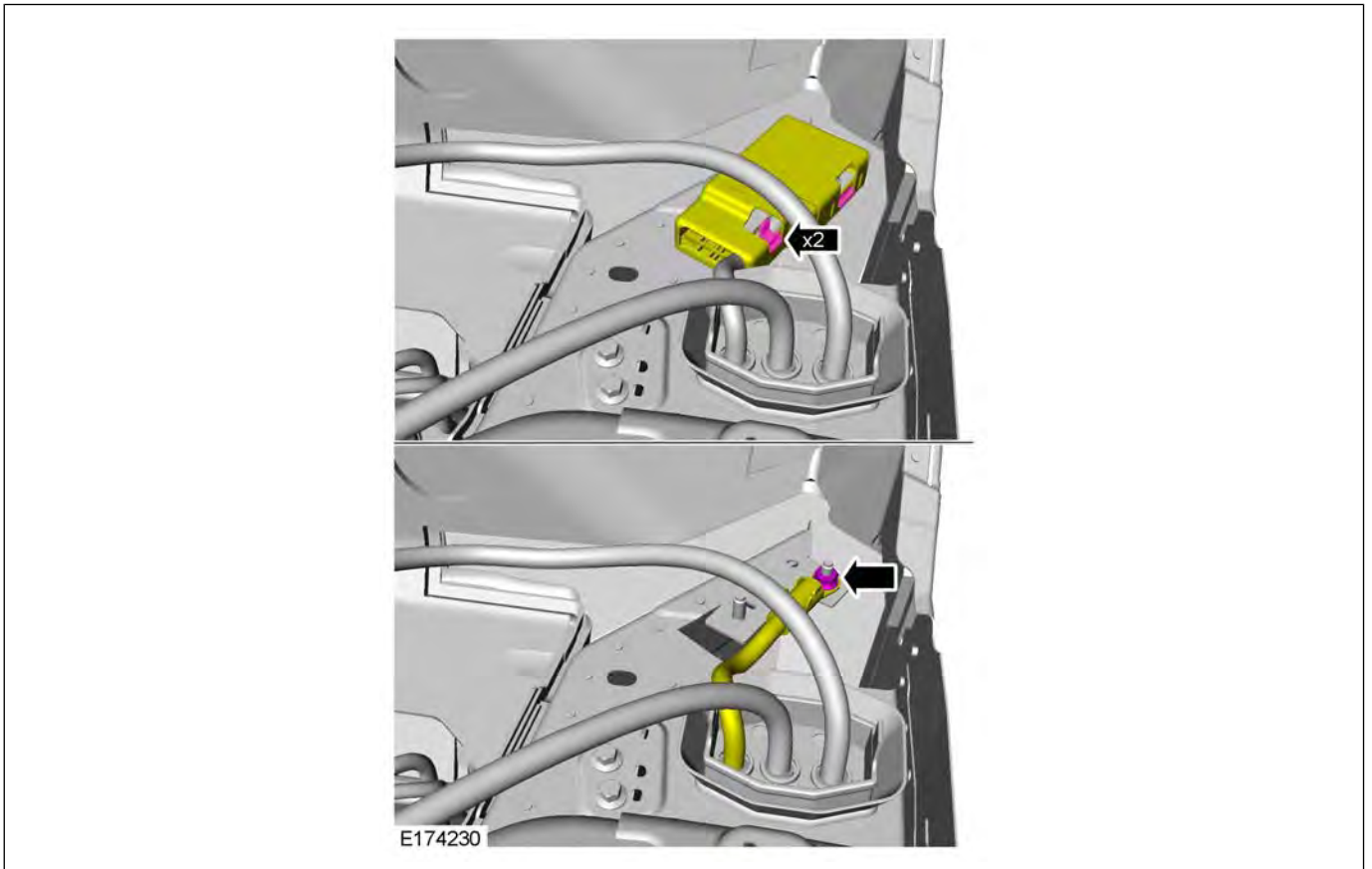

14. Remove battery cables from the vehicle body.

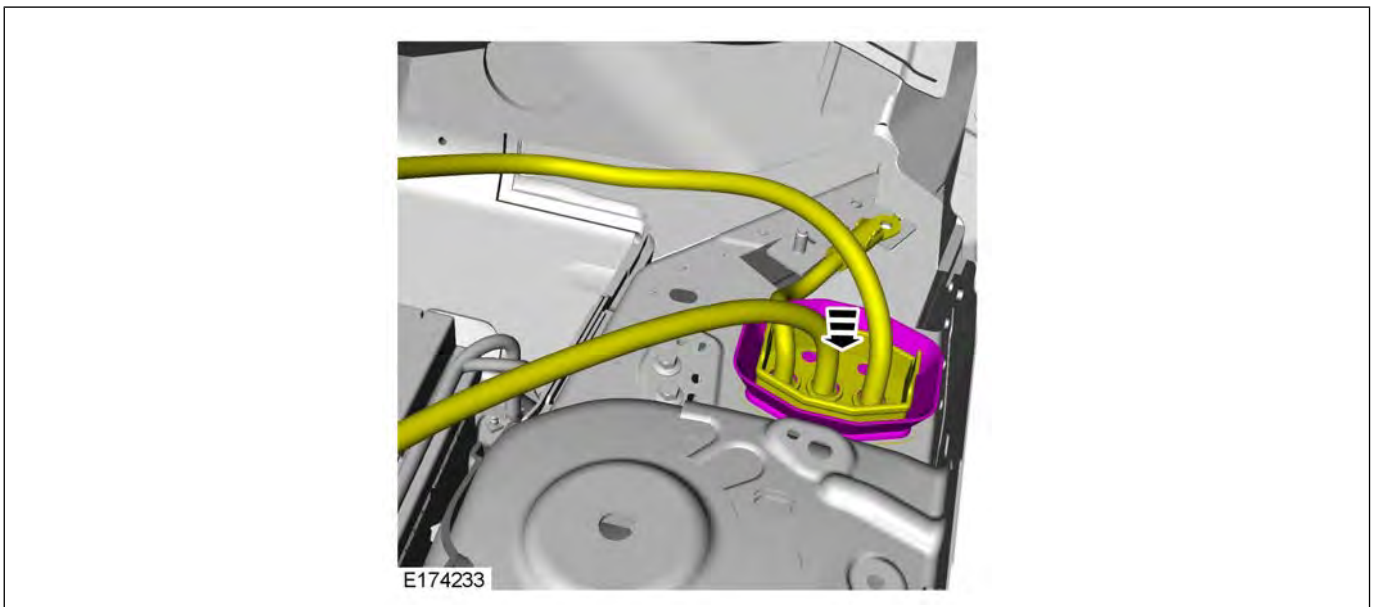

15. **▲WARNING:** make sure to support the vehicle with axle stands.

Raise and support the vehicle.

16. Remove the front left fender splash shield (see TOPIx Workshop Manual, section 501-02).

17. Release the electrical connectors from the bracket and position the electrical wiring harness to one side.

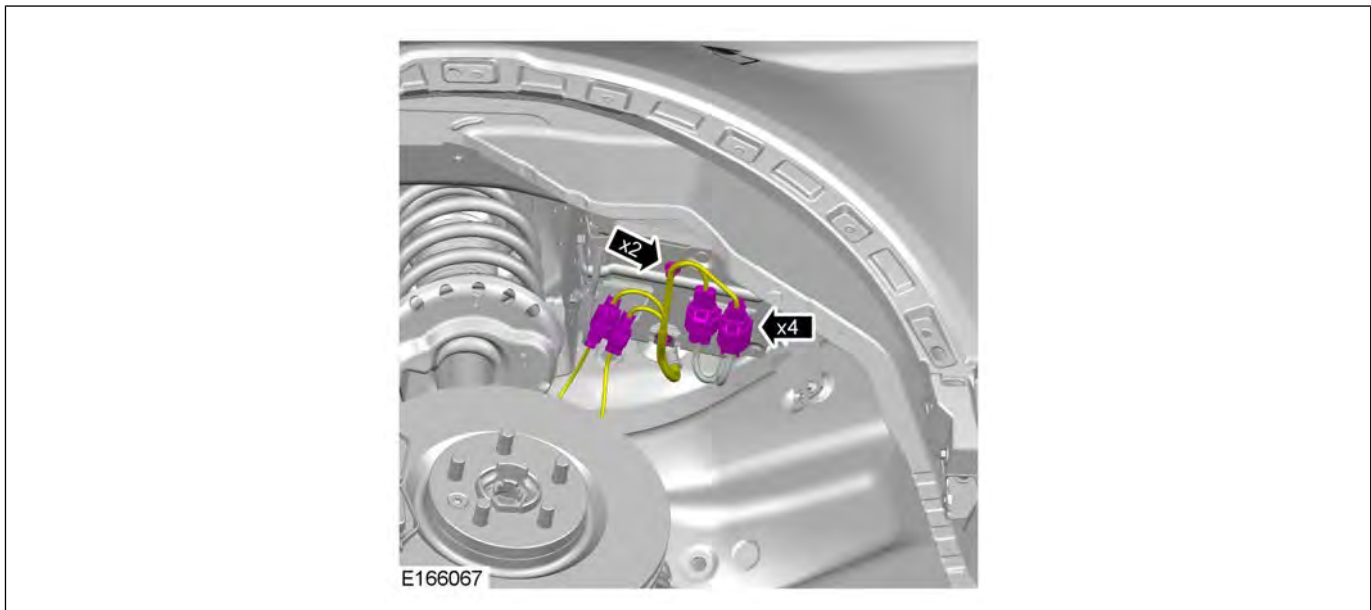

18. Remove the retaining clip and position the battery drain hose to one side.

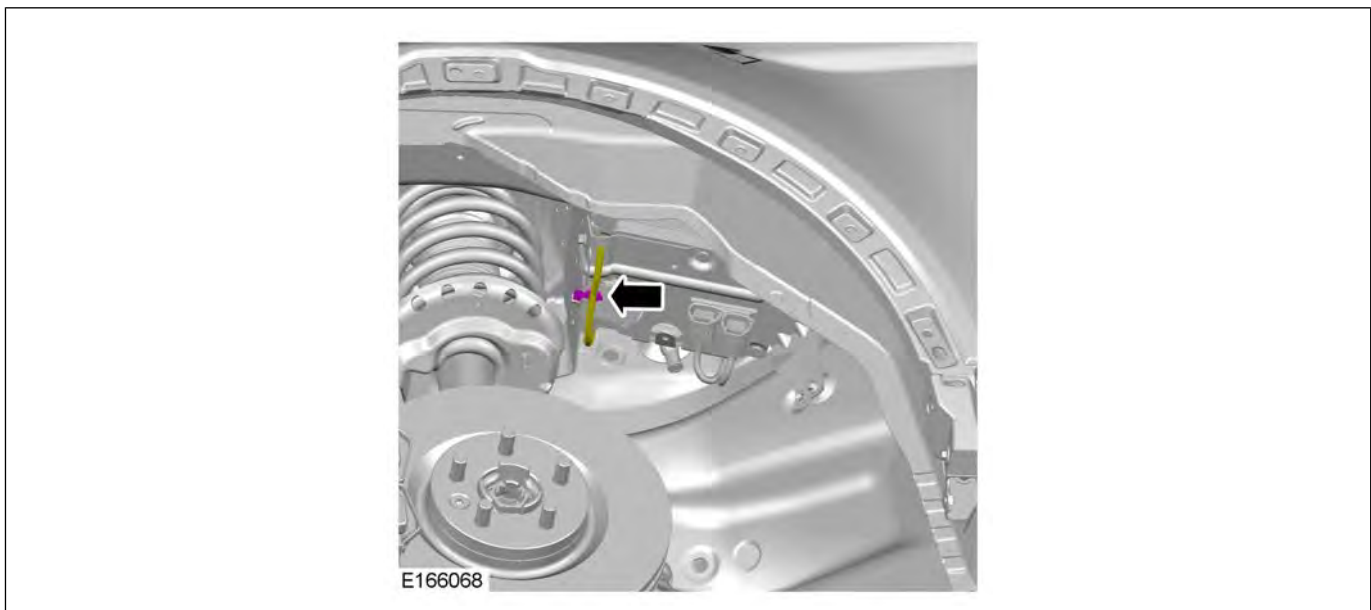

19. Remove the retaining bolts and the DBJB with mounting bracket.

- Torque: 10Nm



20. Disconnect the electrical connectors from the DBJB and position the electrical wiring harness to one side.

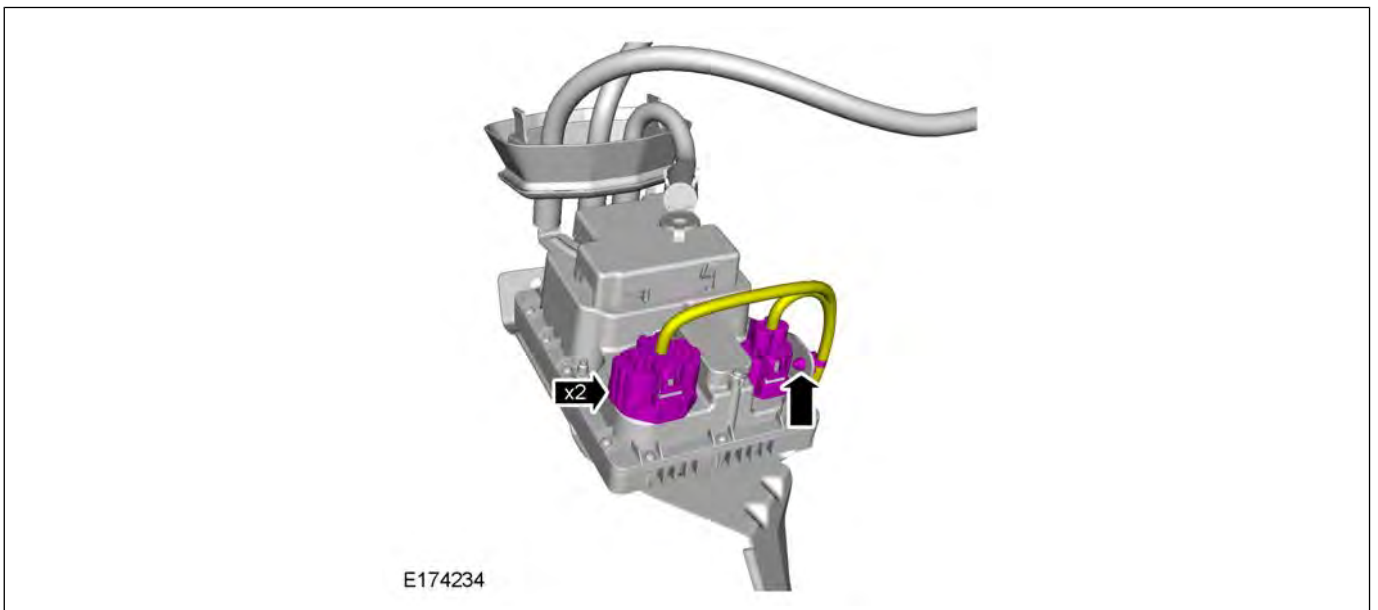

21. **⚠ CAUTION:** note the fitted position of the battery cables prior to removal.

Remove the cover from the DBJB.

- Remove the battery cable retaining nuts.

- Torque: 9Nm

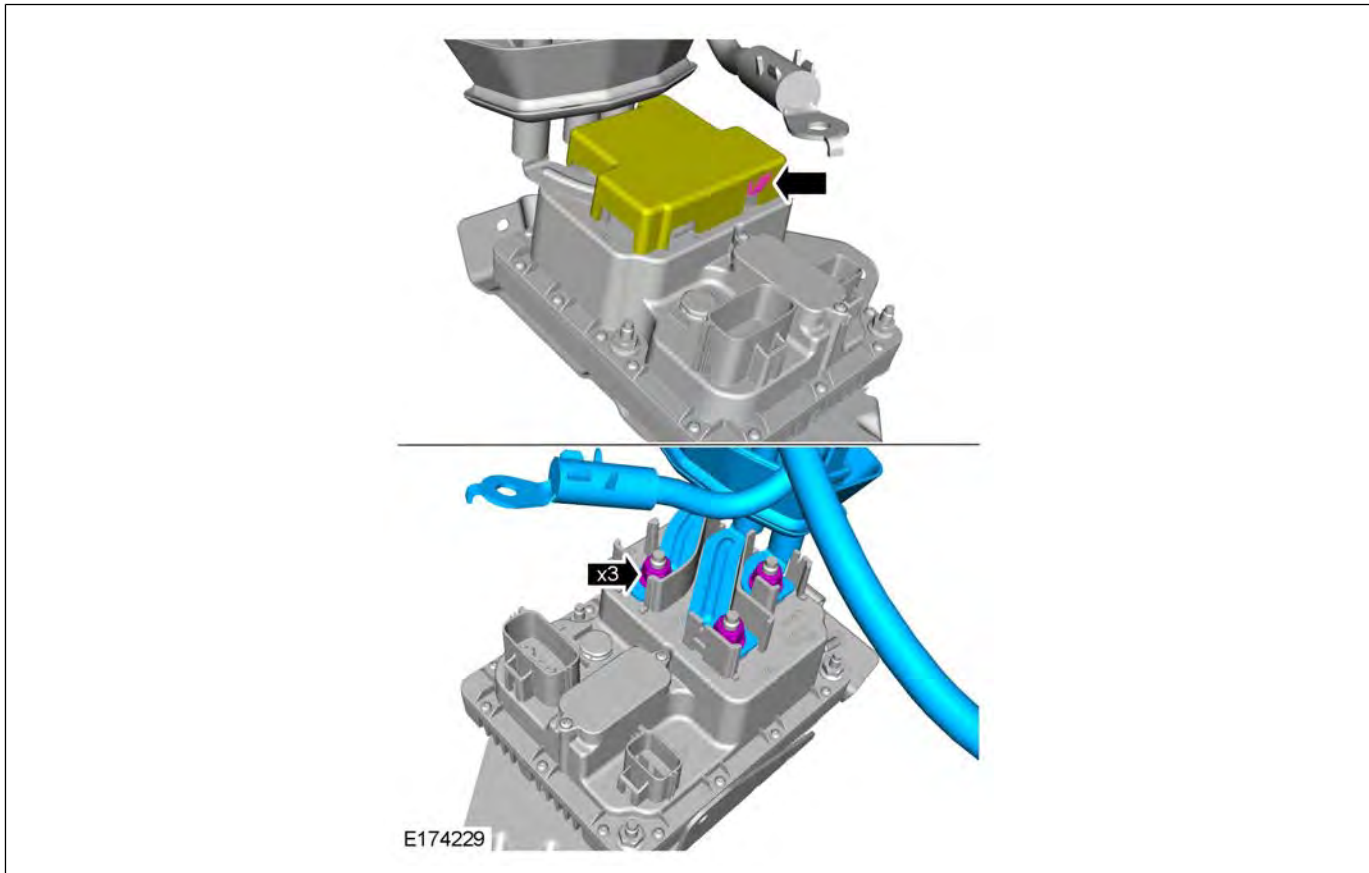

22. Remove the retaining nuts from the DBJB.

- Remove the DBJB from the mounting bracket.
- Torque: 9Nm



23. To install, reverse the removal procedure.

LR4 and Range Rover Evoque

24. Use SDD to clear all DTCs.
25. Exit the current session.
26. Disconnect the SDD and the battery power supply from the vehicle.