



# Service Bulletin



## SPECIAL COVERAGE

**SUBJECT: Special Coverage Adjustment - Torque Converter Clutch Wear**

**MODELS: 2010-2014 Chevrolet Express  
2010-2014 GMC Savana  
Equipped 6.0L Flexible Fuel Engine (RPO L96) and 6-Speed Automatic  
Transmission (RPO MYD)**

### CONDITION

Certain 2010-2014 model year Chevrolet Express and GMC Savana model vehicles, equipped with a 6.0L flexible fuel engine (RPO L96) and 6-speed automatic transmission (RPO MYD), may have a condition in which high duty cycle use while pulling trailers and/or vehicles (such as fleet customers driving cut-away models with 16 foot boxes) can exceed the target energy input to the clutch. This may lead to faster torque converter clutch friction material wear than expected. Some operators of vehicles with this condition have reported a driveline vibration or shudder feeling.

### SPECIAL COVERAGE ADJUSTMENT

This special coverage covers the condition described above for a period of 10 years or 120,000 miles (193,000 km), whichever occurs first, from the date the vehicle was originally placed in service, regardless of ownership.

Dealers are to replace the torque converter and reprogram the Transmission Control Module (TCM). The repairs will be made at no charge to the customer.

For vehicles covered by Vehicle Service Contracts, all eligible claims with repair orders on or after January 27, 2015 are covered by this special coverage and must be submitted using the labor operation codes provided with this bulletin. Claims with repair orders prior to January 27, 2015 must be submitted to the Service Contract provider.

### VEHICLES INVOLVED

All involved vehicles are identified by Vehicle Identification Number on the Applicable Warranties section in GM Global Warranty Management system. Dealership service personnel should always check this site to confirm vehicle involvement prior to beginning any required inspections and/or repairs. It is important to routinely use this tool to verify eligibility because not all similar vehicles may be involved regardless of description or option content.

PART INFORMATION

Parts required to complete this special coverage are to be obtained from General Motors Customer Care and Aftersales (GMCC&A).

Part Number	Description	Quantity/Vehicle
17804388	Torque Converter	1
15251488	Seal, Trans Fluid CLR Pipe FTG	1
88861037	Fluid, A/Trans Dexron VI	10
15077362	Exhaust Manifold Seals	2
15027074	Exhaust Muffler Gasket	1

SERVICE PROCEDURE

1. Determine if the torque converter requires replacement using the appropriate diagnostic information in SI.
  - If the torque converter does NOT require replacement, ensure Customer Satisfaction Program 14730 has been completed BEFORE returning the vehicle to the customer. Inform the customer that any additional diagnosis and repairs are not covered under this special coverage. No further action is required.
  - If the torque converter requires replacement, proceed to step 2.
2. Determine if Customer Satisfaction Program 14730 has been completed.
  - If Customer Satisfaction Program 14730 has been completed, proceed to step 3.
  - If Customer Satisfaction Program 14730 has NOT been completed, proceed to step 3. After replacing the torque converter, reprogram the transmission control module (TCM) as instructed in Customer Satisfaction Program 14730. Complete Customer Satisfaction Program 14730 BEFORE returning the vehicle to the customer.

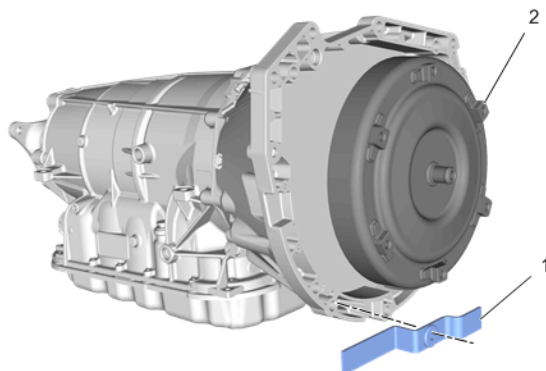

3788176

3. Remove the torque converter (2) from the transmission. Refer to *Torque Converter Replacement* in SI.
4. Install a new torque converter (2). Refer to *Torque Converter Replacement* in SI.

### CUSTOMER REIMBURSEMENT - For US

Customer requests for reimbursement of previously paid repairs to correct the condition described in this bulletin are to be submitted to the dealer by January 31, 2016 unless otherwise specified by state law. If this is not convenient for the customer, they may mail the completed Customer Reimbursement Request Form and all required documents to the GM Customer Assistance Center. Repairs must have occurred within the 10 years of the date the vehicle was originally placed in service, or 120,000 miles, whichever occurs first.

**All reasonable and customary costs to correct the condition described in this bulletin should be considered for reimbursement. Any questions or concerns should be reviewed with your GM representative prior to processing the request.**

When a customer requests reimbursement, they must provide the following:

- A completed Customer Reimbursement Request Form. This form is mailed to the customer or can be obtained through GM GlobalConnect.
- The name and address of the person who paid for the repair.
- Paid receipt confirming the amount of the repair expense, a description of the repair, and the person or entity performing the repair.

**IMPORTANT:** GM requires dealers to approve or deny a reimbursement request within 30 days of receipt. If a reimbursement request is approved, the dealer should immediately issue a check to the customer and submit an appropriate warranty transaction for the incurred expense. If a reimbursement request is denied, the dealer MUST provide the customer with a clear and concise explanation, in writing, as to why the request was denied. The bottom portion of the Customer Reimbursement Request Form may be used for this purpose. If the denial was due to missing documents, the customer can resubmit the request when the missing documents are obtained, as long as it is still within the allowed reimbursement period.

Warranty transactions for customer reimbursement of previously paid repairs are to be submitted as required by GM Global Warranty Management. Additional information can also be found in Warranty Administration Bulletin 11-00-89-004.

### CUSTOMER REIMBURSEMENT - For Canada and Export

Customer requests for reimbursement of previously paid repairs to correct the condition described in this bulletin are to be submitted to the dealer prior to or by January 31, 2016. Repairs must have occurred within the 10 years of the date the vehicle was originally placed in service, or 193,000 kilometers, whichever occurs first.

When a customer requests reimbursement, they must provide the following:

- Proof of ownership at time of repair.
- Original paid receipt confirming the amount of unreimbursed repair expense(s) (including Service Contract deductibles), a description of the repair, and the person or entity performing the repair.

All reasonable and customary costs to correct the condition described in this bulletin should be considered for reimbursement. Any questions or concerns should be reviewed with your GM representative prior to processing the request.

COURTESY TRANSPORTATION – For US and Canada

The General Motors Courtesy Transportation program is intended to minimize customer inconvenience when a vehicle requires a repair that is covered by the New Vehicle Limited Warranties. The availability of courtesy transportation to customers whose vehicles are within the warranty coverage period and involved in a product program is very important in maintaining customer satisfaction. Dealers are to ensure that these customers understand that shuttle service or some other form of courtesy transportation is available and will be provided at no charge. Dealers should refer to the General Motors Service Policies and Procedures Manual for Courtesy Transportation guidelines.

WARRANTY TRANSACTION INFORMATION

Submit a transaction using the table below. All transactions should be submitted as a ZREG transaction type, unless noted otherwise.

**Note:** To avoid having to "H" route the customer reimbursement transaction for approval, it must be submitted prior to the repair transaction.

Labor Code	Description	Labor Time	Net Item
9900102	Diagnostic Time Only – No Repair Required	0.3	N/A
8464810	Torque Converter Replacement – For use with vehicles still covered under warranty	3.9	N/A
9900103	Torque Converter Replacement – For use with vehicles no longer covered under warranty	3.9	N/A
9900104	Customer Reimbursement Approved	0.2	*
9900105	Customer Reimbursement Denied - For US dealers only	0.1	N/A

\* The amount identified in "Net Item" should represent the dollar amount reimbursed to the customer.

CUSTOMER NOTIFICATION

General Motors will notify customers of this special coverage on their vehicles (see copy of typical customer letter included with this bulletin - actual divisional letter may vary slightly)



January 2015

Dear General Motors Customer:

As the owner of a Chevrolet Express or GMC Savana model vehicles, equipped with a 6.0L flexible fuel engine and 6-speed automatic transmission, your satisfaction with our product is very important to us.

This letter is intended to make you aware that some 2010-2014 model year Chevrolet Express or GMC Savana vehicles may have been built with a condition in which high duty cycle use while pulling trailers and/or vehicles (such as fleet customers driving cut-away models with 16 foot boxes) can exceed the target energy input to the clutch. This may lead to faster torque converter clutch friction material wear than expected. Some operators of vehicles with this condition have reported a driveline vibration or shudder feeling.

**Do not take your vehicle to your GM dealer as a result of this letter unless you believe that your vehicle has the condition as described above.**

**What We Have Done:** General Motors is providing owners with additional protection for the condition described above. If this condition occurs on your 2014 model year Express or Savana within 10 years of the date your vehicle was originally placed in service or 120,000 miles (193,000 km), whichever occurs first, the condition will be repaired for you at **no charge**. Diagnosis or repair for conditions other than the condition described above is not covered under this special coverage program.

**What You Should Do:** If you believe that your vehicle has the condition described above, repairs and adjustments qualifying under this special coverage must be performed by a General Motors dealer. You may want to contact your GM dealer to find out how long they will need to have your vehicle so that you may schedule the appointment at a time that is convenient for you. This will also allow your dealer to order parts if they are not already in stock. Keep this letter with your other important glove box literature for future reference.

**Reimbursement:** If you have paid for repairs for the condition described in this letter, please complete the enclosed reimbursement form and present it to your dealer with all required documents. Working with your dealer will expedite your request, however, if this is not convenient, you may mail the completed reimbursement form and all required documents to Reimbursement Department, PO Box 33170, Detroit, MI 48232-5170. The completed form and required documents must be presented to your dealer or received by the Reimbursement Department by January 31, 2016 unless state law specifies a longer reimbursement period.

If you have any questions or need any assistance, just contact your dealer or the appropriate Customer Assistance Center at the number listed below.

Division	Number	Text Telephones (TTY)
Chevrolet	1-800-222-1020	1-800-833-2438
GMC	1-800-462-8782	1-888-889-2438
Guam	65-6267-1752	
Puerto Rico – English	1-800-496-9992	
Puerto Rico – Español	1-800-496-9993	
Virgin Islands	1-800-496-9994	

We are sorry for any inconvenience you may experience; however, we have taken this action in the interest of your continued satisfaction with our products.

Alicia S. Boler-Davis  
Sr. Vice President  
Global Quality & Customer Experience

Enclosure  
14745