

TECHNICAL BULLETIN
JTB00292NAS2
18 JUN 2015

SB-10052595-6844



© Jaguar Land Rover North America, LLC

NOTE: The information in Technical Bulletins is intended for use by trained, professional Technicians with the knowledge, tools, and equipment required to do the job properly and safely. It informs these Technicians of conditions that may occur on some vehicles, or provides information that could assist in proper vehicle service. The procedures should not be performed by 'do-it-yourselfers'. If you are not a Retailer, do not assume that a condition described affects your vehicle. Contact an authorized Jaguar service facility to determine whether this bulletin applies to a specific vehicle.

This reissue replaces all previous versions. Please destroy all previous versions.

Changes are highlighted in gray

SECTION: 501-14

Freezing Latch / Door Will Not Close

AFFECTED VEHICLE RANGE:

XF (X250)

Model Year: 2012-2014

VIN: CDS50323-EDS77552

XJ Range (X351)

Model Year: 2012-2013

VIN: CFV36871-DPV47979

XK Range (X150)

Model Year: 2012-2013

VIN: CLB47844-DLB49050

MARKETS:

NAS

CONDITION SUMMARY:

Situation: The front door may not close after being opened using the exterior handle.

Cause: This may be caused by the outer door handle cable freezing in the sleeve.

Action: In the event of a customer concern of the above, refer to the Service Instruction outlined below.

PARTS:



NOTE: due to the likelihood of breakage during removal, door veneer-to-door trim clips (C2D10041 x4) are required for XJ.

C2P14340	Front door latch cable	Quantity: 2
C2D10041	Clip (XJ only)	Quantity: 4

WARRANTY:



NOTE: Repair procedures are under constant review, and therefore times are subject to change; those quoted here must be taken as guidance only. Always refer to TOPIx to obtain the latest repair time.



NOTE: DDW requires the use of causal part numbers. Labor only claims must show the causal part number with a quantity of zero.

DESCRIPTION	SRO	TIME (HOURS)	CONDITION CODE	CAUSAL PART

Cable - Driver exterior door handle to latch - Renew - XF	76.58.38	1.00	41	C2P14340
Cable - Passenger exterior door handle to latch - Renew - XF	76.58.39	1.00	41	C2P14340
Cable - Driver exterior door handle to latch - Renew - XJ	76.58.38	1.30	41	C2P14340
Cable - Passenger exterior door handle to latch - Renew - XJ	76.58.39	1.30	41	C2P14340
Cable - Driver exterior door handle to latch - Renew - XK	76.58.38	1.40	41	C2P14340
Cable - Passenger exterior door handle to latch - Renew - XK	76.58.39	1.40	41	C2P14340



NOTE: Normal Warranty procedures apply.

SERVICE INSTRUCTION:



NOTE: the outer door handle cables on both front left and right door latch assemblies must be replaced.

XF / XJ Only

1. Remove the front left door latch (refer to TOPIx Workshop Manual section 501-14).



2. **NOTE: note the installed position of the component prior to removal.**

Release the cable.

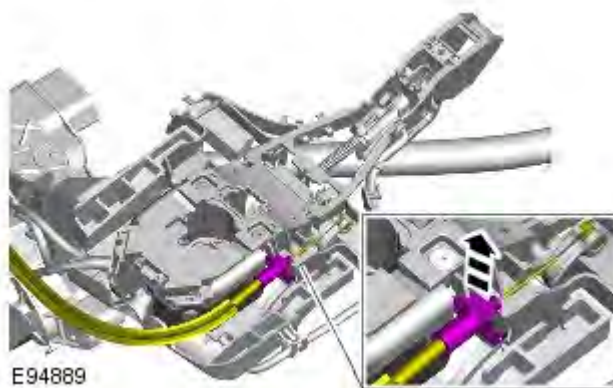

3. **NOTE: note the installed position of the component prior to removal.**

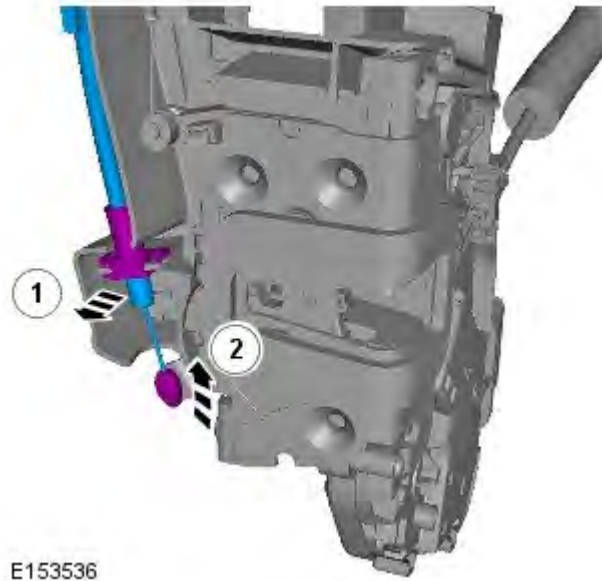

Remove the cable.



E153536

4. Reverse steps 1-3 to install the cable and latch.
5. Repeat steps 1-4 to the front right door.
6. Carry out door window motor initialization (refer to TOPIx Workshop Manual section 501-11).

XK Only

7.  **NOTE: make sure that the door glass is fully raised before removing the door trim panel.**
-  **NOTE: right door shown; left door similar.**
-  **NOTE: the outer door handle cables on both left and right door latch assemblies must be replaced.**

Remove the door trim panel (refer to TOPIx Workshop Manual section 501-05).

8. Remove the exterior door handle (refer to TOPIx Workshop Manual section 501-14).
9. Release the harness.
 - Disconnect the four (4) electrical connectors.
 - Release the 12 clips.

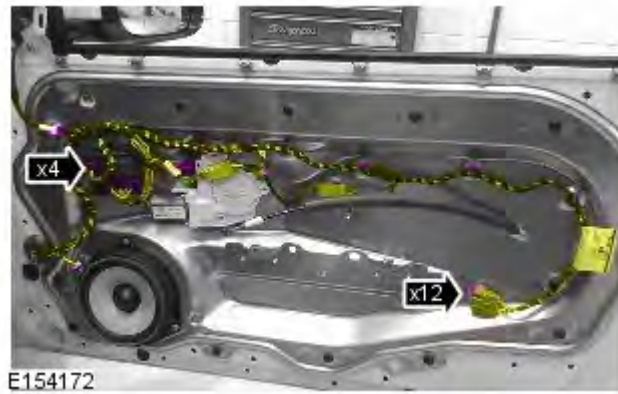

10. Remove the motor.

- Remove the three (3) Torx screws.

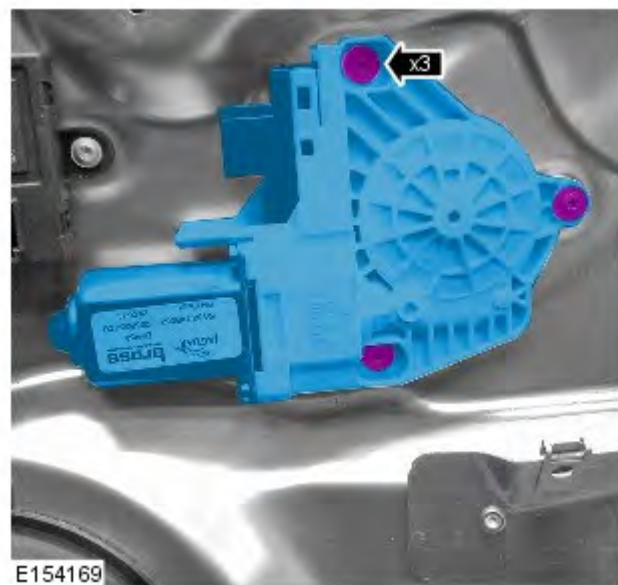

11. Remove the panel.

- Release the three (3) window regulator locating pegs.
- Remove the 13 Torx bolts.
- Release the cable.

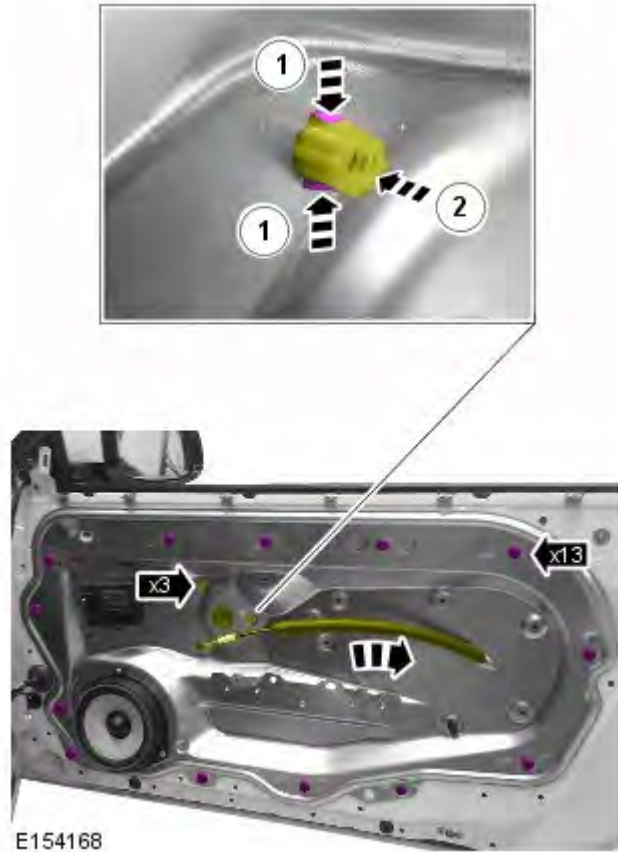

12.  **NOTE: note the installed position of the component prior to removal.**

Carefully release the waist seal.

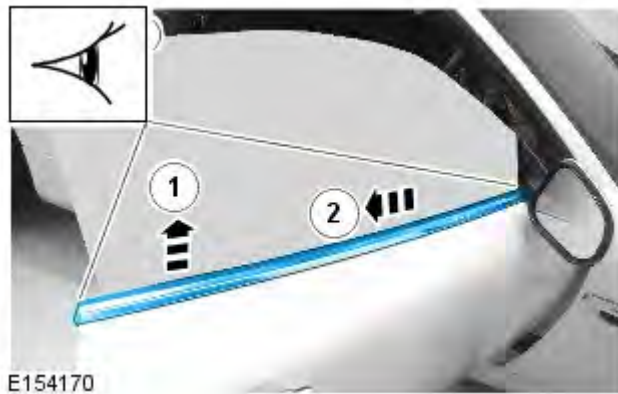

13.  **NOTE: note the installed position of the component prior to removal.**

Carefully remove the door glass.

- Slacken the Torx bolt.
- Slacken the bolt.

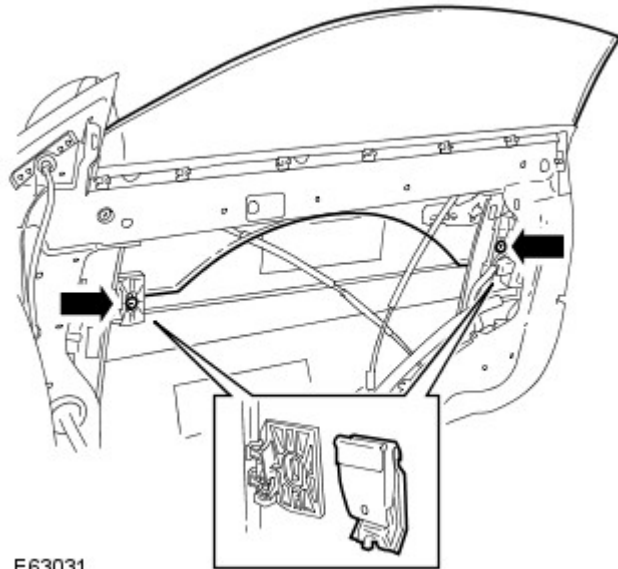

E63031

14. Remove the trim panel.

- Release the seven (7) clips.



E154166

15.  **CAUTION:** make sure that the cables are not damaged during this step.

 **NOTE:** note the installed position of the component prior to repositioning.

Reposition the window regulator.

- Remove the nut.
- Remove the two (2) Torx screws.

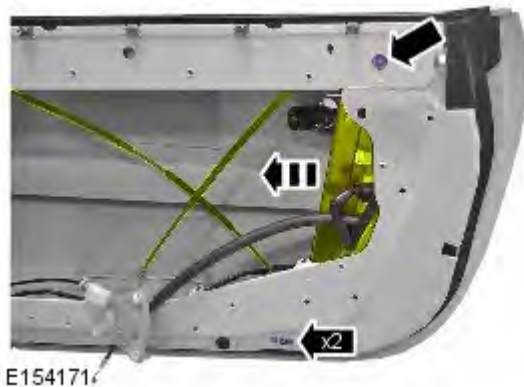

E154171

16. Release the door latch assembly.

- Remove the Torx screw.



17. Release the door latch assembly.

- Remove the three (3) Torx screws.

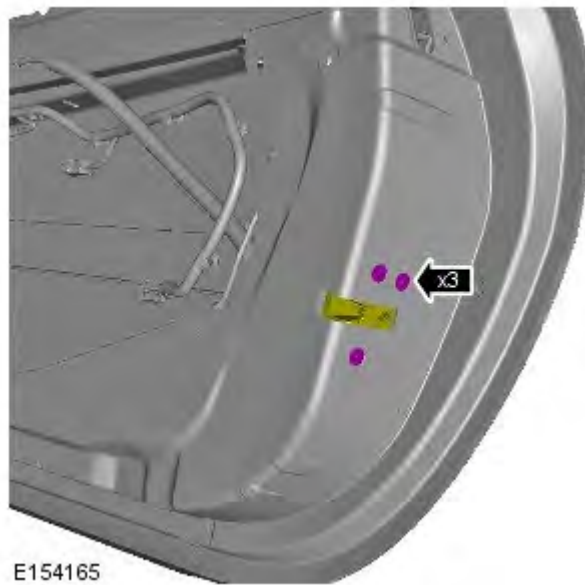

18. Remove the door latch assembly.

- Disconnect the three (3) electrical connectors.

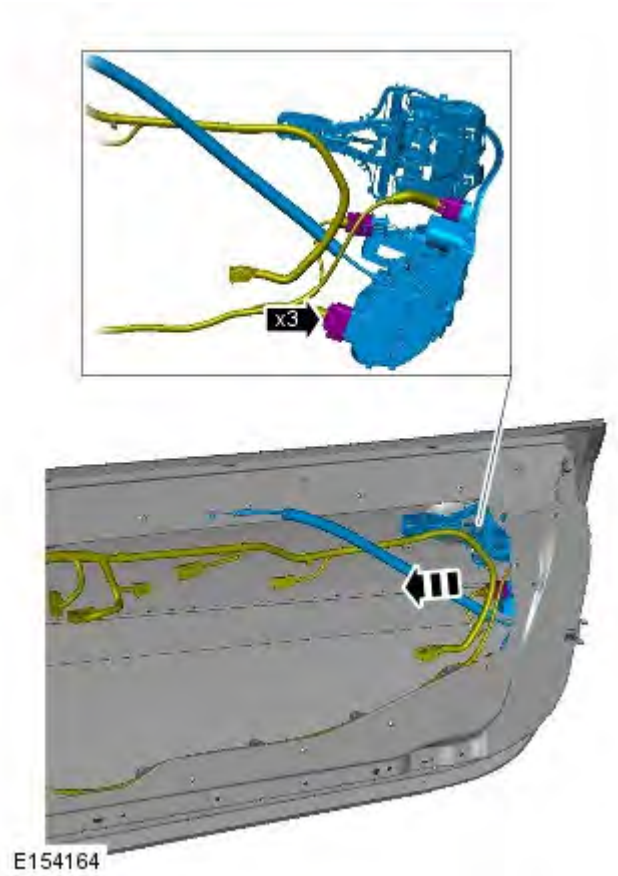

19.  **NOTE: note the installed position of the component prior to removal.**

Release the cable.

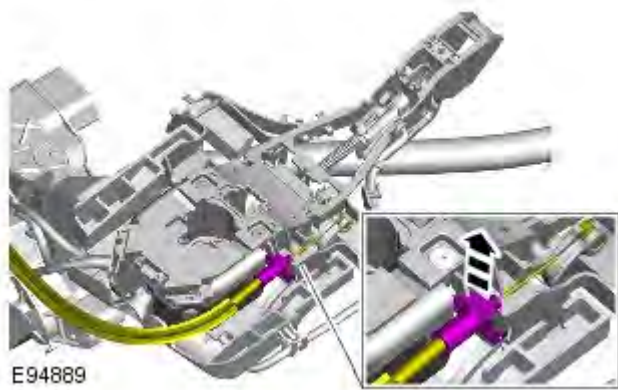

20.  **NOTE: note the installed position of the component prior to removal.**

Remove the cable.

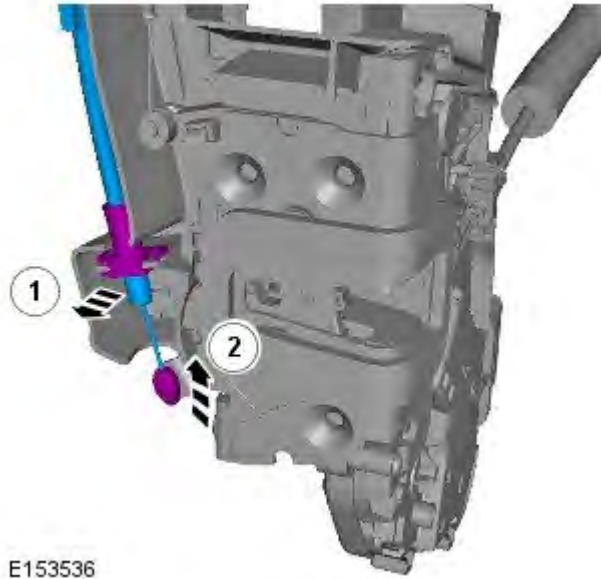

E153536

21. Reverse steps 19-20 to install the cable onto the latch.

22. Install the door latch assembly.

- Connect the three (3) electrical connectors.

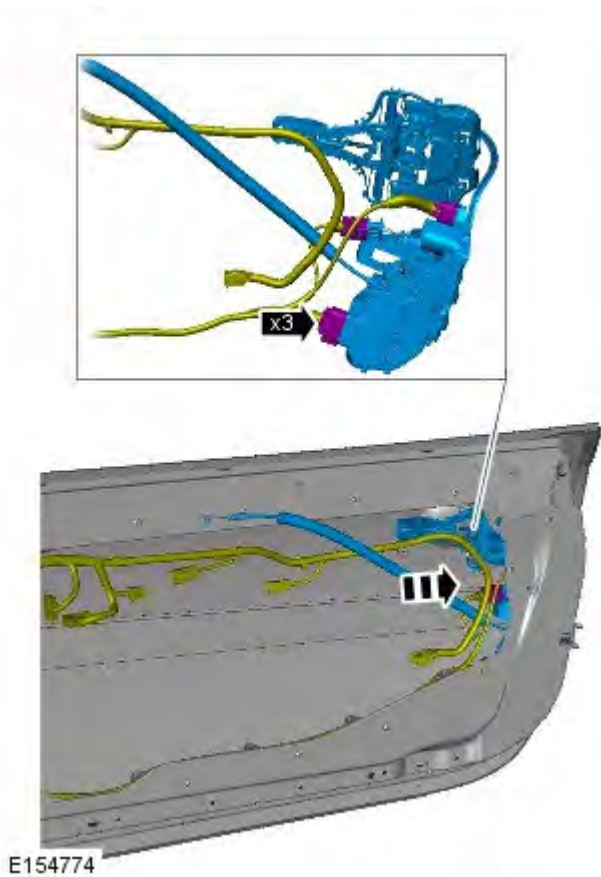

E154774

23. Secure the door latch assembly.

- Tighten the three (3) Torx screws to 7Nm.



24. Secure the door latch assembly.

- Tighten the Torx screw to 3Nm.



25.  **CAUTION: make sure that the cables are not damaged during this step.**

Secure the window regulator.

- Tighten the nut to 8Nm.
- Tighten the two (2) Torx screws to 4Nm.



26.  **NOTE: the door glass must be fully raised when carrying out measurements.**

Carefully install the door glass.

- Align the door glass longitudinally.
- Position the door glass, forwards or rearwards; the door glass edge should be 44mm from edge of door as shown in dimension 'A'.
- Tighten the Torx bolt to 8Nm.
- Tighten the bolt to 8Nm.

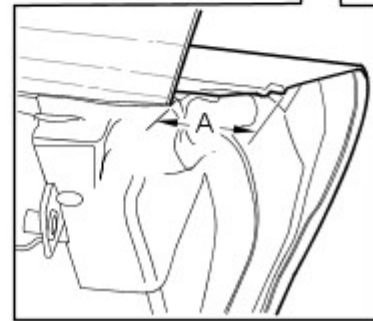
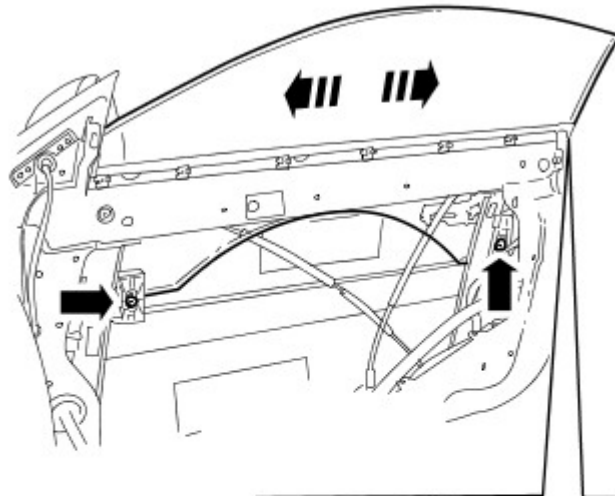

E64914

27. Carefully install the waist seal.

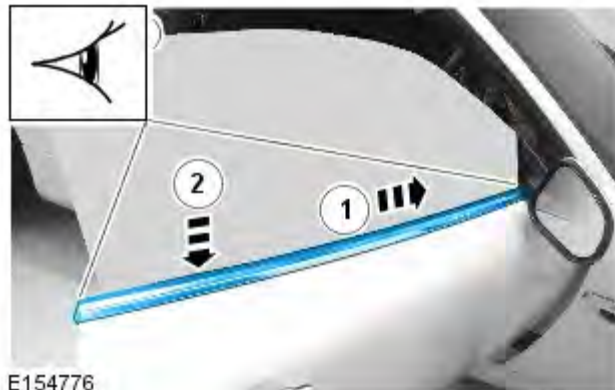

E154776

28. Install the panel.

- Secure the cable.
- Secure the three (3) window regulator locating pegs.
- Tighten the 13 Torx bolts to 10 Nm.

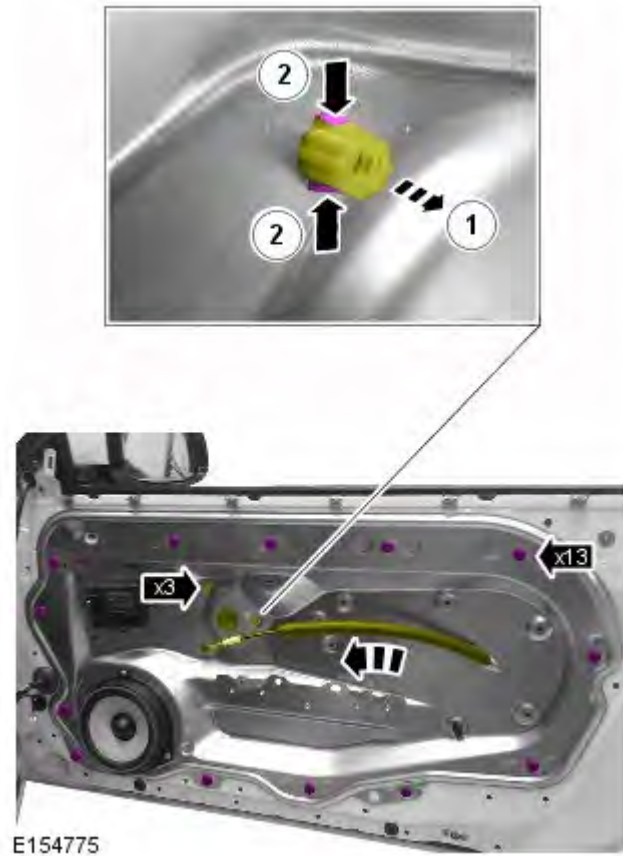

29. Install the motor.

- Tighten the three (3) Torx screws to 4 Nm.

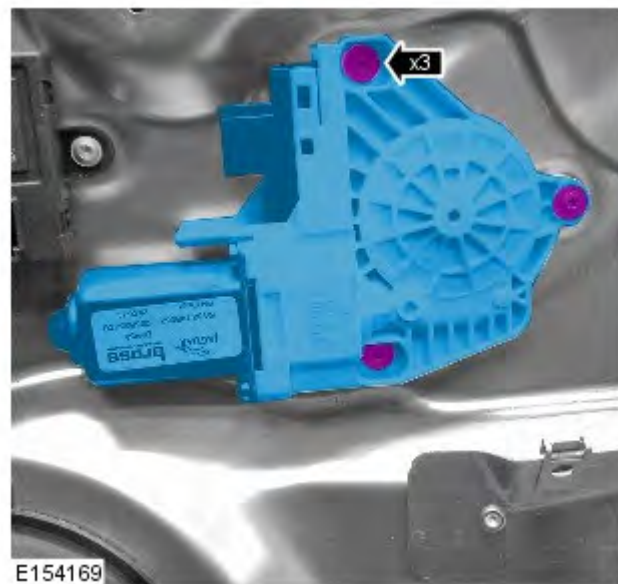

30. Secure the harness.

- Connect the four (4) electrical connectors.
- Secure the 12 clips.

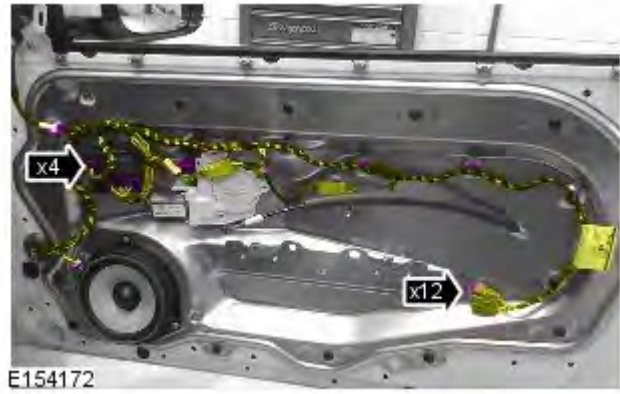

31. Install the exterior door handle (refer to TOPIx Workshop Manual section 501-14).

32. Install the front door trim panel (refer to TOPIx Workshop Manual section 501-05).

33. Repeat steps 7-32 to the left door.

34. Carry out door window motor initialization (refer to TOPIx Workshop Manual section 501-11).