

APPROXIMATE POSITION ON TRAILER				
MODEL	LTWCI	LTWCI	LTWCII, ELITE WCII, WC2-2	LTWCII, ELITE WCII, WC2-2
<b>KAWASAKI</b>	BOW STOP	BUNKS	BOW STOP	BUNKS
STX	17-18"	25"	17-18"	25"
ULTRA	17-18"	25"	17-18"	25"
<b>SEA-DOO</b>				
SPARK	12-13"	24"	13-14"	24"
GTS, GTR, GTI, WAKE155	14-15"	27"	15-16"	27"
RXT, GTX, WAKE215	15-16"	27"	16-17"	27"
RXP	15-16"	27"	16-17"	27"
<b>YAMAHA</b>				
V1, V1 Sport 2015, VX1 Prior to 2015	14-15"	25"	15-16"	25"
FX, FZS, FZR	14-15"	25"	15-16"	25"
VX 2015, VX Cruiser, VX Deluxe	14-15"	27"	15-16"	27"

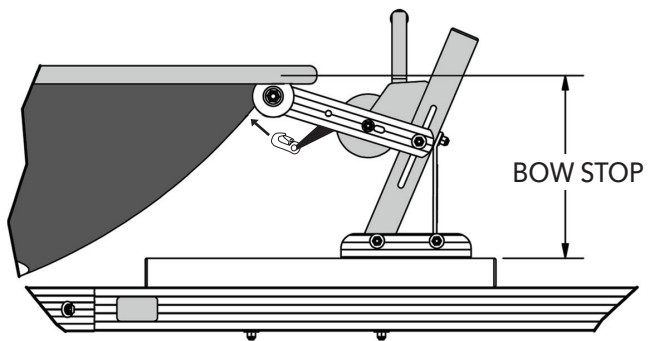
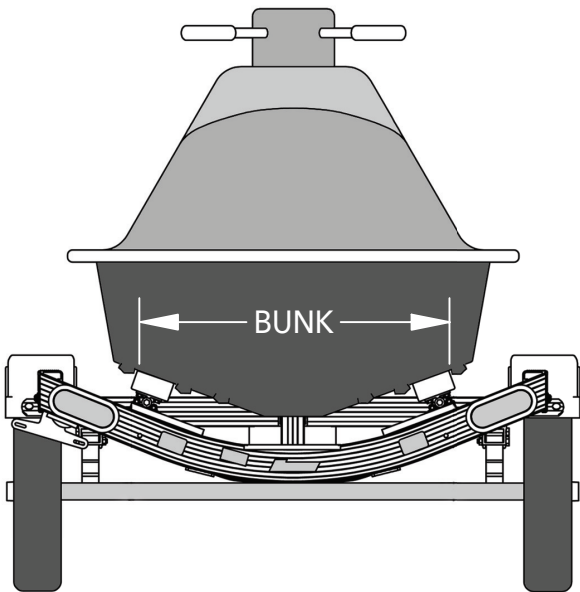

These measurements are meant to be a guide to setup a 2015 Triton LTWCI or two place models with the new ISA bow stop. This does not include the Wave model. These are approximate positions for the stated PWC's. Make sure that the position of the bunks are between the outer chines of the hull. PWC position on the trailer front to back should achieve a tongue weight of 7-10% of the total gross weight of the trailer package for the best towing experience. (gas+gear+PWC's+trailer weight=gross)