



Service Bulletin

101 East Seneca Bancroft, IA 50517	Bulletin #: SB000003	Date: December 7, 2015
Prepared by: Bob Mortenson	Phone # 515-885-2398	Page: 1

Subject:

Inform Aluma dealers and owners that 8605T, 8610T and 8612T trailers may have misaligned welds that may contribute to a failure of the trailer's axle mount weldment.

Solution: Repair misaligned welds and add flat straps to inside of axle mounts for additional support as shown below in service bulletin. Aluma will allow 1/2 hour of labor to be submitted for retrofit of trailer.

Models and VIN Numbers (if applicable) Affected:

- 8605T – Retrofit starting with VIN number 000305 – manufactured starting date January 1, 2011 ending October 2015
- 8610T – Retrofit starting with VIN number 000238 – manufactured starting date January 1, 2011 ending October 2015
- 8612T – Retrofit starting with VIN number 000281 – manufactured starting date January 1, 2011 ending October 2015

Retrofit kit: To be ordered from Aluma Service Department – at no charge

Quantity	Description
4	Flat Strap AL 3/16 x 1.5 x 2.0"- part number 14000-002-000

Note: The following part is required for update and do not substitute any of these parts.

Retrofit Instructions:

Warning: Use appropriate jack and jack stands, ensure weight ratings capacity exceed weight of trailer. Park trailer on hard level surface.

- 1.0 Using the jack raise and place trailer on the four jack stands. **Warning:** Never go under your trailer unless it is on firm level ground and resting on properly located rated secured jack stands.
- 2.0 Remove and secure tires and hardware to be reinstalled later in step 8.
- 3.0 Inspect inside weld joint of axle mounts and U-channels for misalignment of weld or any cracks in welds. See Figure 1. If any defects are present proceed to inspecting axle mount outside welds and verify that there are no signs of base material damage. Repair all suspect welds using step 6. See Figures 3 and 4.
- 4.0 Add flat strap to inside of axle mount as shown in Figure 1 and 2. Depending on condition of welds found in steps 5 or 6.
 - 4.1 Option 1: Flat strap must be located 2 inches from end of axle mount if flat strap can be placed flat onto axle mount and U-channel and then weld.
 - 4.2 Option 2: flat strap is to mount next to end of weld on axle mount bracket. Weld joint using a 1/4" butt weld.
- 5.0 For any misaligned welds prepare surface to be rewelded. All welds shall be centrally located in joints. This will provide weld leg length and groove weld to ensure joint penetration necessary for an acceptable weld. Weld joint using 1/4" butt weld at least 3 inches long.



Service Bulletin

101 East Seneca Bancroft, IA 50517	Bulletin #: SB000003	Date: December 7, 2015
Prepared by: Bob Mortenson	Phone # 515-885-2398	Page: 2

- 6.0 For any cracked or poor quality welds, grind cracked or poor quality weld and prepare any surrounding surface areas to be welded. Weld joint using 1/4" butt or fillet weld at least 3 inches long.
- 7.0 Person performing retrofit should be qualified and proficient aluminum welder. **Caution:** Use appropriate PPEs when preparing surface and welding. **Note:** Ensure that wiring harness is not damaged during welding.
- 8.0 Reinstall tires torque lug nuts to 110 ft/lbs. For more detailed information, refer to Aluma Owner's manual.
- 9.0 Verify work has been completed and all tools and hardware is secured. Raise trailer and remove jack stands.
- 10.0 Lower trailer and perform driving functional test to verify trailer is traveling correctly.
- 11.0 For more detailed information, always refer to Aluma Owner's Manual.



Figure 1

Option 1: flat strap configuration.
Inspect location of weld in joint.



Service Bulletin

101 East Seneca Bancroft, IA 50517

Bulletin #: SB000003

Date: December 7, 2015

Prepared by: Bob Mortenson

Phone # 515-885-2398

Page: 3

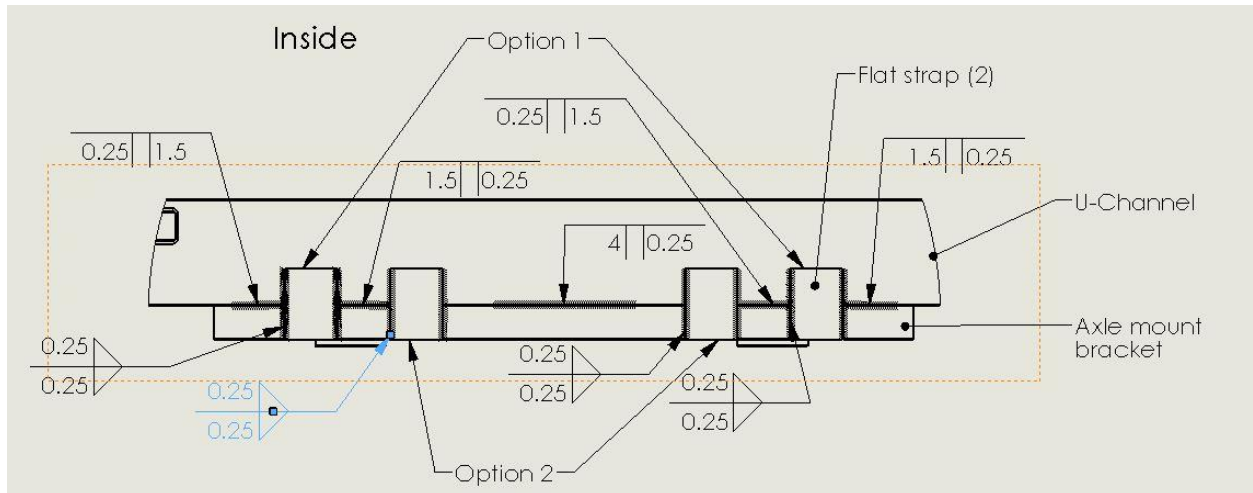

Figure 2

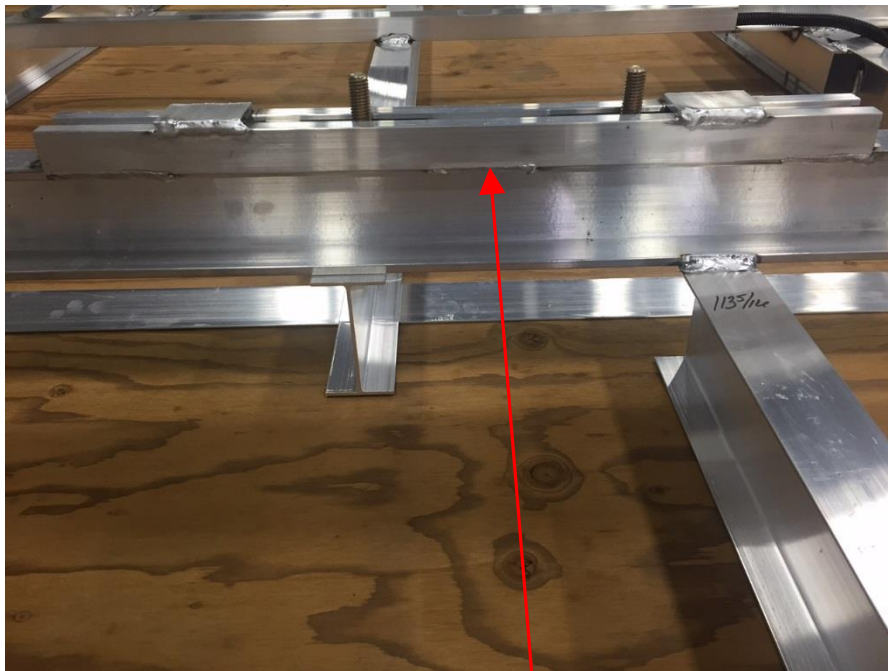

Figure 3

Outside axle mount: inspect for poor quality welds.



Service Bulletin

101 East Seneca Bancroft, IA 50517	Bulletin #: SB000003	Date: December 7, 2015
Prepared by: Bob Mortenson	Phone # 515-885-2398	Page: 4

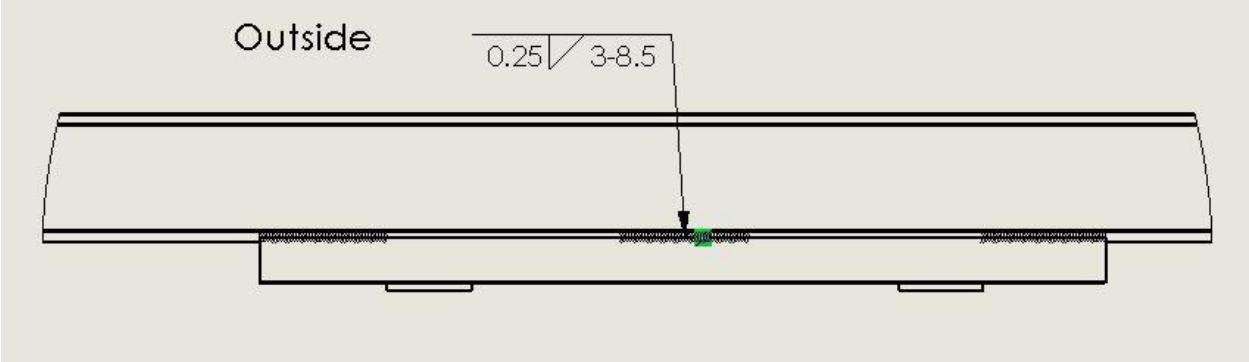

Figure 4