

IMPORTANT SAFETY RECALL NOTICE



565 de la Montagne Street
Valcourt, Québec, Canada J0E 2L0
T 450.532.2211 F 450.532.5133

www.brp.com

May 26, 2015

Re: Can-Am® Spyder® Roadster RT™ 2013 – Elevated Temperature in Engine Compartment

Dear Can-Am roadster Dealer,

This notice is being sent to you following the interim notice sent in February 2015, in accordance with the requirements of the National Traffic Motor Vehicle and Canada Motor Vehicle Safety Acts. BRP has decided that a defect which relates to motor vehicle safety exists on certain Can-Am roadster models and is conducting a safety recall. The remedy is now available.

What is the potential problem?

Under very hot ambient conditions and low speed riding, the temperature in the engine compartment may rise and thereby increase the risk of a skin burn or a vehicle fire.

Which models are involved?

Can-Am Spyder RT roadster, model year 2013.

What will BRP do?

BRP intends to repair involved vehicles, free of charge for the customer.

For dealers: BRP is publishing a Safety Campaign Bulletin describing procedures to install improved body panels and an upgraded fuel system kit.

For customers: BRP is sending to all known registered owners a Safety Recall letter. This letter urges owners to immediately contact their authorized BRP dealer in order to have their vehicle repaired.

Also, BRP is posting this notice on its dealer website BOSSWeb (www.bossweb.brp.com). Information for customers is posted on BRP's public website (www.can-am.brp.com).

What should you do?

- Do not sell or deliver any involved vehicle that you have in stock as federal law requires you to complete the recall service on these vehicles before retail delivery.
- Contact all of your customers who have purchased an affected Can-Am Spyder roadster. You must inform them about the foregoing and must request them to make an appointment to get their vehicle repaired.
- Follow all instructions provided in the attached Safety Campaign Bulletin.
- Inform any owner that cannot get his vehicle repaired immediately that, although BRP insist to get all involved vehicles repaired rapidly, they can keep using their vehicle while taking the following precautions in hot riding conditions (ambient temperature of approximately 30 C/85 F and more):
 - Avoid idling or slow traffic riding for a long period of time.
 - Avoid parking in an enclosed area immediately after a ride, let vehicle cool down first.
 - Avoid prolonged direct contact with body panels; wear appropriate riding gear as stated in the Operator's Guide.

Ski-Doo
Lynx
Sea-Doo
Evinrude
Rotax
Can-Am

Please note that the National Traffic and Motor Vehicle Safety Act provides that each vehicle which is subject to a recall campaign of this type must be adequately repaired within a reasonable time after the owner has tendered it for repair. Failure to repair within sixty (60) days after tender of a vehicle is prima facie evidence of failure to repair within a reasonable time. The owner may be entitled to an identical or reasonable equivalent vehicle at no charge or to a refund of the purchase price less a reasonable allowance for depreciation.

If you have questions about this notice, please communicate with us:

- By submitting a **BOSSWeb case**. A service representative will communicate with you.
- OR**
- In USA and Canada: [1-800-366-6992](tel:1-800-366-6992)
Eastern time Monday to Friday from 10:00 AM to 5:00 PM

Thank you for your immediate attention to this matter.

Sincerely,
After-Sales Service Department



WARRANTY BULLETIN SAFETY CAMPAIGN

⚠ WARNING: All involved customers must be notified, all involved units must be corrected as per instruction herein.

Campaign no.: 2013-0017

May 26, 2015

Subject: **Elevated Temperature in Engine
Compartment**

No. **2013-10**

YEAR	MODEL	MODEL NUMBER	SERIAL NUMBER
2013	Spyder RT Series	All	All

TABLE OF CONTENTS

	Page		Page
PROBLEM	1	Preparing the Vehicle	4
SOLUTION	1	Drilling the RH Under Panel.....	8
BRP PAC ACCESSORIES	2	Replacing the Fuel and Evaporative System Components.....	9
SERVICE TOOLS	2	Reassembling the Vehicle.....	15
REQUIRED PARTS	2	Adding Air Intake Scoops to Top Side Panels	18
ICON LEGEND	2	Updating the ECM.....	22
PANEL NOMENCLATURE	3	WARRANTY	25
INSTRUCTIONS	4	DRILLING TEMPLATE	27

PROBLEM

Under very hot ambient conditions and low speed riding, the temperature in the engine compartment may rise and thereby increase the risk of a skin burn or a vehicle fire.

SOLUTION

Install improved body panels and an upgraded fuel system kit.

Update the ECM **after the repair**.

BRP PAC ACCESSORIES

The following BRP PAC accessories are no longer compatible with the improved body panels and can no longer be installed on repaired vehicles.

DESCRIPTION	PART NUMBER
Fixed upper wind deflector (chrome)	219 400 290
Adjustable side wind deflector (clear)	219 400 362
Adjustable side wind deflector (chrome)	219 400 413

SERVICE TOOLS

North American Dealers

Please note that BRP will auto-ship these tools, at no cost, to every dealer who has at least one impacted VIN.

International Dealers and Distributors

Please contact your local BRP After Sales representative.

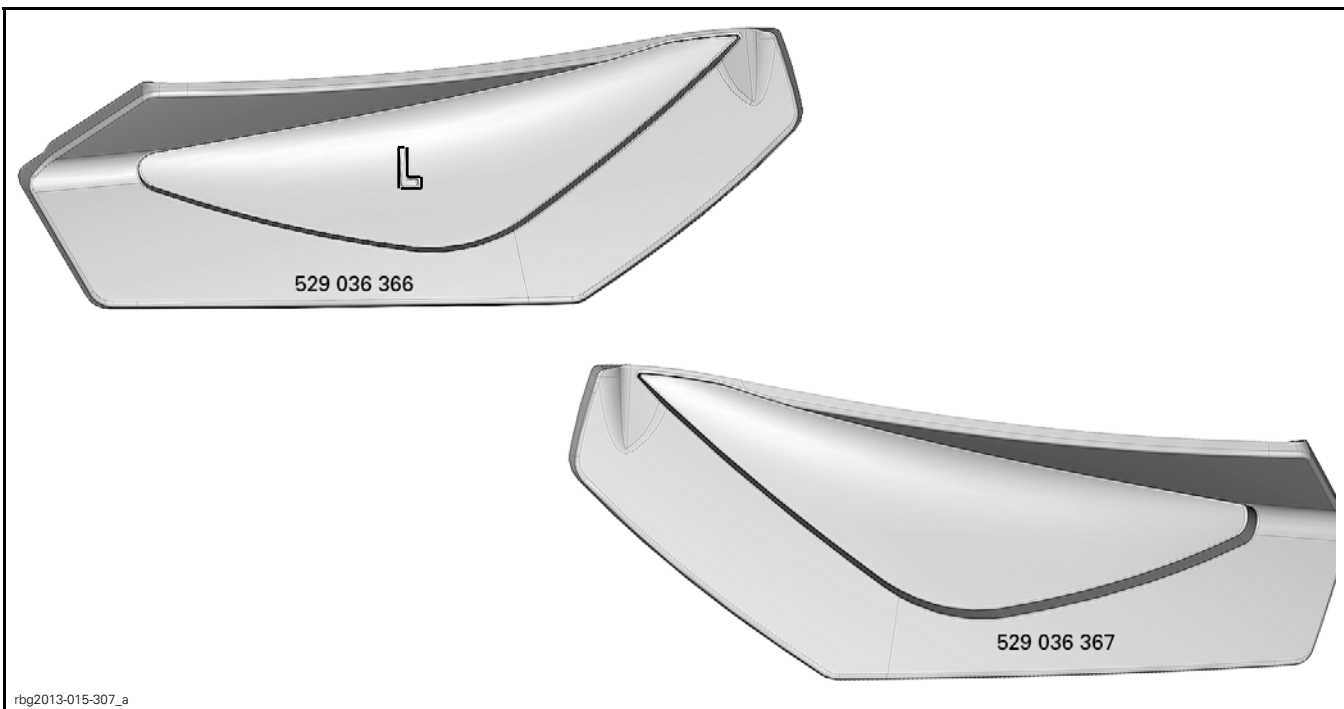

DESCRIPTION	PART NUMBER	QUANTITY
LH top side panel cutting jig	529 036 366	1
RH top side panel cutting jig	529 036 367	1

REQUIRED PARTS

DESCRIPTION	PART NUMBER	QTY
Heat management kit	219 800 371	1

ICON LEGEND

ICON	INDICATES
	Parts to be discarded

PANEL NOMENCLATURE

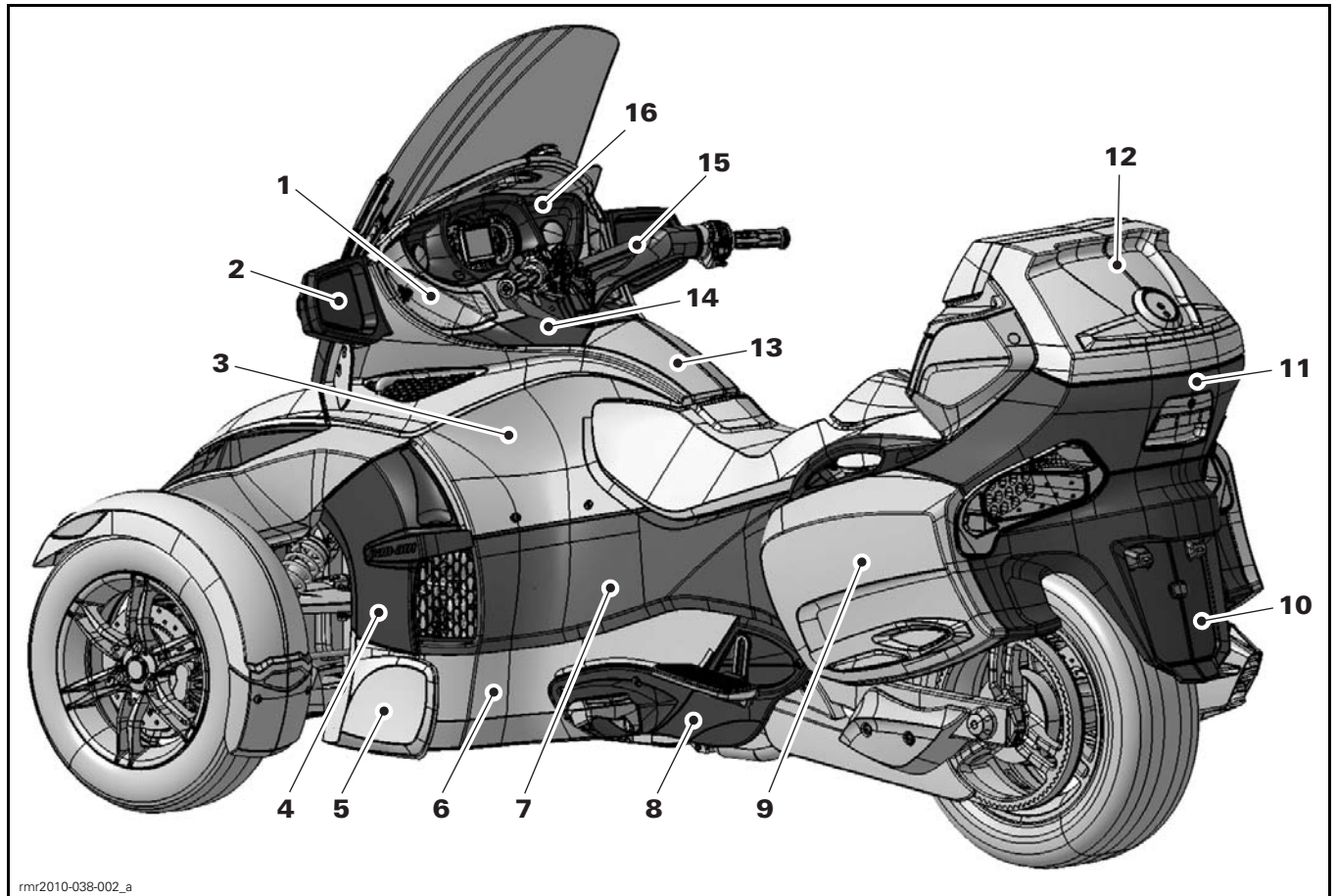

rmr2010-038-002_a

1. Front speaker grille (option package)
2. Mirror
3. Top side panel
4. Middle side panel
5. Bottom front side panel
6. Bottom rear side panel
7. Rear side panel
8. Footrest support
9. Side storage compartment cover
10. Rear fender
11. Rear panel
12. Top storage compartment cover
13. Glove box
14. Central panel
15. Ignition switch cover
16. Gauge trim

INSTRUCTIONS

HELP VIDEO

A help video is available on the *KNOWLEDGE CENTER*. Refer to article: **112165**

Refer to *SHOP MANUAL* for procedures when available.

Preparing the Vehicle

IMPORTANT

Do not update the ECM at this point; update must be done at the end of procedure

1. Remove LH and RH mirrors.



2. Remove and discard LH and RH lateral air deflectors.



3. Remove LH and RH middle side panels.



4. Open front storage compartment cover, remove LH and RH service panels.

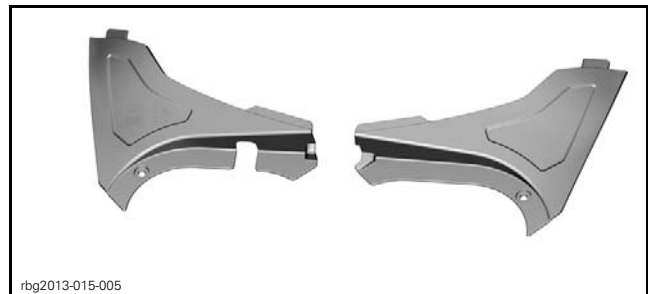

5. Remove LH and RH top side panels.

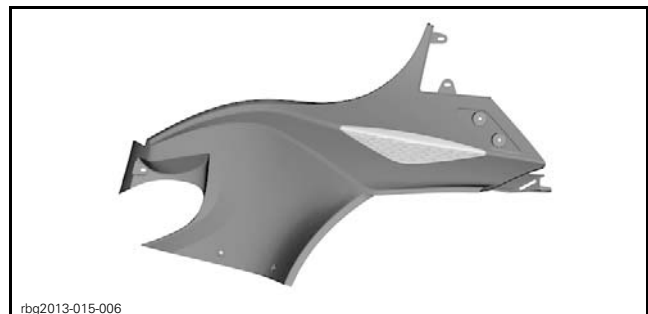

6. Open RH side storage compartment cover.

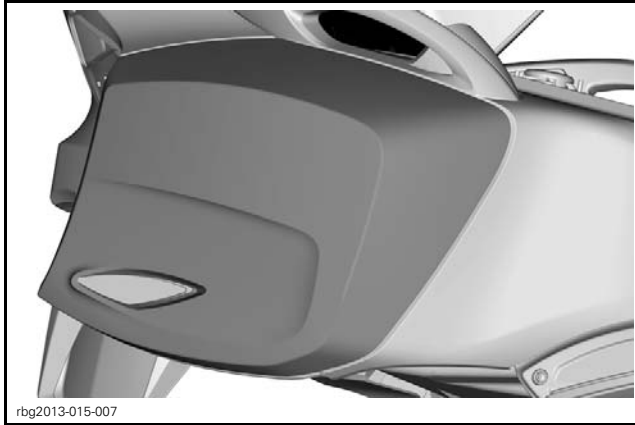

7. Remove RH rear side panel.



8. Remove and discard LH and RH acoustic panels.

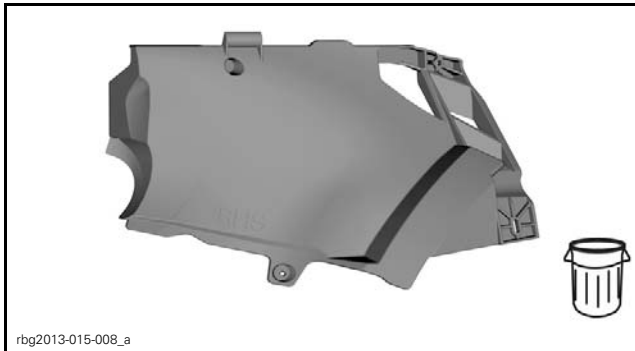

9. Remove RH bottom front side panel.



10. Remove RH bottom rear side panel.

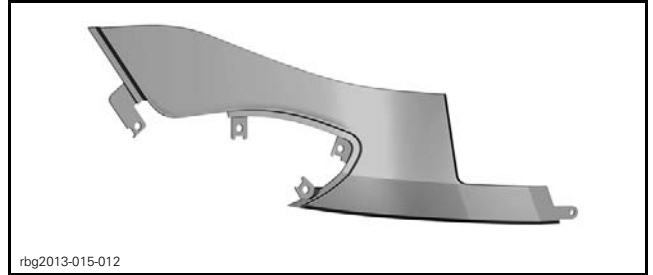

11. Remove RH body support.



12. Remove glove box retaining screws.

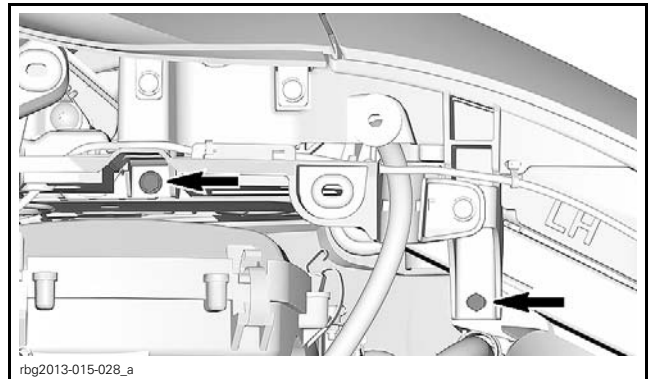

13. Remove LH and RH tank covers.

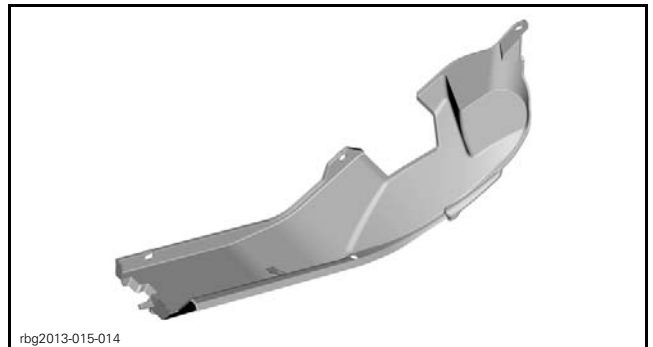

14. Remove seat latch bracket 2 screws and nuts just over fuel pump;

14.1 Discard nylon nuts.

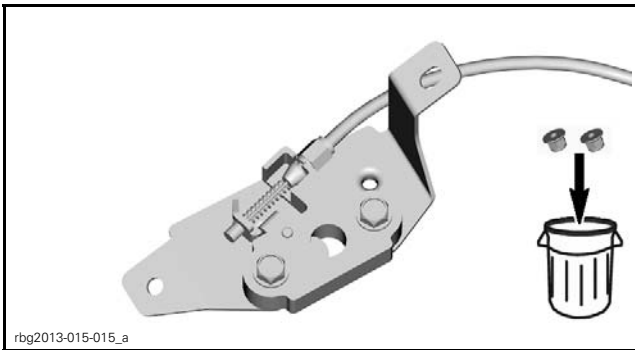

15. Remove 2 rear screws of RH frame lateral support;

15.1 Discard screws.

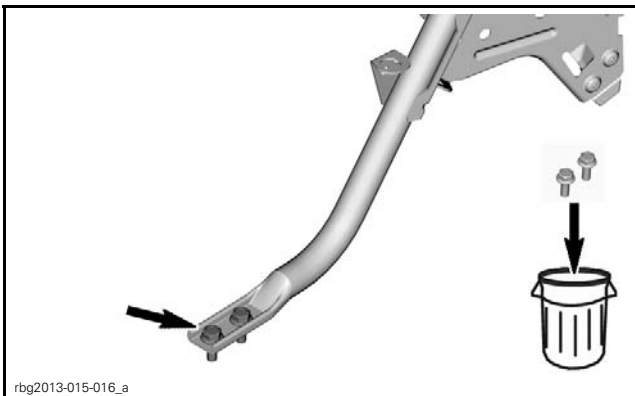

16. Remove front RH fuel tank screw and nut;

16.1 Discard screw and nylon nut.

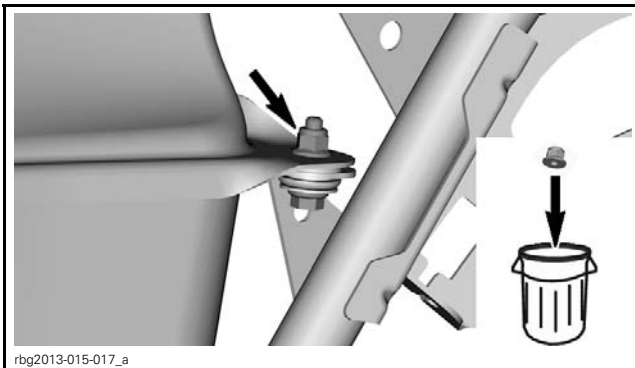

17. Insert a tool to give extra clearance to access canister assembly.



18. Disconnect fuel pump connector.

19. Crank engine to release fuel pressure in the fuel pump pressure hose.

20. Disconnect battery.

21. Remove glove box assembly with console switches;

21.1 Disconnect console switch harness connector (LH);

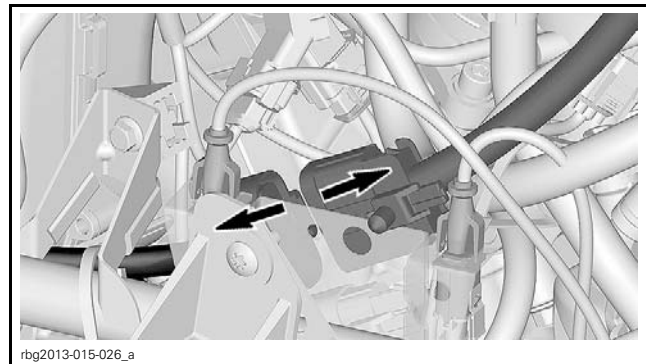

21.2 Remove glove box locking cable;

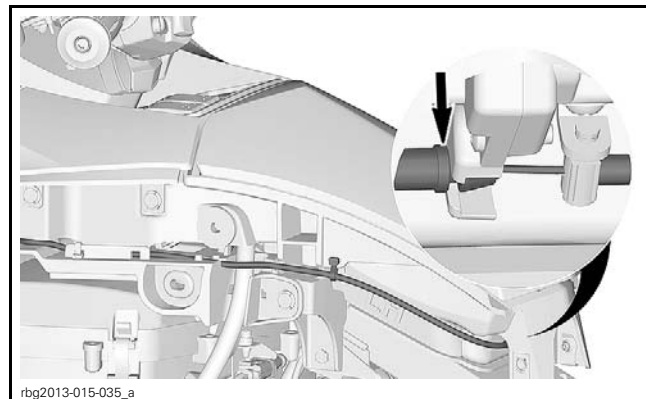

21.3 Remove locking ties;

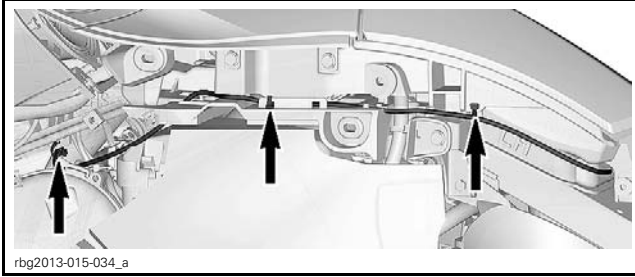

21.4 Remove glove box assembly with console switches.

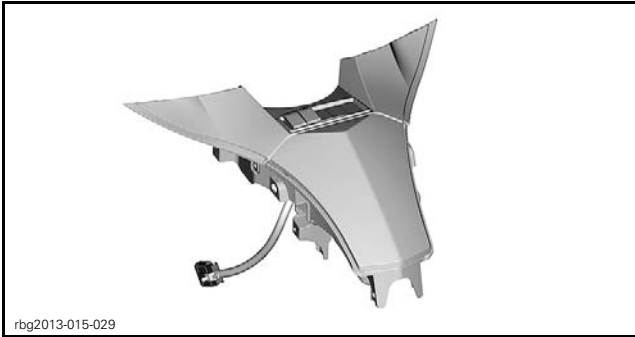

22. Remove front fascia.

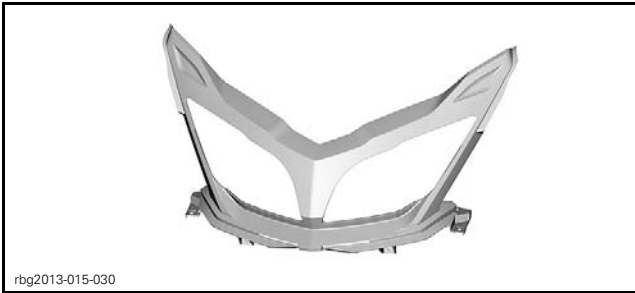

23. Remove console module assembly.

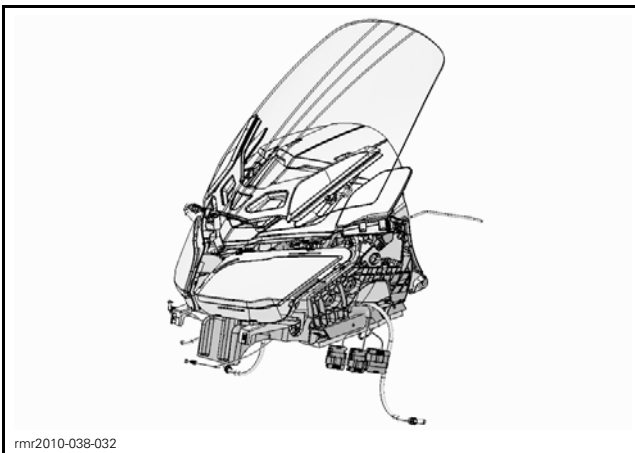

24. Remove air filter cover;

24.1 Loosen air intake hose clamp.

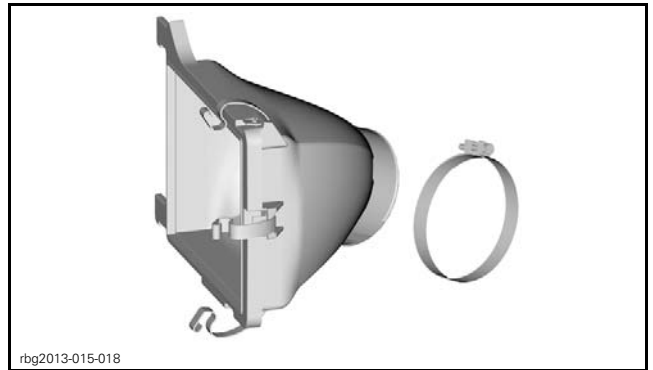

25. Cut locking ties securing harnesses to the air box.

26. Remove air box cover.

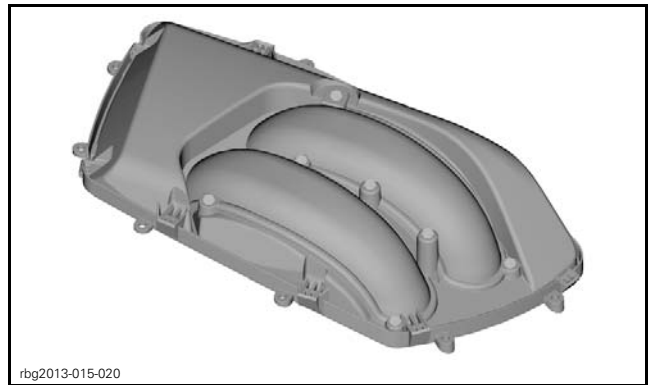

27. Cut Oetiker clamp and remove breather hose from air box.

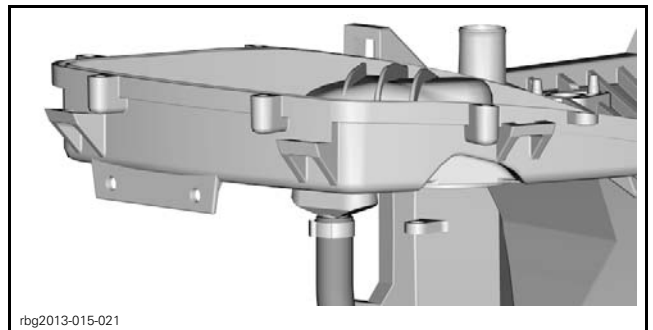

28. Remove and discard screws securing air box to throttle body.

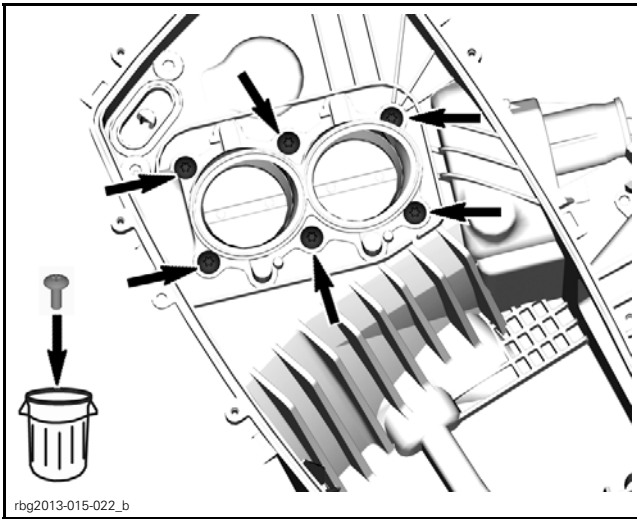

29. Remove the RH center acoustic shell.

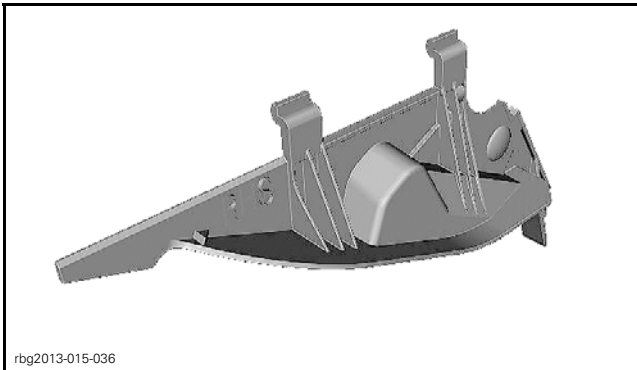

30. Remove air box by sliding it out on the RH side.

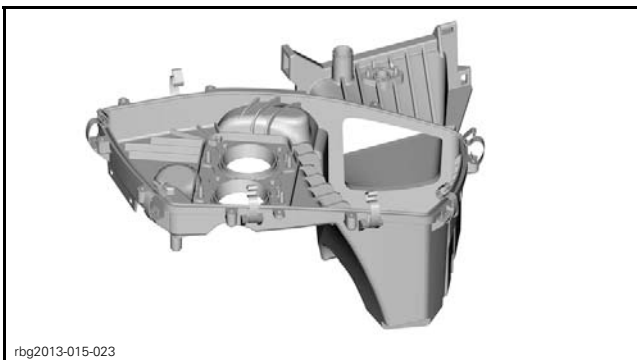

31. Cover the throttle body openings to prevent dust or foreign objects getting into the engine.

Drilling the RH Under Panel

REQUIRED ITEMS		
ITEM	DESCRIPTION	QUANTITY
P1	Drilling template (last page of bulletin)	1
	7.94 mm (5/16 in) drill bit	1

1. Remove RH under panel.

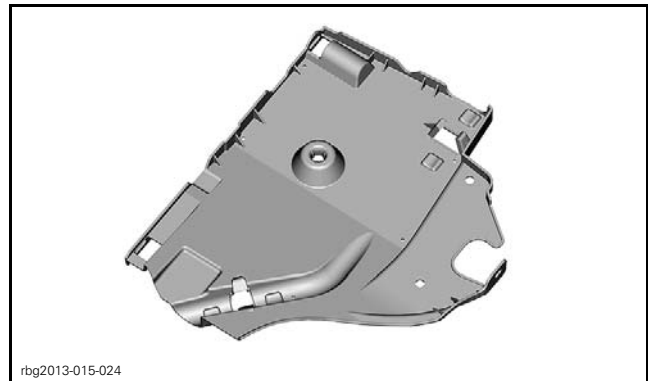

2. Using the template [P1] drill RH under panel.

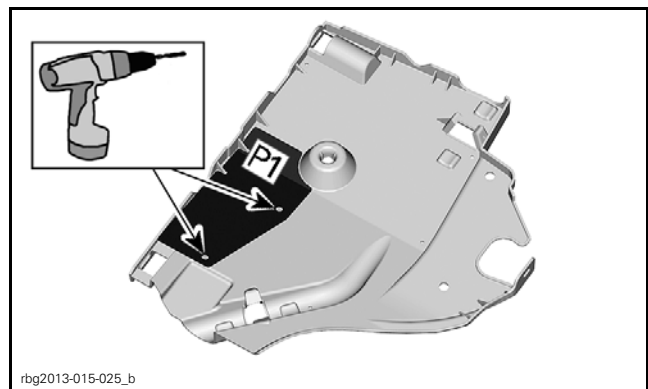

3. Reinstall under panel.

Replacing the Fuel and Evaporative System Components

Removing Existing Evaporative System Components

Use a rag and be prepared for fuel to spill out of hoses.

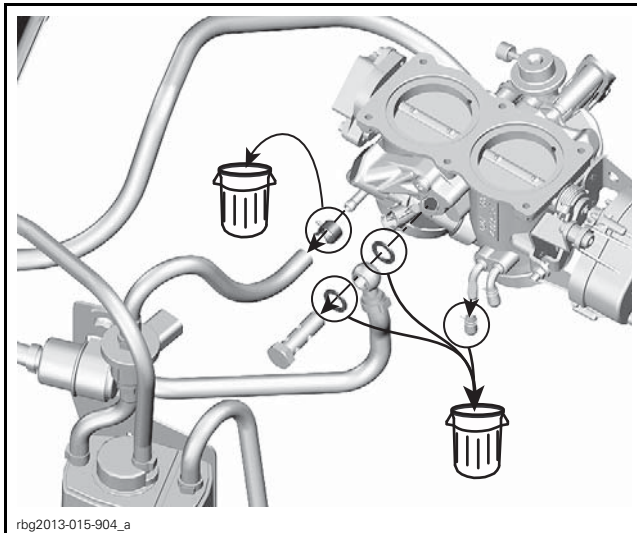
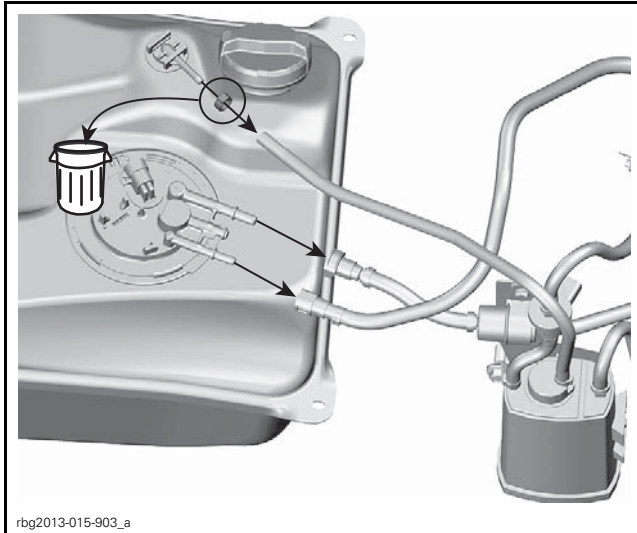

NON-CARB VEHICLES

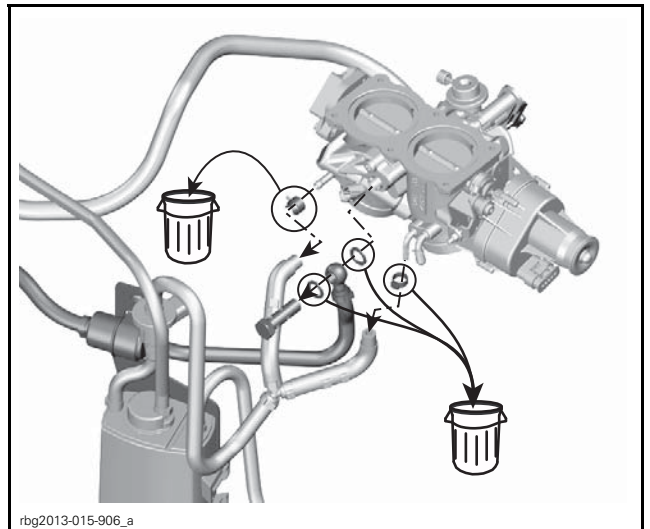

CARB VEHICLES

1. Remove canister from support.
2. Keep support screws.

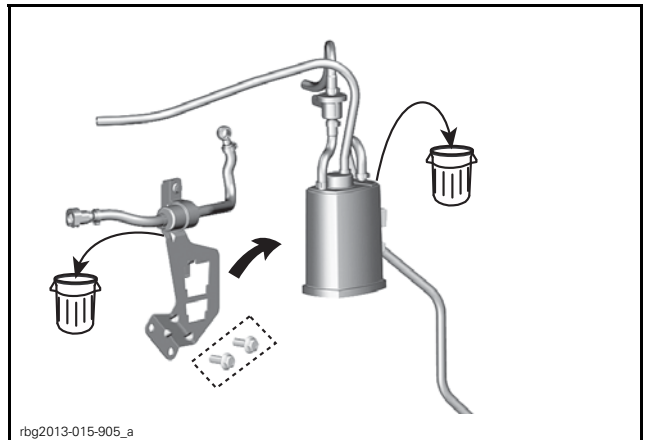

KEEP SCREWS INSIDE DOTTED LINES

Replacing the Fuel Pressure Regulator

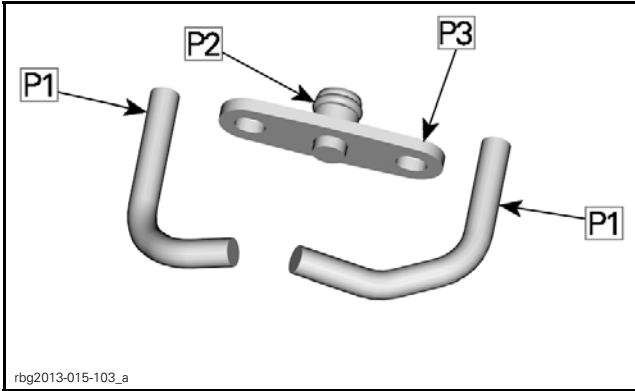

rbg2013-015-103_a

REQUIRED ITEMS

ITEM	DESCRIPTION	QUANTITY
P1	MAPS hoses	2
P2	O-ring	1
P3	Fuel pressure regulator plug	1

1. Remove and discard fuel pressure regulator and return line;

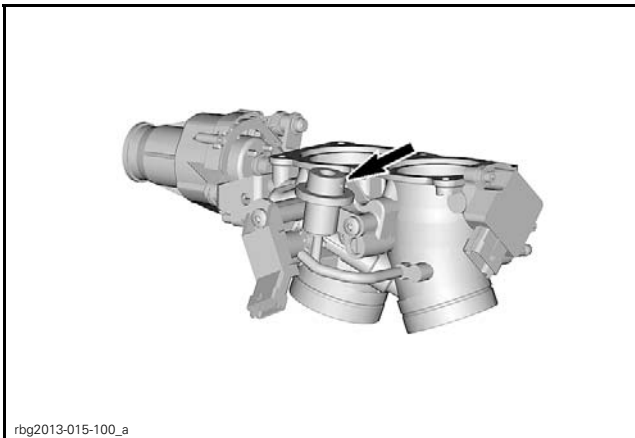

rbg2013-015-100_a

- 1.1 Keep the screws and lock washers.



rbg2013-015-104_a

2. Discard the return line clip under the top frame member.



rbg2013-015-102

3. Remove and discard MAPS hoses.

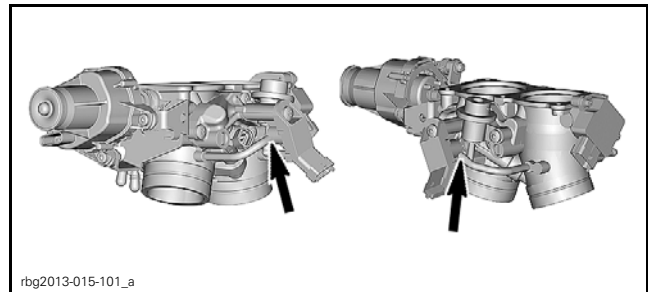

rbg2013-015-101_a

4. Close throttle plate bypass screws.

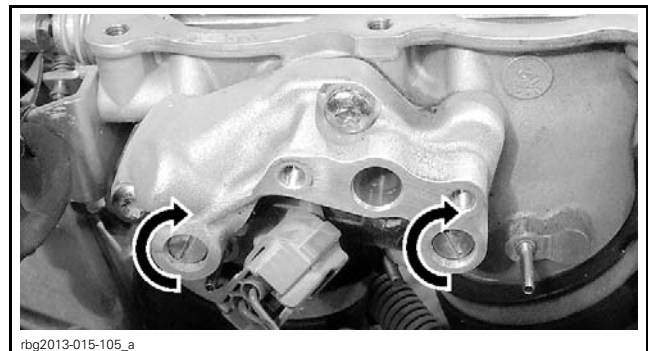

rbg2013-015-105_a

TIGHTENING TORQUE

Throttle plate bypass screws	1.5 N•m ± 0.2 N•m (13 lbf•in ± 2 lbf•in)
------------------------------	---

5. Lubricate O-ring [P2] with **SAE 30** engine oil.
6. Install fuel pressure regulator plug [P3].
7. Install new MAPS hoses [P1] on MAPS.
8. Re-install the MAPS.

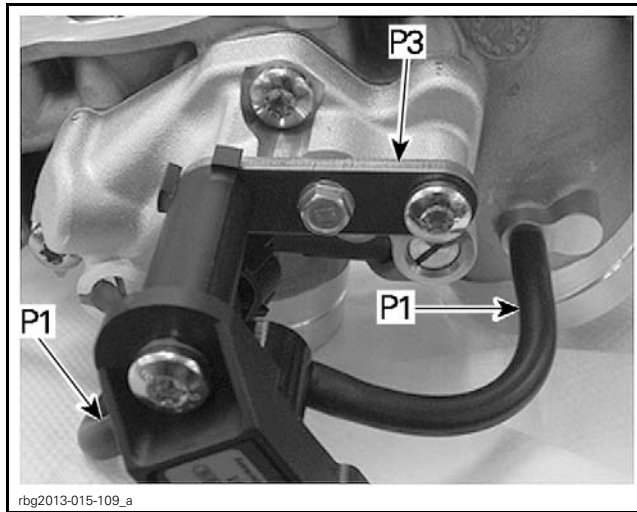

TIGHTENING TORQUE	
Fuel pressure regulator plug screws	3.5 N•m ± 0.2 N•m (31 lbf•in ± 2 lbf•in)

Installing the New Evaporative System Components

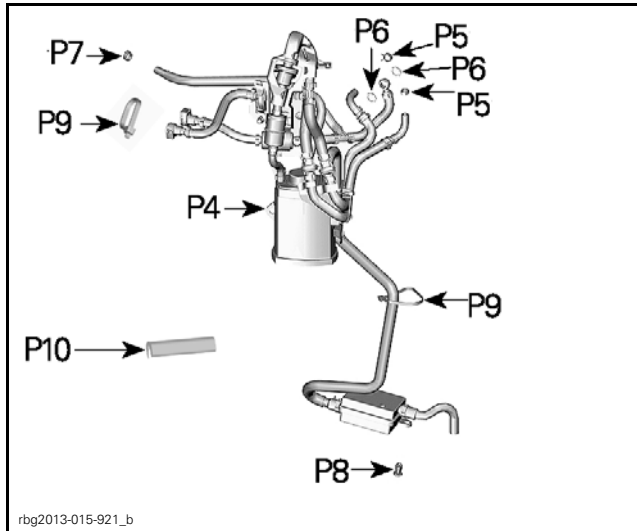

REQUIRED ITEMS		
ITEM	DESCRIPTION	QUANTITY
P4	Canister	1
P5	Spring clamp	2
P6	Sealing washer	2
P7	Oetiker clamp	1

REQUIRED ITEMS		
ITEM	DESCRIPTION	QUANTITY
P8	Plastic rivet	2
P9	Long locking tie	2
P10	Protector	1

1. Unclip the canister [P4] from its support.
2. Insert the canister and hose assembly between engine and RH frame lateral support.



3. Secure the canister support to engine using previously removed M10 screws.

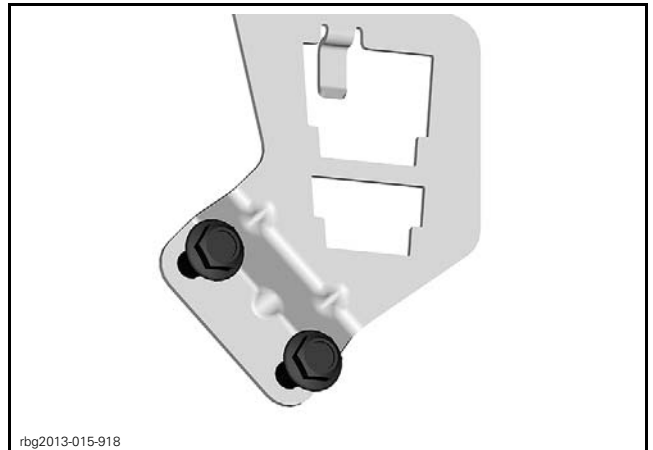

TIGHTENING TORQUE	
Canister support screws	29 N•m ± 3 N•m (21 lbf•ft ± 2 lbf•ft)

4. Root the canister vent hose down between engine and thermostat.

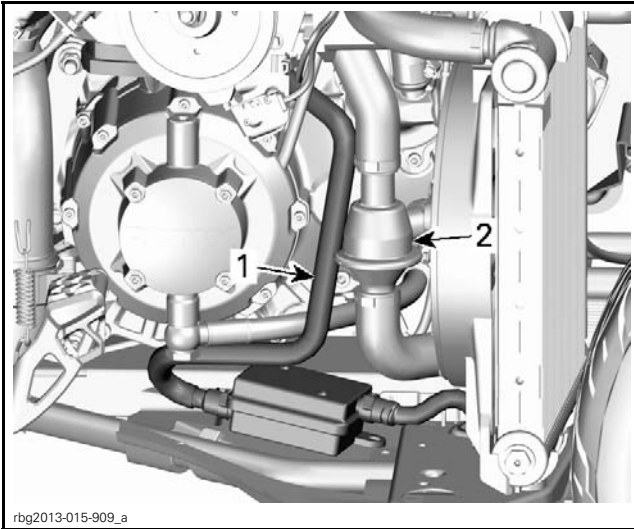

SE5 MODELS
 1. Canister vent hose
 2. Thermostat



SM5 MODELS

5. Install the canister on its support:
- Ensure vent hose is contained by plastic support clip
 - Approach canister by making sure the vent hose goes behind the canister support.
 - Insert both tabs of canister into the canister support slots.
 - Push the canister down until it clips.

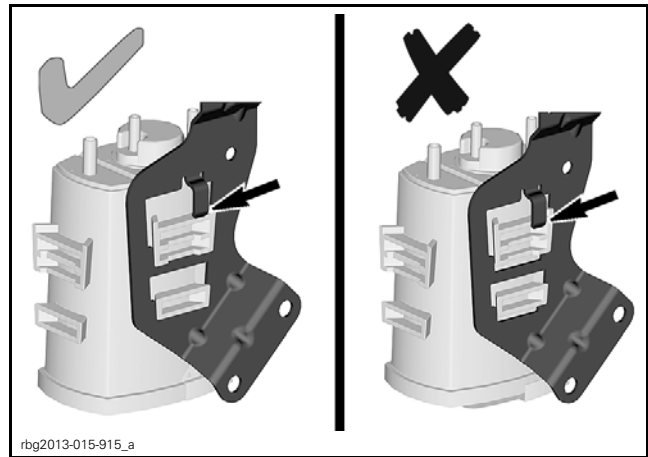

6. Remove white plastic protector tape from:

- The 2 purge lines
- The Banjo connector.

7. Clean the previously removed Banjo bolt with PULLEY FLANGE CLEANER (P/N 413 711 809) or an equivalent.

8. Connect both purge lines to throttle body using spring clamps [P5].

9. Install the fuel pressure line using Banjo bolt and new sealing washers [P6].

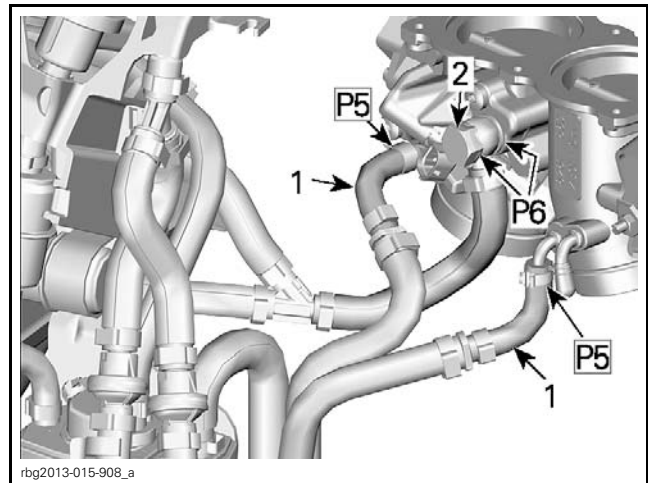

1. Purge lines over fuel hose
 2. Previously removed Banjo bolt

TIGHTENING TORQUE	
Banjo bolt	23 N•m ± 1 N•m (17 lbf•ft ± 1 lbf•ft)

10. Remove white plastic protector tape from pressure and return lines.

11. Lubricate the exterior of the fuel pump fittings with **SAE 30** engine oil.

12. First, connect the fuel pressure line to fuel pump then the return line.

NOTE: The return line must cross above the pressure line.

13. Remove white plastic protector tape from the roll over vent hose.
14. Secure the hose using new Oetiker clamp [P7].

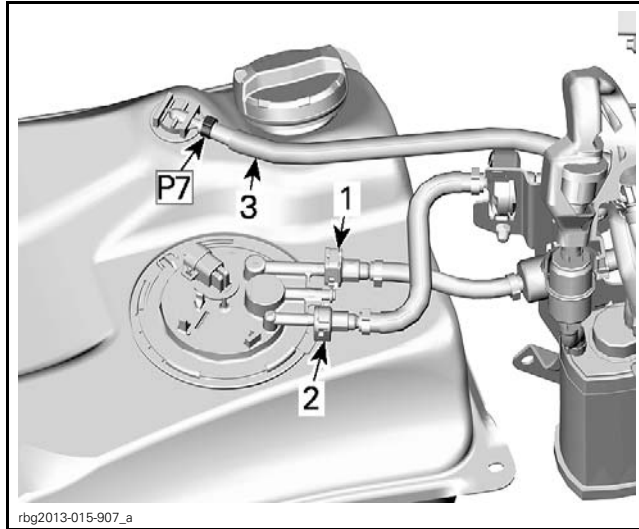

1. Fuel pressure line
2. Fuel return line
3. Roll over vent hose

15. Connect fuel pump connector.
16. Secure fuel pump harness to pressure hose with a locking tie [P9].

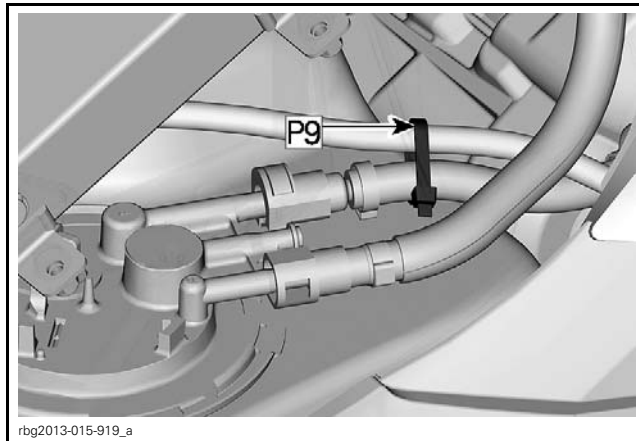

17. Connect purge valve electrical connector, route harness over hoses.



18. Remove white plastic protector tape from the end of the canister vent hose.
19. Install the canister vent hose end into the embossed hole of the RH under panel

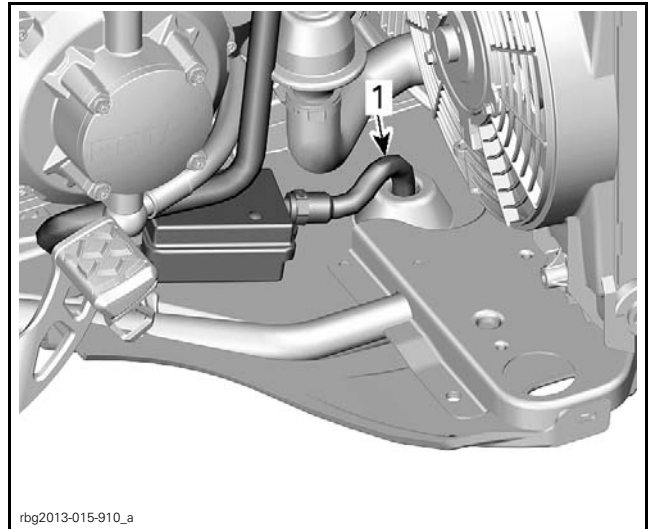

1. Canister vent hose

20. Secure the pre-filter using plastic rivets (2x) [P8].

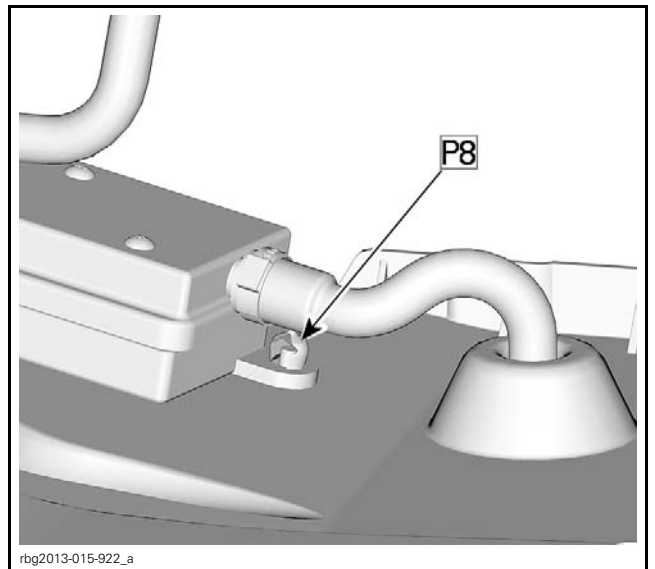

21. Secure the canister vent hose to thermostat cooling hose using a new locking tie [P9].

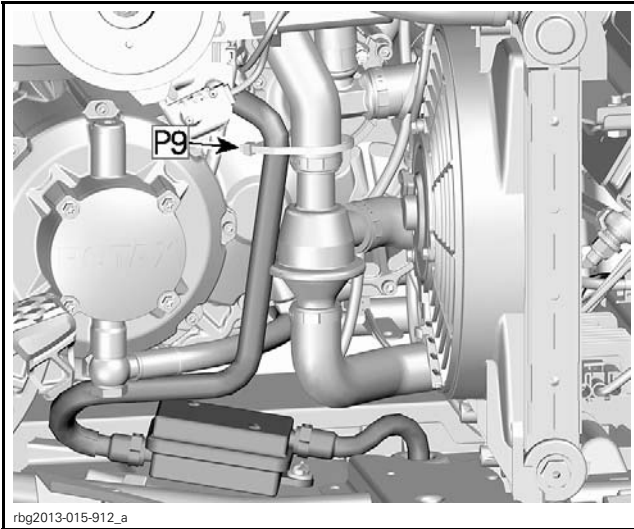

22. Install protector [P10] on RH frame lateral support under connector.

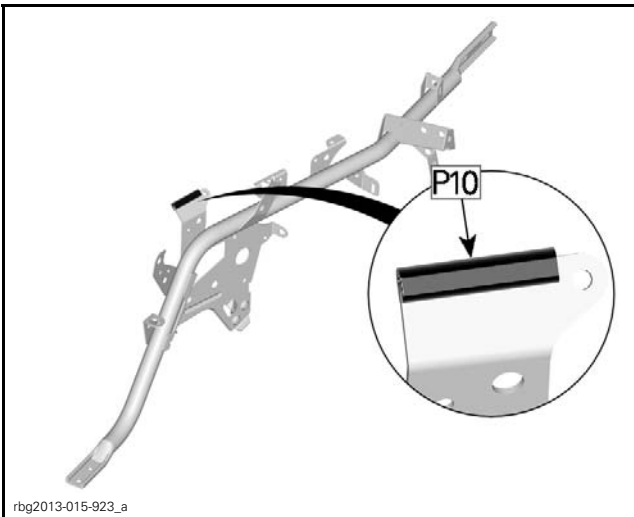

- 23. Connect battery and turn key on.
- 24. Make sure fuel pump turns on.
- 25. Turn key off.
- 26. Check for leaks, repair as necessary then proceed to *REASSEMBLING THE VEHICLE*.

Reassembling the Vehicle

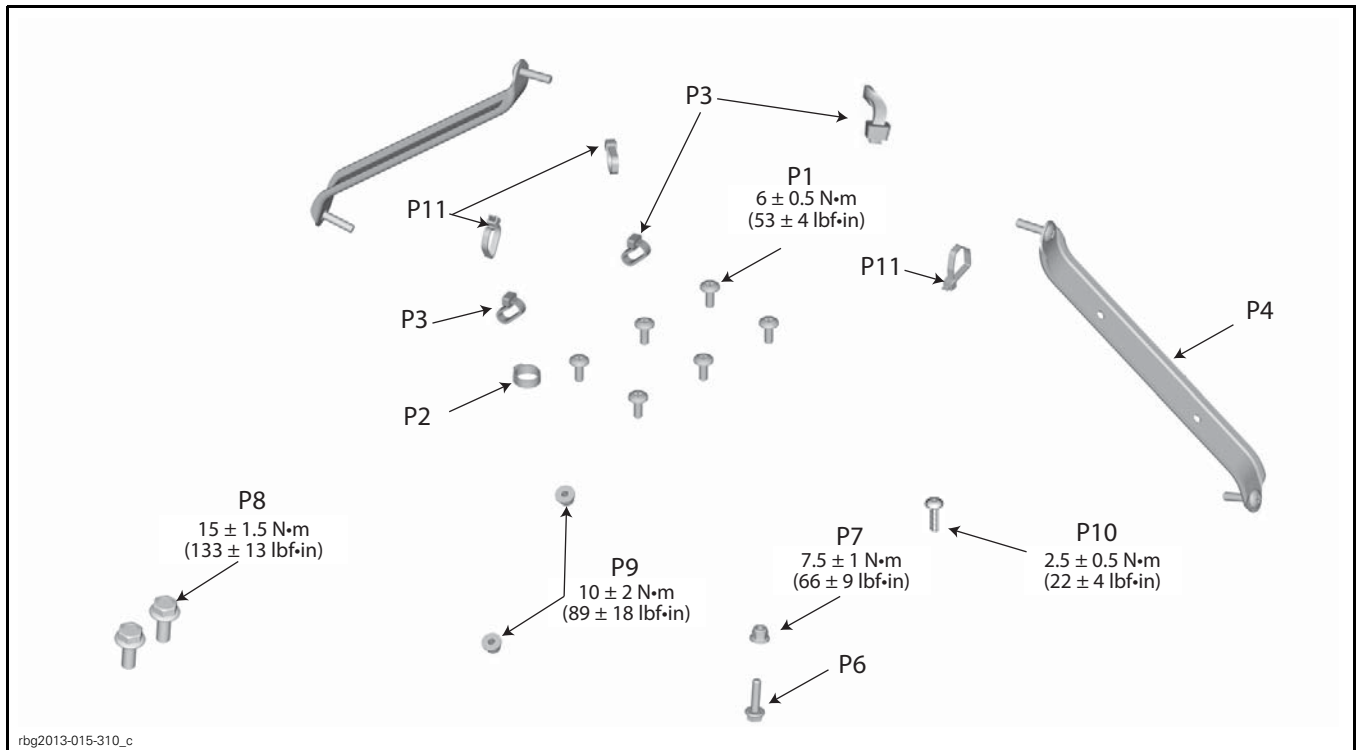

REQUIRED ITEMS		
ITEM	DESCRIPTION	QUANTITY
P1	Lower air box to throttle body screws	6
P2	Oetiker clamp	1
P3	Short locking tie (for glove box cable)	3
P4	Console support brackets	2
P6	Fuel tank screw	1
P7	Fuel tank nut	1
P8	RH frame lateral support screws	2
P9	Seat latch bracket nuts	2
P10	Torx screw	1
P11	Long locking tie (for harness routing around air box)	3

1. Install lower air box;
 - 1.1 Use new lower air box to throttle body screws [P1];
 - 1.2 Follow the torque sequence.

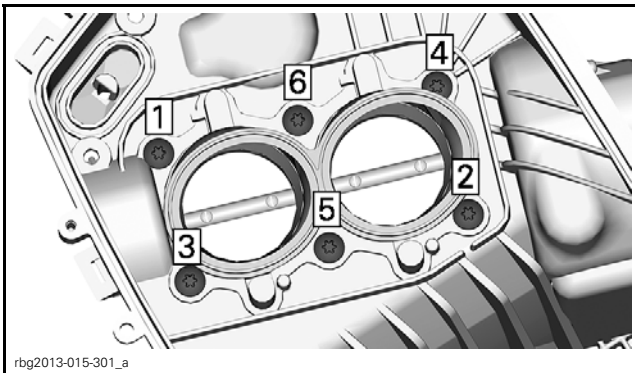

rbg2013-015-301_a

TIGHTENING TORQUE	
Throttle body screws [P1]	6 N•m ± 0.5 N•m (53 lbf•in ± 4 lbf•in)

2. Install breather hose on air box, secure with Oetiker clamp [P2].

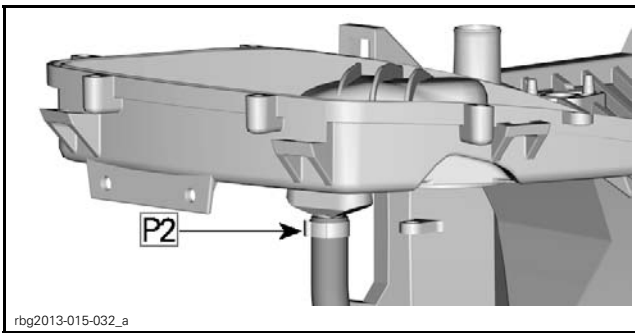

rbg2013-015-032_a

3. Install air box cover.
4. Route harness around air box.
5. Install air filter cover.
 - 5.1 Tighten air intake hose clamp.

TIGHTENING TORQUE	
Air intake hose clamp	2 N•m ± 0.5 N•m (18 lbf•in ± 4 lbf•in)

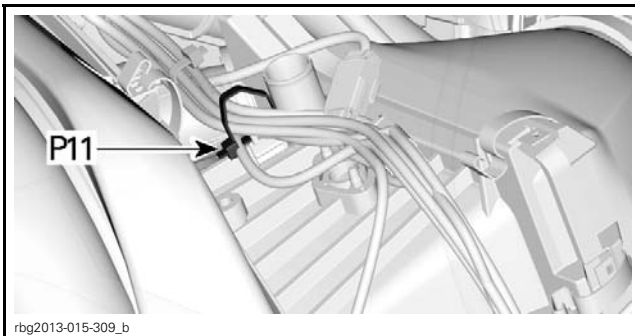

rbg2013-015-309_b

6. Install screw [P10] securing evaporative assembly to air box assembly.

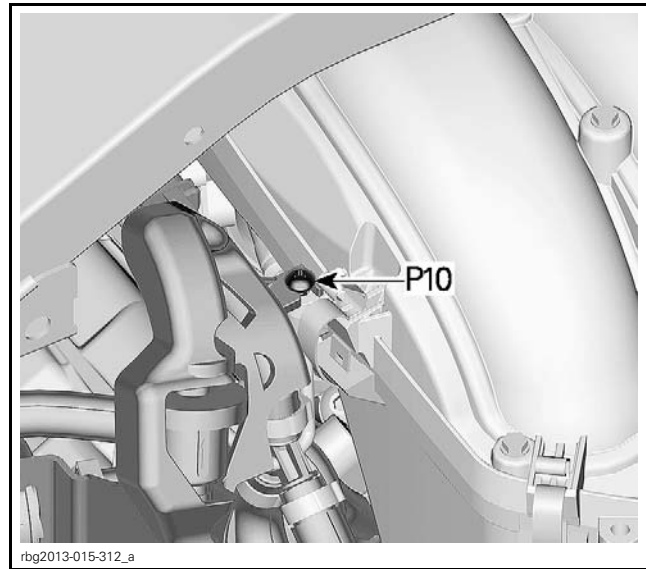

rbg2013-015-312_a

7. Install frame lateral support with new screws [P8].
8. Install new fuel tank screw [P6] and nut [P7].
9. Install seat latch with new nuts [P9]
10. Install the RH center acoustic shell.
11. Install console module and console switch harness connector.

TIGHTENING TORQUE	
Console module retaining screws	4.5 N•m ± 0.5 N•m (40 lbf•in ± 4 lbf•in)

12. Install front fascia.

TIGHTENING TORQUE	
Front fascia retaining screws	3.5 N•m ± 0.5 N•m (31 lbf•in ± 4 lbf•in)

13. Install glove box, cable, console switches, and new locking ties [P3].

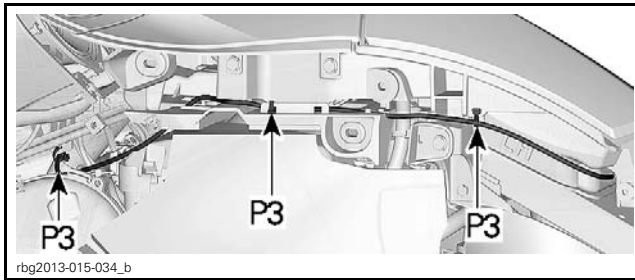

TIGHTENING TORQUE	
Glove box retaining screws	4.5 N•m ± 0.5 N•m (40 lbf•in ± 4 lbf•in)

14. Install the RH body support.

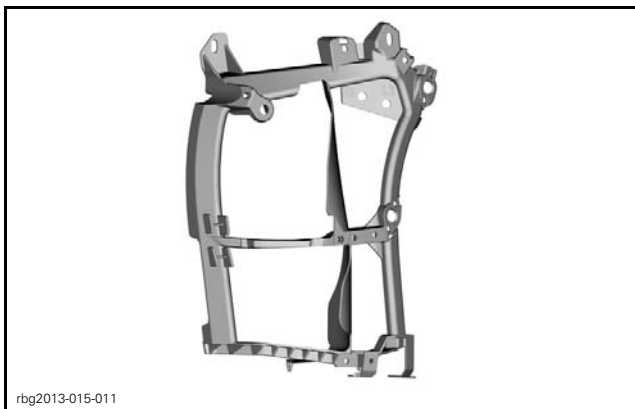

15. Install console support bracket [P4], secure with previously removed screws.

TIGHTENING TORQUE	
Console support bracket retaining screws	6 N•m ± 1 N•m (53 lbf•in ± 9 lbf•in)

NOTE: 'B' on bracket indicates the bottom. Install both brackets and screws before tightening.

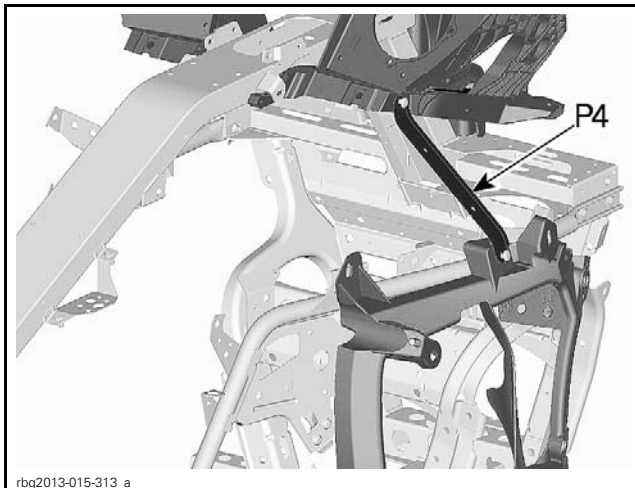

16. Install all remaining body panels. **Stop at top side panels.**

Adding Air Intake Scoops to Top Side Panels

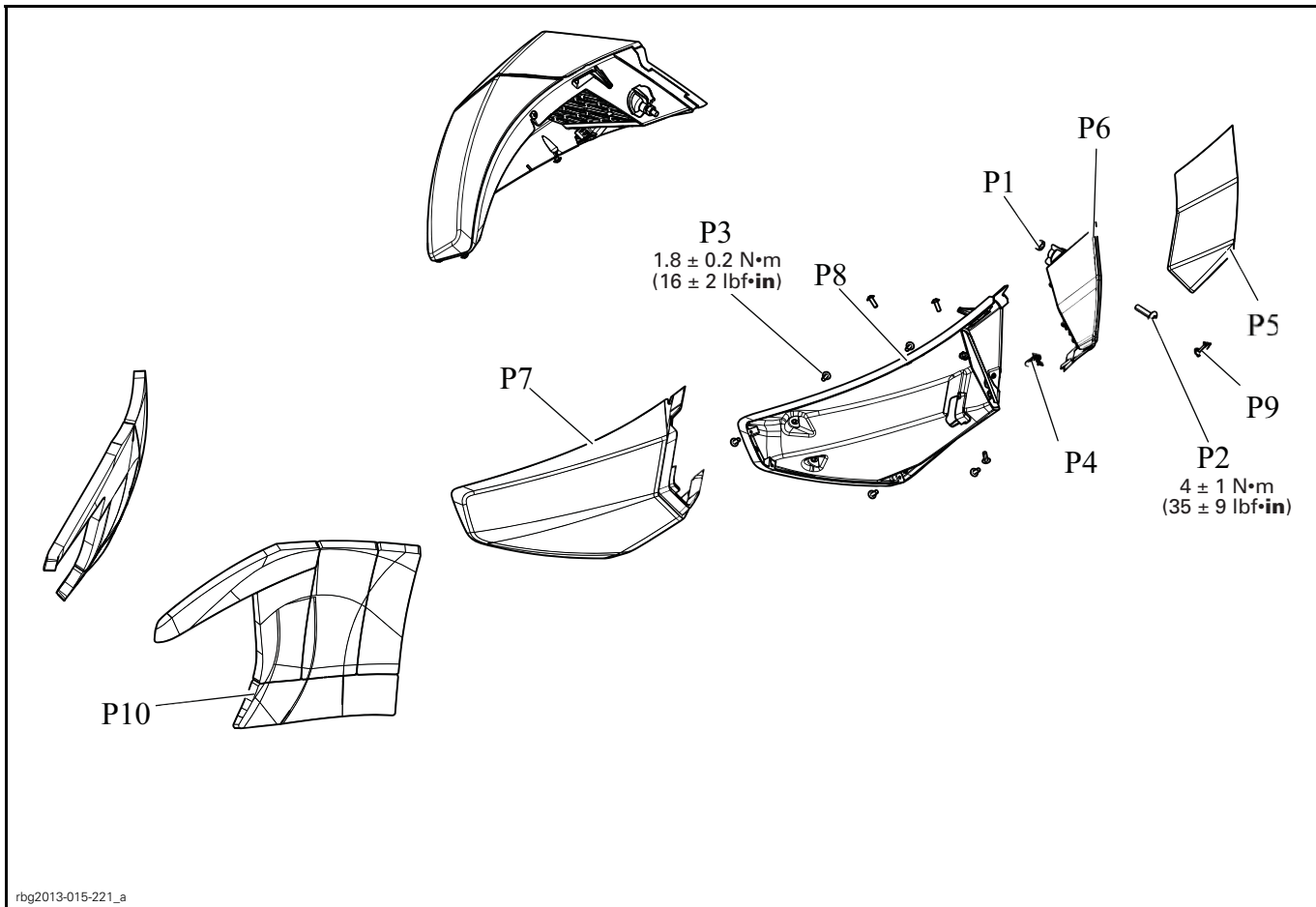

REQUIRED ITEMS

ITEM	DESCRIPTION	QUANTITY
P1	M6 nut	2
P2	M6 X 25 screw	2
P3	K40 X 10 screw	18
P4	Panel clip	2
P5	Front trim (LH & RH)	2
P6	Grill (LH & RH)	2
P7	Rear trim (LH & RH)	2
P8	Air scoop (LH & RH)	2
P9	Screw cap (LH & RH)	2
P10	Acoustic foam (LH & RH)	2

NOTE: Ensure not to scratch the panels.

1. Remove the grill from the RH top side panel.

1.1 Discard clips and grill.

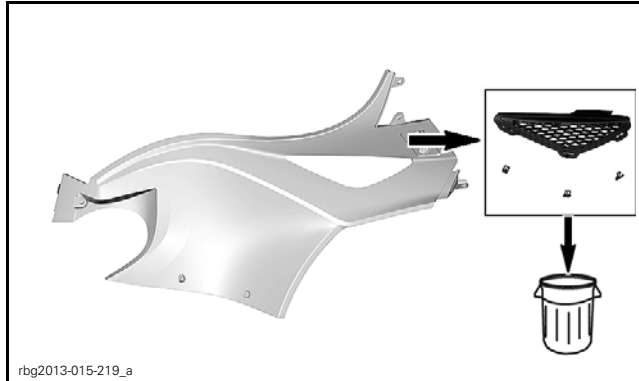

2. Position the RH cutting jig on the RH top side panel.

3. Trace the cutting jig outline onto the top side panel.

NOTE: Push the cutting jig as indicated while tracing.

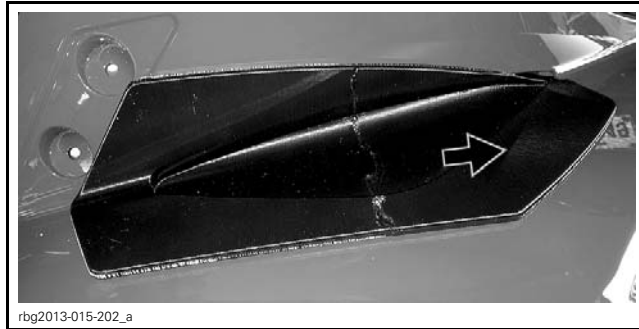

NOTE: Don't cut the holes (X).

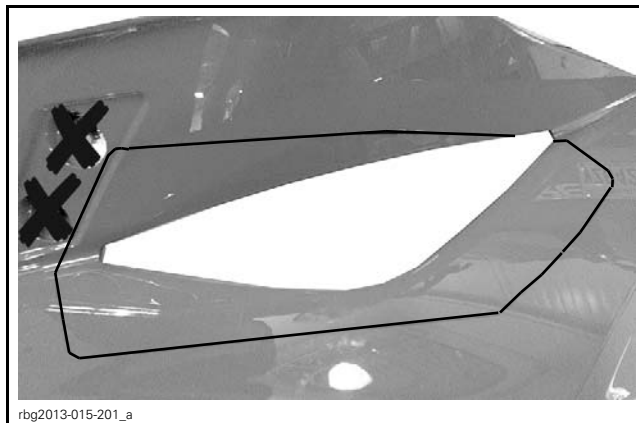

4. Use tape to protect painted panels.

5. Cut along the line following the indicated direction.

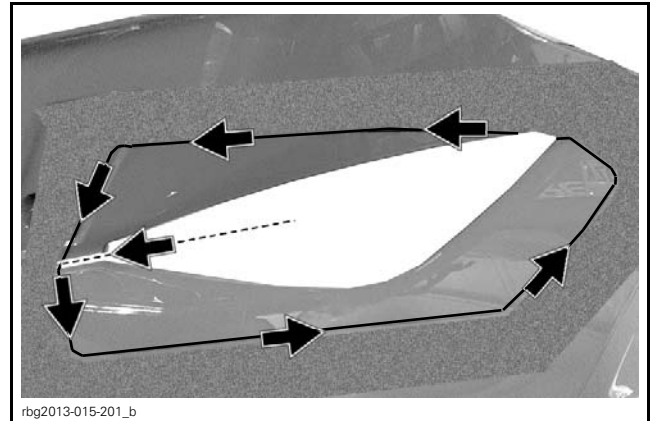

NOTE: A pneumatic reciprocating saw with a narrow metal blade works well.

6. Break off and discard the pieces from the panel.



7. Install panel clip [P4] on grill [P6].

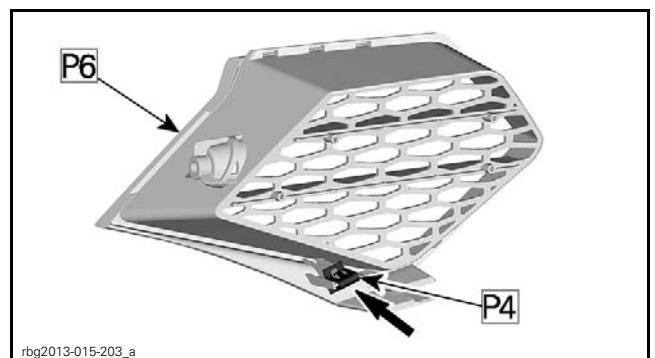

8. Install grill [P6] on air scoop [P8].

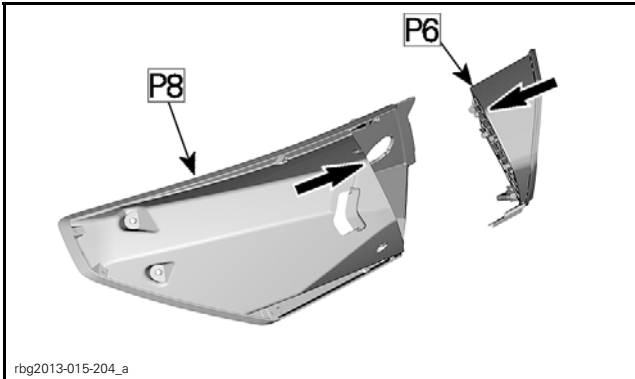

NOTE: Check fit.

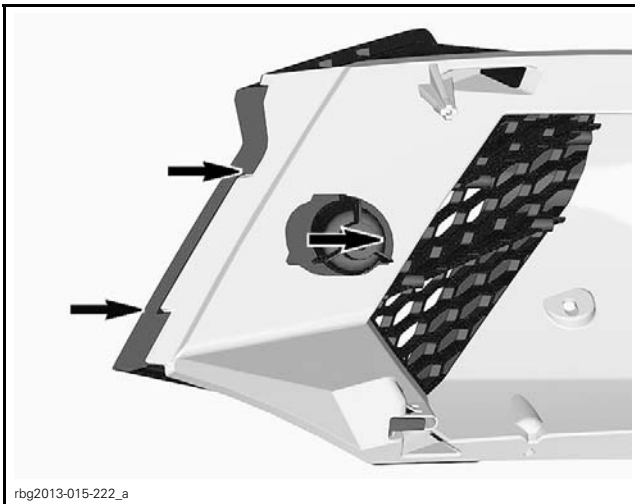

9. Use nut [P1] and screw [P2] to temporarily install air scoop on top side panel.

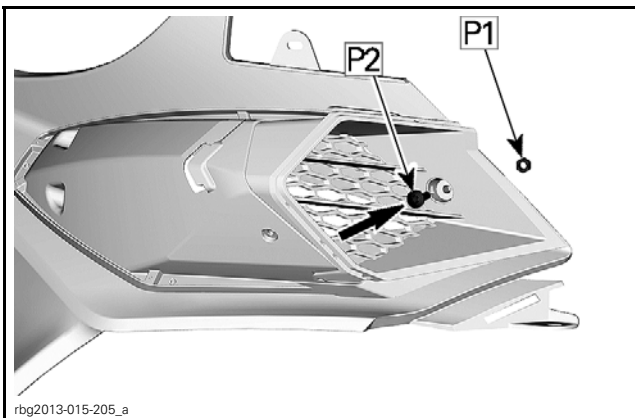

10. Use a spray can straw dipped in paint to mark the 5 holes.



NOTE: Hold air scoop to obtain the best fit on the top side panel.



1. Minimize gap

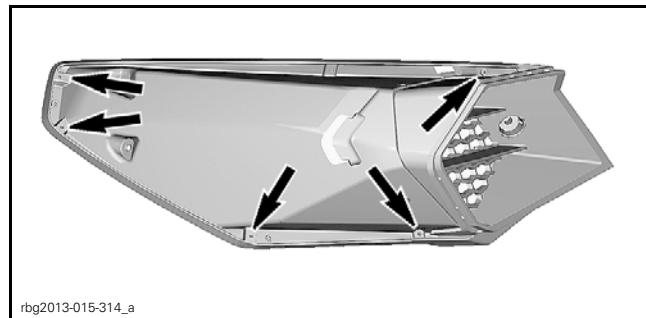

11. Remove air scoop from top side panel.

12. Drill through marks with a **5 mm (13/64 in)** bit.

13. Install air scoop and secure with nut [P1] and screw [P2].

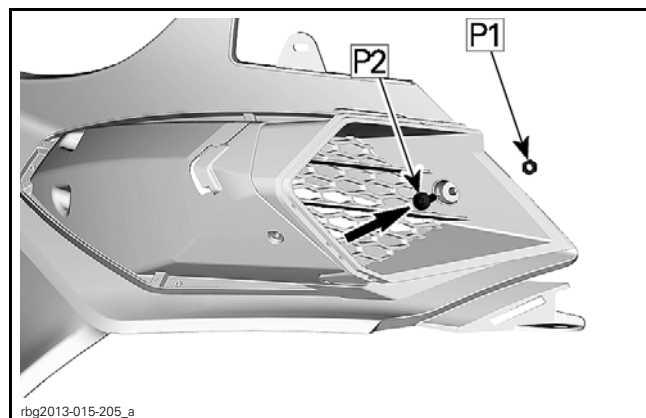

14. On other side of top side panel, secure with screws [P3]. Hold in place for best fit.

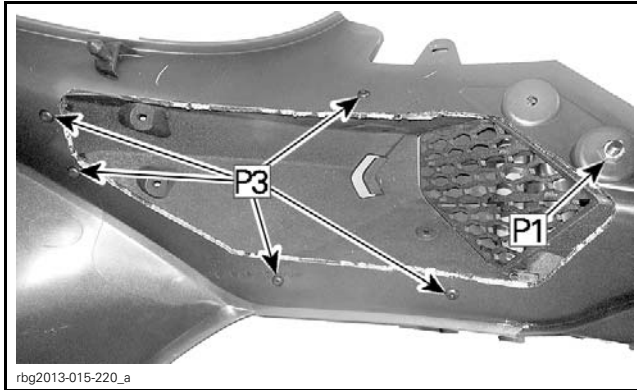

15. Trim top side panel so that it is flush with the inside of air scoop.

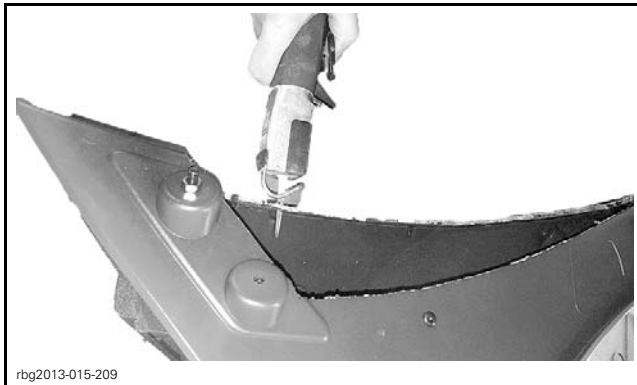

16. Remove nut [P1] and screw [P2], discard nut.
17. Install rear trim [P7] and secure with screws [P3].

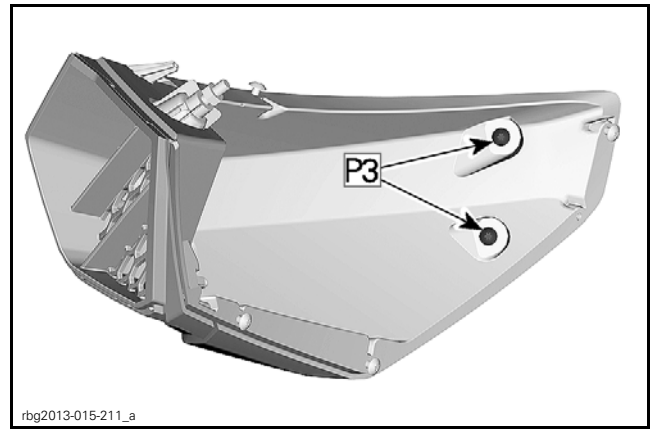
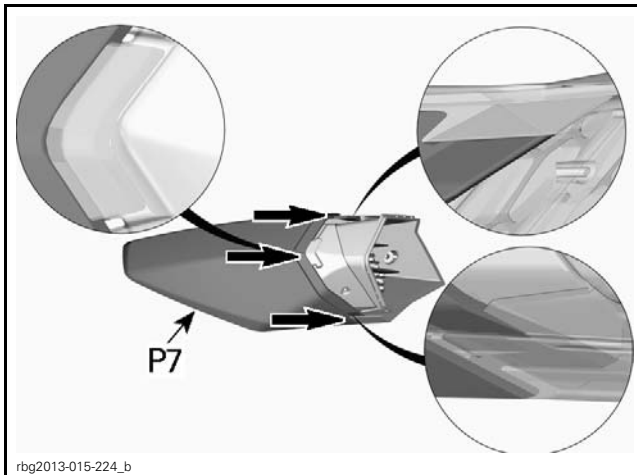

18. Install front trim [P5].

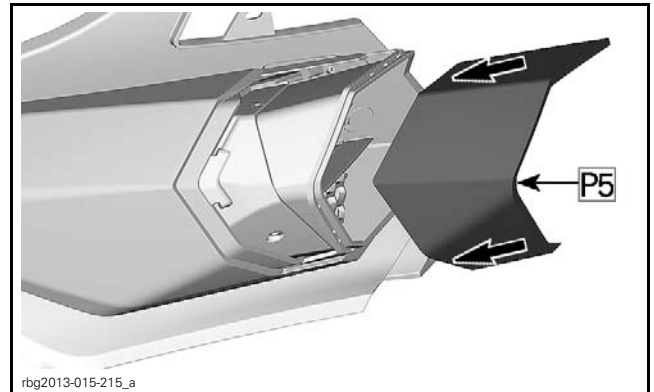

19. Ensure proper alignment.

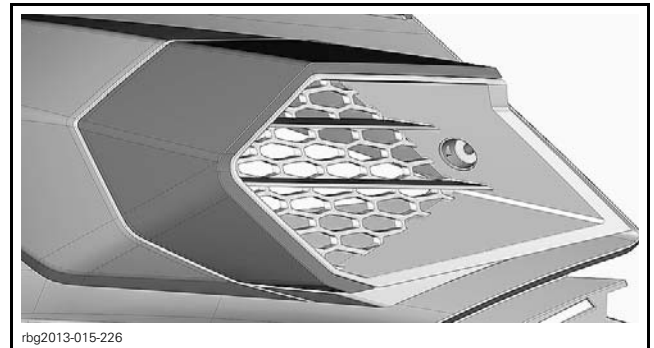

20. Secure with screws [P3] from inside.

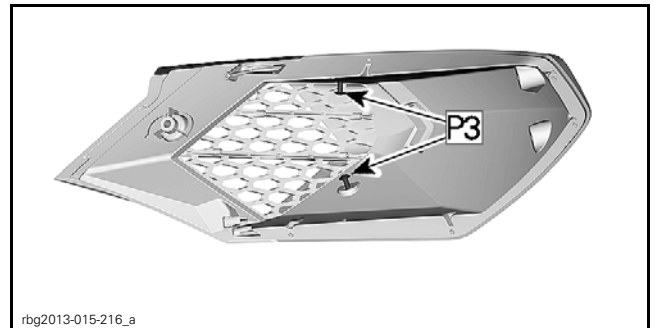

21. Clean the inside of the top side panel with isopropyl alcohol.
22. Position and stick acoustic panel [P10] on the inside of the top side panel.

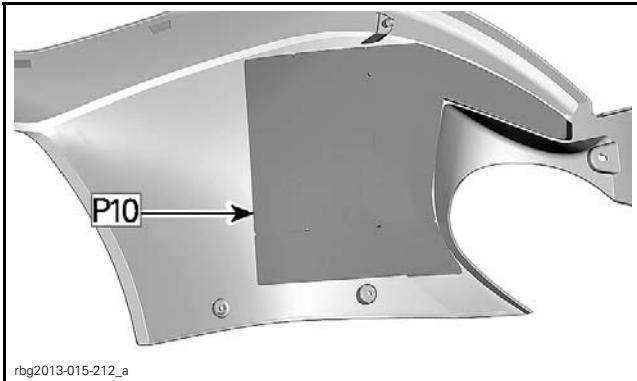

23. Install top side panel.
24. Cover screw with cap [P9].

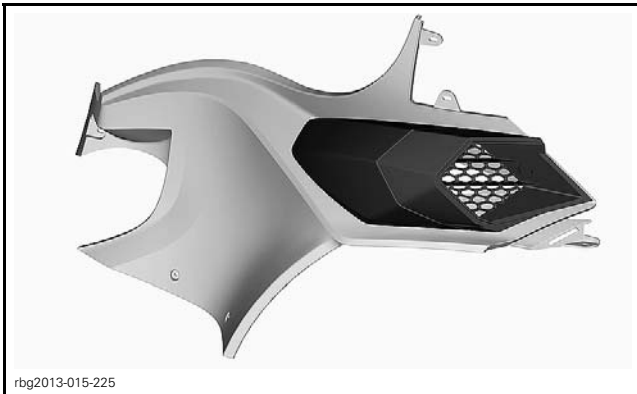
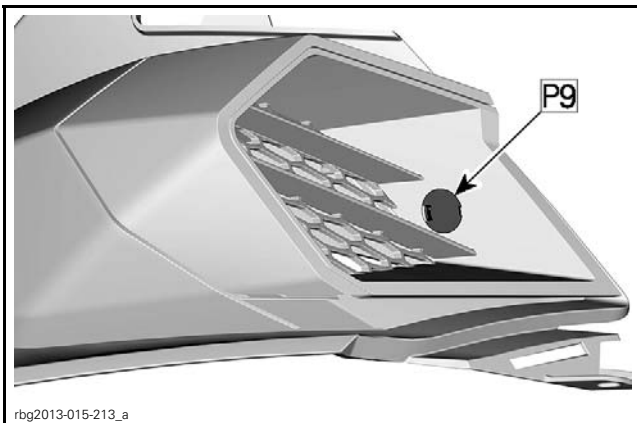

25. Repeat procedure on other side.
- Reinstall all components.

Updating the ECM

REQUIRED ITEMS		
ITEM	DESCRIPTION	QUANTITY
P1	EPA compliance label	1
B.U.D.S.	Version R3.6.1 (or newer) for Roadster	N/A

NOTICE The BUDS update and the fuel system kit are designed to work together. To avoid severe engine damage, only run engine when all updates are completed.

REPAIR TIP
While ECM is updating, clean the frame with isopropyl alcohol and stick new EPA Compliance Label [P1] on the frame under the seat so that it overlaps the old vacuum hose routing, as shown.

NOTE: This label has a security feature that allows it to be installed only once, trying to remove it will void its use.



Computer and Vehicle Preparation

NOTICE

Continuous power to the computer and to the vehicle is mandatory during this operation or damage to a module could occur.

Be sure to disable the computer screen saver.

If using a portable computer, be sure to provide a continuous supply of electrical power by connecting it to a wall outlet.

To ensure there is enough power to the vehicle electronic modules to complete the software updates, use a portable power pack.

NEVER use a battery charger instead of portable power pack. The battery charger may cause electrical noise causing problems during the update.

These software updates of the vehicle modules will take some time to complete and MUST NOT be interrupted.

Although computer screen may blank or may seem to freeze for a while, do NOT interrupt B.U.D.S. to allow updates to be completed. Do not touch the PC.

Although the cluster will blank, do NOT interrupt B.U.D.S. to allow updates to be completed. Do not touch the vehicle.

1. Ensure the vehicle battery is fully charged.
2. Connect a portable power pack (fully charged) to the vehicle battery.

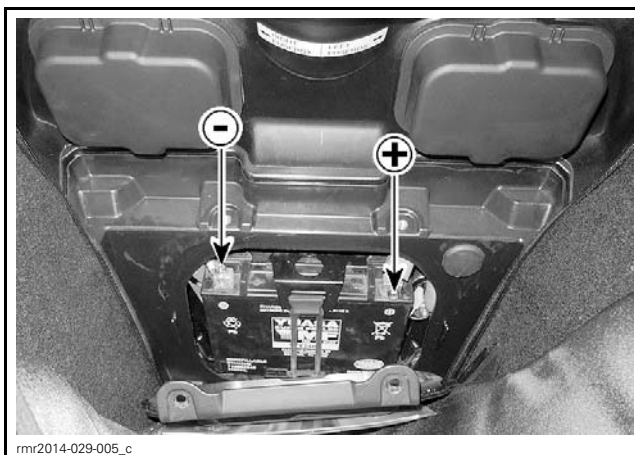

CONNECTION AT BATTERY POSTS, BEHIND BATTERY ACCESS PANEL IN FRONT STORAGE COMPARTMENT

ECM Software Update

1. Connect B.U.D.S..
2. Click on Read Data.

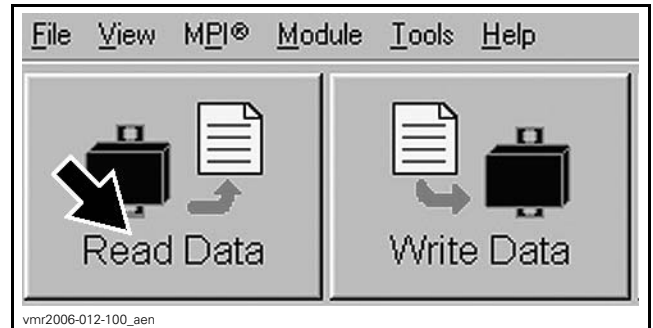

3. Before proceeding with the update, fault codes relating to a current customer complaint should be repaired; all other fault codes should be cleared.
4. Follow instructions on screen.

NOTICE While the ECM is being updated, an hour glass will appear on the computer. The computer screen and cluster might also go blank. DO NOT TOUCH ANYTHING (PC and vehicle).

5. When the following message appears, turn ignition key to ON then click the "OK" button.



6. The ECM software update is completed.

Update Validation

1. Click on Read Data button.

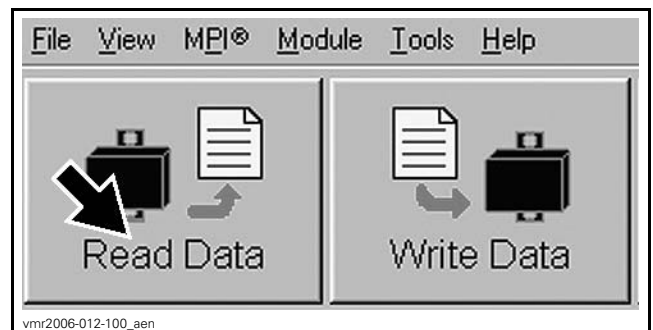

READ DATA BUTTON

2. Check if the update has been successful.

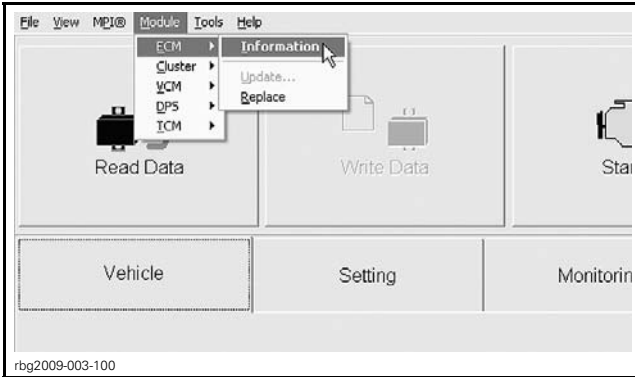

MODULE, ECM, INFORMATION

3. Look at the "BRP Assembly Number", compare with list in table.

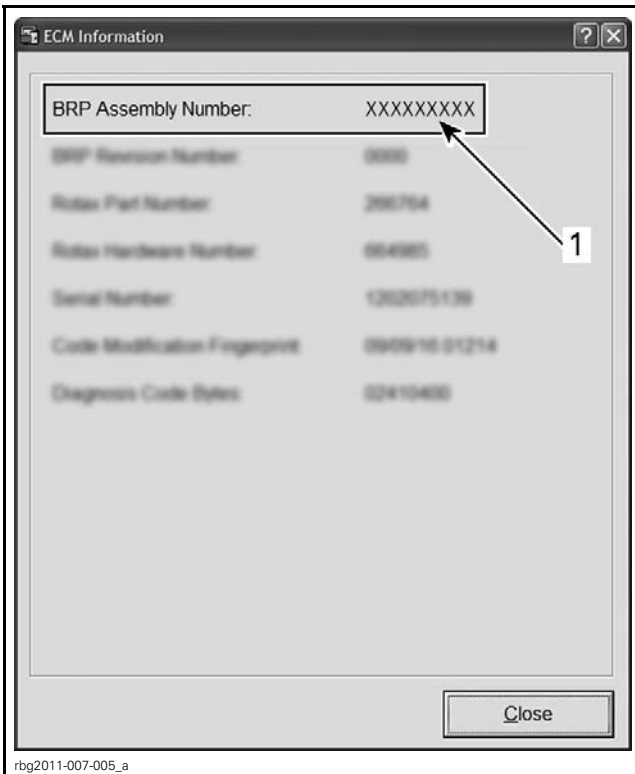

TYPICAL

1. BRP Assembly number

ECM INFORMATION	
BRP assembly number	420 666 632 420 666 637

4. If one of the numbers in the table is found in B.U.D.S., then the update was successful.

4.1 If any other number is found, repeat the update procedure.

TPS Reset

1. In B.U.D.S., click the items in the illustrated order.

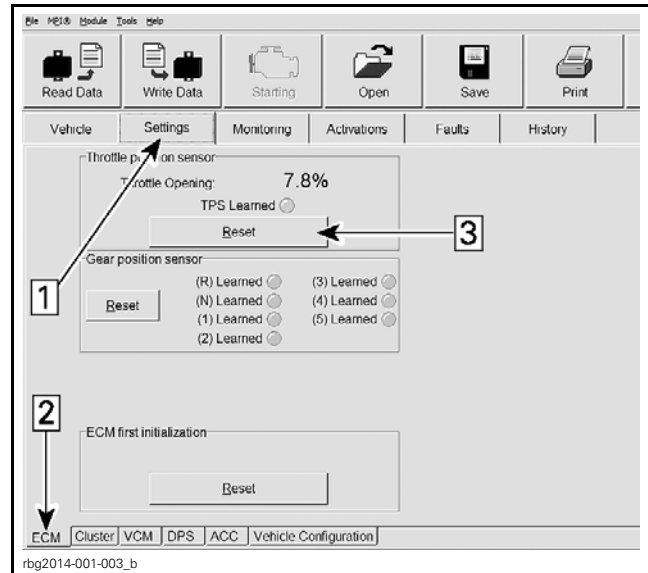

Step 1: Setting tab

Step 2: ECM tab

Step 3: Reset (TPS)

2. When the following message appears, click "OK".

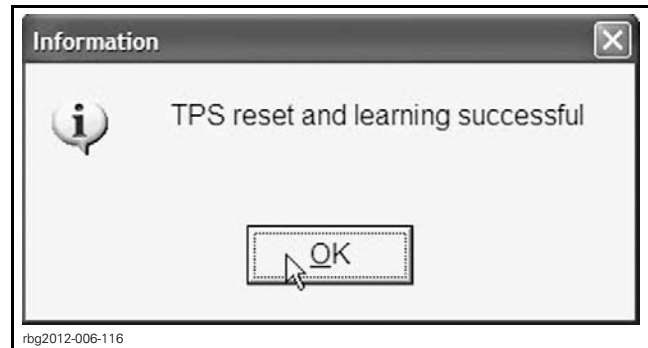

CLICK "OK"

Clearing Faults

1. In B.U.D.S., click on Read Data.

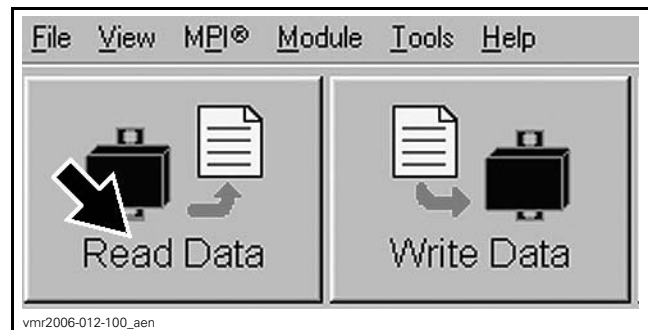

READ DATA BUTTON

2. Click the items in the illustrated order.

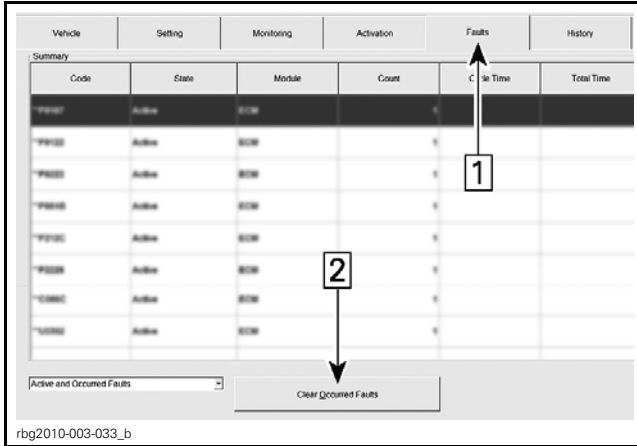

CLEARING FAULTS

Step 1: Faults

Step 2: Click "Clear Occurred Faults" button

3. When the following message appears, click "Yes".

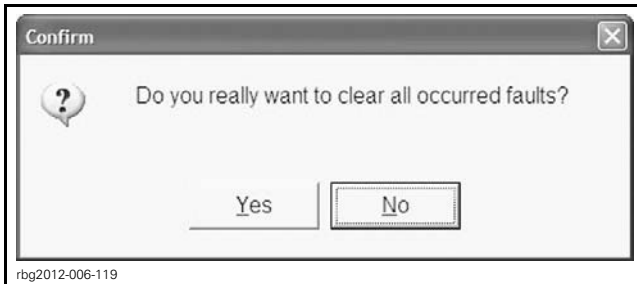

CONFIRM CLEAR FAULTS REQUEST - "YES"

NOTE: To clear all faults, it may be necessary turn the ignition key OFF, wait a few seconds, turn the ignition key back ON and activate the **Clear Occurred Faults** button once more.

- 4. Turn ignition key OFF.
- 5. When the following message appears, turn ignition key to ON and wait until the message vanishes.



- 6. Click on the **Clear Occurred Faults** button again and ensure all faults are cleared.
- 7. Turn ignition key OFF.

NOTICE To avoid potential vehicle damage, it is very important to turn ignition key off **BEFORE** exiting B.U.D.S. or unplugging the MPI diagnostic cable from the vehicle.

8. Unplug MPI diagnostic cable from vehicle.

WARRANTY

Submit a warranty claim using the following information.

For claiming procedure, refer to the *DEALER/DISTRIBUTOR WARRANTY GUIDE*.

CAMPAIGN NUMBER	2013-0017
Claim Type	Campaign Claim
Flat Rate Time	3.6h
Action	Repair

Click in the *REPAIR* check box while completing your claim on BOSSWeb.



You have questions?

Always refer to BRP's BOSSWeb communication channels for the latest answers to questions that may be raised.

***This page is
intentionally blank***

DRILLING TEMPLATE

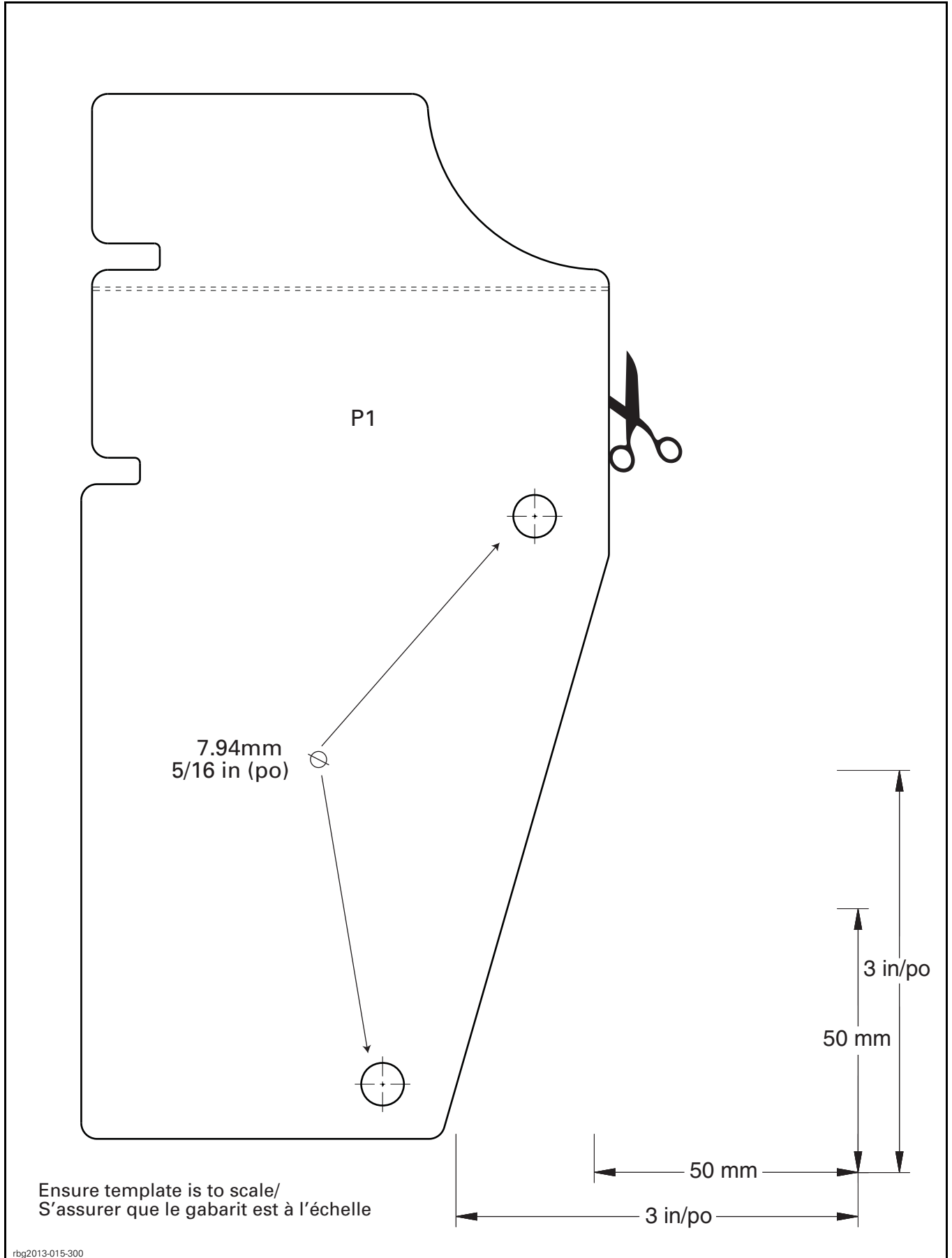

rbg2013-015-300

IMPORTANT SAFETY RECALL NOTICE

This notice applies to your vehicle



565 de la Montagne Street
Valcourt, Québec, Canada J0E 2L0
T 450.532.2211 F 450.532.5133

www.brp.com

May 26, 2015

Re: Can-Am® Spyder® Roadster RT™ 2013 – Elevated Temperature in Engine Compartment

Dear Can-Am Spyder RT 2013 Owner,

This notice is being sent to you following the interim notice sent in February 2015, in accordance with the requirements of the National Traffic Motor Vehicle and Canada Motor Vehicle Safety Acts. BRP has decided that a defect which relates to motor vehicle safety exists on certain Can-Am roadster models and is conducting a safety recall. The remedy is now available.

Our records show that you own a potentially affected vehicle.

What is the potential problem?

Under very hot ambient conditions and low speed riding, the temperature in the engine compartment may rise and thereby increase the risk of a skin burn or a vehicle fire.

Which models are involved?

Can-Am Spyder RT roadster, model year 2013.

What should you do?

Call an authorized BRP Can-Am Roadster dealer and make an appointment to have your vehicle repaired. The solution is the installation of improved body panels and an upgraded fuel system kit. This repair should take approximately 4 hours to complete. The dealer will perform this work at no charge to you.

What should you do until your vehicle is repaired?

Although BRP insist to get all involved vehicles repaired rapidly, you can keep using your vehicle while taking the following precautions in hot riding conditions (ambient temperature of approximately 30 C/85 F and more):

- Avoid idling or slow traffic riding for a long period of time.
- Avoid parking in an enclosed area immediately after your ride, let your vehicle cool down first
- Avoid prolonged direct contact with body panels; wear appropriate riding gear as stated in the Operator's Guide.

What to do if you feel this notice is an error?

This notice was mailed to you according to the most current information we have available. If you no longer own this vehicle or some information in this notice is incorrect, please contact BRP at your earliest convenience.

Ski-Doo
Lynx
Sea-Doo
Evinrude
Rotax
Can-Am

For US residents only

If you believe that BRP has failed or is unable to remedy the defect within a reasonable time, you may submit a complaint to the Administrator, National Highway Traffic Safety Administration, 1200 New Jersey Avenue S.E. Washington, D.C. 20590, or call the toll free Auto Safety Hot Line at 1- 888-327-4236 (TTY: 1-800-424-9153), or go to www.safercar.gov. If you are a vehicle lessor, federal law requires that any vehicle lessor receiving this recall notice must forward a copy of this notice to the lessee within ten days.

Your continued satisfaction with your roadster is important to us. We have taken this action in the interest of your safety and your vehicle's proper operation. We apologize for any inconvenience this may cause you and appreciate your patience while we prepare the remedy for this condition. If you have questions or need assistance:

- Visit www.can-am.brp.com
- Or call: 1-888-272-9222
9:00 AM to 9:00 PM Eastern time Monday to Friday

Sincerely,
After-Sales Service Department



565 de la Montagne Street
Valcourt, Québec, Canada J0E 2L0
T 450.532.2211 F 450.532.5133

www.brp.com

May 26, 2015

Can-Am® Spyder® RT™ 2013 - Updated Maintenance Schedule - Operator's Guide Label

Dear Can-Am Spyder owner,

You are receiving this decal along with the Safety Recall Notice letter - Can-Am Spyder Roadster RT 2013 – Elevated Temperature in Engine Compartment.

This updated maintenance schedule will take effect when your vehicle has been repaired as per the above described safety recall notice.

EVERY 46 000 KM (28,500 MI)
Replace the rear sprocket bearing.
Replace the canister pre-filter (if so equipped).

In the Operator's guide **Maintenance Schedule**, affix the provided label over the existing 46 000 KM (28,500 MI) maintenance specification.

We apologize for any inconvenience this situation may have caused.

Sincerely,
After-Sales Service Department

Ski-Doo
Lynx
Sea-Doo
Evinrude
Rotax
Can-Am