



TECHNICAL SERVICE BULLETIN

Date: July 1, 2015
Expires:

Victory Motorcycle

Bulletin Number: V-15-03
Model Years: 2015

Safety Bulletin Service Bulletin Service Alert Fax Production Update Kit

Distribution: Owner / Principal Service Manager Sales Manager Parts Manager Technicians

This Service Bulletin is located at www.polarisdealers.com

-Confidential and Proprietary-

IMPORTANT! Vehicle registration and registration renewal may be blocked by the California DMV based on the completion status of this Service Bulletin.

SUBJECT: 2015 Victory Motorcycles – Idle Air Control Replacement / ECM Reflash

NOTE: Service Bulletin V-15-03 only applies to California Air Resource Board (CARB) certified motorcycles.

PURPOSE:

Victory has determined that some 2015 Victory motorcycle models, designated for sale in the State of California, may not meet emission control standards set forth by the California Air Resource Board (CARB). Some 2015 Victory motorcycles, equipped with California emission control components, may not effectively utilize stored fuel vapor from the charcoal canister. Victory has developed an updated Idle Air Control distribution hose which enables the engine to draw fuel vapor from the charcoal canister into both front and rear cylinders resulting in more complete utilization of stored fuel vapor. The ECM software must also be updated.

Victory has issued this Service Bulletin in an effort to preemptively complete the repairs necessary to bring affected motorcycles into CARB compliance. Failure to complete the repairs outlined in this communication before October 30, 2015 may result in a hold being placed on vehicle registration.

NOTE: This Service Bulletin must be performed on all affected motorcycles residing in or out of the State of California.

WHAT YOUR DEALERSHIP SHOULD DO:

1. Review your dealership's inventory to locate potentially affected models.
 - a. Use 'Unit Inquiry'.
 - OR**
 - b. Locate the 'Service and Warranty' dropdown, click on STOP Site.
 - c. On the left hand side of the page, under 'STOP Site Links' click on 'Service Bulletins'.
 - d. Locate the service bulletin number V-15-03 click on the 'All VINs' link located on the right.
 - e. The 'All VINs' page will display all affected VINs within your dealership's inventory.
2. Follow the instructions outlined in this Service Bulletin to update the IAC hose bundle and ECM software as outlined on page 3 of this bulletin.
3. File a warranty claim using the bulletin number immediately after completion of this bulletin.

CUSTOMER NOTIFICATION:

A customer notification letter will be sent to all registered owners of affected machines. In addition to the notification letter sent by Victory Motorcycles, dealers are required to review sales records and contact consumers who have purchased an affected vehicle. Make arrangements to perform the steps outlined in this Service Bulletin immediately.

PARTS INFORMATION:

PART NUMBER / DESCRIPTION	7170107 (QTY.1) – Service Bulletin Completion Decal 1205217 (QTY. 1) IAC Hose Assembly
PARTS AVAILABILITY	Available to order
DIRECT-SHIP FROM POLARIS?	NO
TO BE ORDERED BY DEALER?	YES

Parts Return or Disposal Information:

Dealers & Distributors: Under no circumstances shall the part removed in this repair be re-used, sold, or re-purposed for another application. It is your dealership / distributorship's responsibility to make sure every part replaced is taken out of circulation and disposed of properly.

For North American Dealers: Once the warranty claim for each unit has processed, please review the "Check Returned Parts List" on your dealer website to determine whether or not Polaris has asked for the part(s) to be returned. If the part(s) were not identified as needing to be returned to Polaris, please dispose of the part(s) properly.

WARRANTY CLAIM INFORMATION:

A single group claim may be submitted listing the complete (17 digit) Vehicle Identification Number for machines with the same model number. File claim type **SB (Service Bulletin)**. DO NOT PUT MORE THAN ONE MODEL NUMBER ON A CLAIM.

SERVICE BULLETIN #	V-15-03
CLAIM TYPE	SB (Service Bulletin)
LABOR ALLOWANCE	0.9 Hrs (54 minutes)
CLAIM PART NUMBERS	N/A - Auto Process Bulletin

SERVICE BULLETIN COMPLETION DECAL:

A Service Bulletin Completion Decal (PN 7170107) must be completed for this bulletin repair. Place the decal beneath the LH side cover as shown (beneath console cover on Vision). If you require more decals, order them through normal Polaris parts ordering channels.

Sincerely,



Doug Koch
Technical Service and Warranty Manager

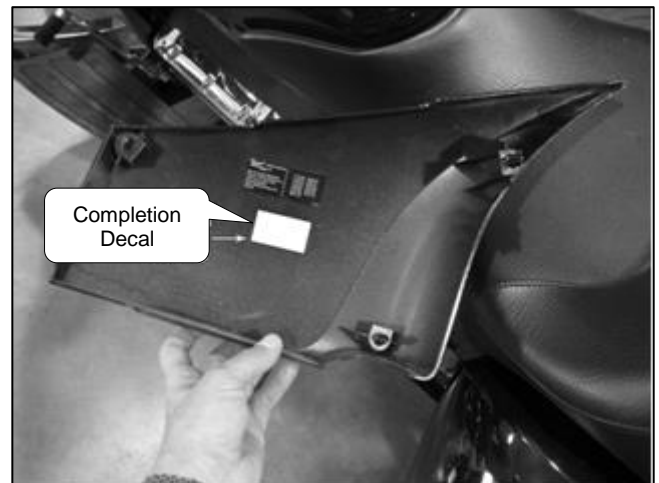

IDLE AIR CONTROL HOSE REPLACEMENT PROCEDURE:

CAUTION:

- Allow engine and exhaust to cool completely before disconnecting fuel line or removing tank.
- Store the fuel tank in a safe place during service to avoid damaging painted surfaces.

IMPORTANT: The following procedure summarizes IAC hose replacement for all Victory Motorcycle models affected by this Service Bulletin. For more detailed information pertaining to Fuel System Service, refer to Chapter 5 in the applicable Victory Motorcycle service manual. If you have any questions that cannot be answered by the service manual, please call Victory Technical Service.

1. Place the motorcycle on a lift table with the front wheel clamped in a wheel vise.
2. Remove the IAC cover (1) and Ignition Switch cover (2).
3. **ALL MODELS EXCEPT VISION:** Remove fuel tank as outlined in service manual.

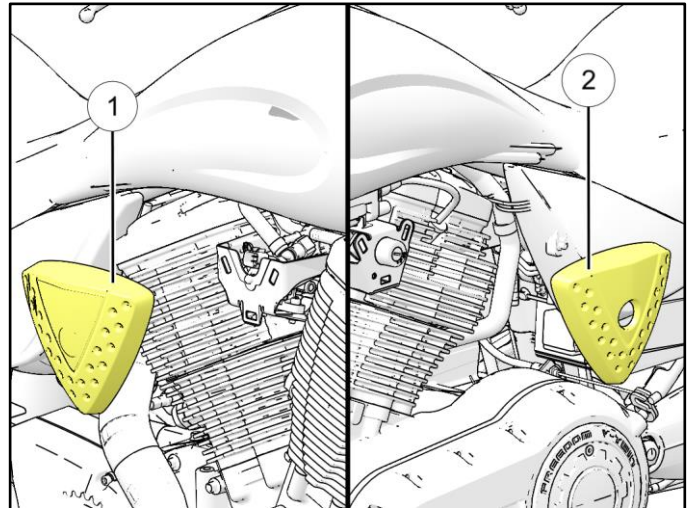

4. Remove the wire dart (3) by squeezing the end of the clip and pushing to the inside of the IAC cover bracket.
5. Disconnect the IAC harness connector from IAC receptacle (4).
6. Remove IAC bracket screws (5) using a 5mm ball-drive hex wrench.
7. Using a flat head screwdriver, press the three rubber hose fittings off of the IAC module and remove the bracket and IAC as an assembly.

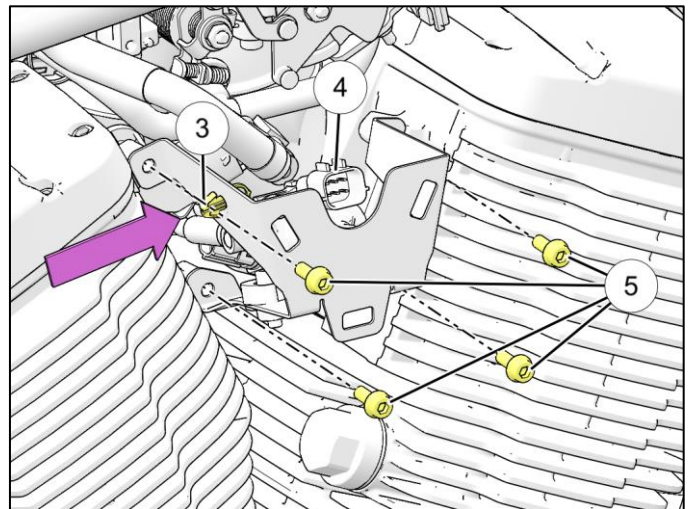

8. Remove high-tension leads (HTL) from coil ⑥.

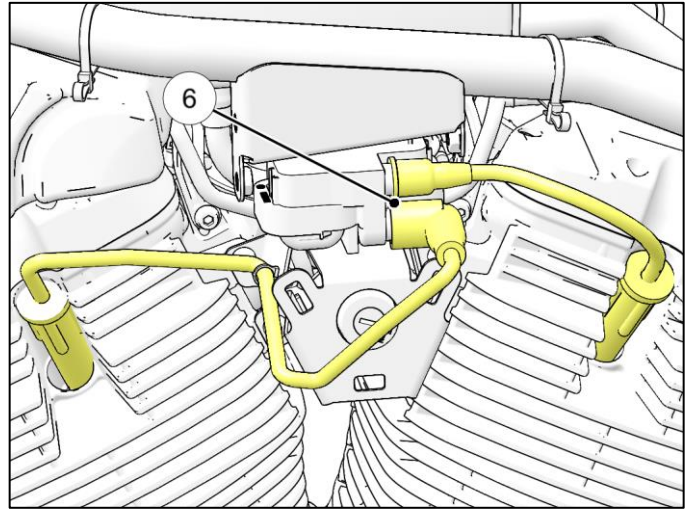

9. Remove Ignition Switch bracket screws ⑦ using a 5mm ball-drive hex wrench.

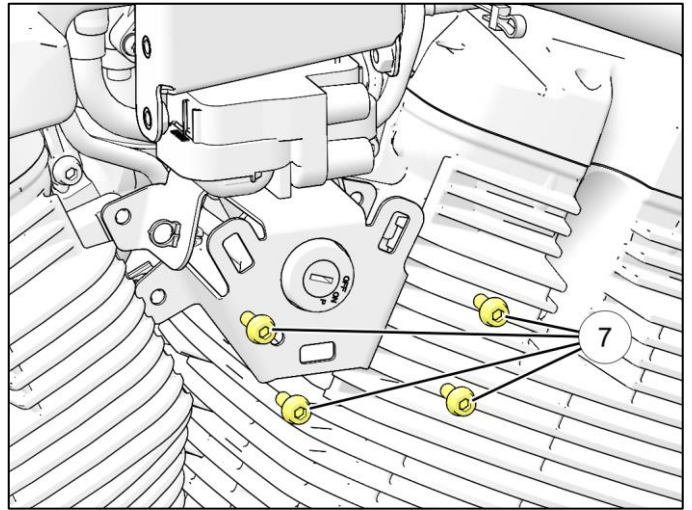

10. Disconnect the primary wire harness from coil ⑧ and ignition switch connector ⑨.

11. Remove the coil, switch and bracket as an assembly.

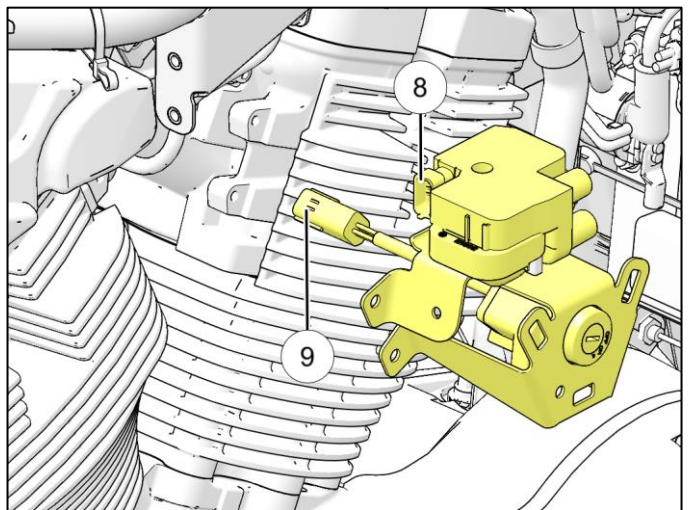

12. Disconnect the Charcoal Canister purge line ⑩ from the Idle Air Control T-Fitting.
13. Disconnect the supply fitting ⑪ from the air box, the forward IAC fitting ⑫ and the rear IAC fitting ⑬ from the throttle body.
14. Unplug the Cylinder Head Temperature sensor (CHT) connector to provide additional clearance when fitting the new IAC hose assembly.

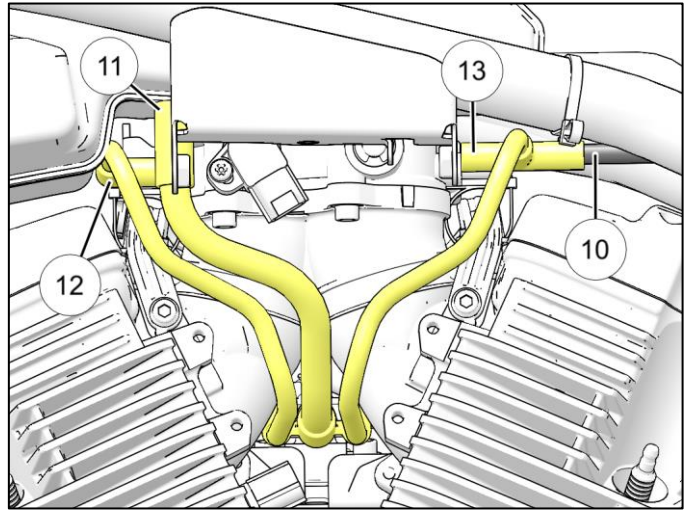

15. Apply P80 (or similar) lubricant to hose connections on the new IAC hose bundle.

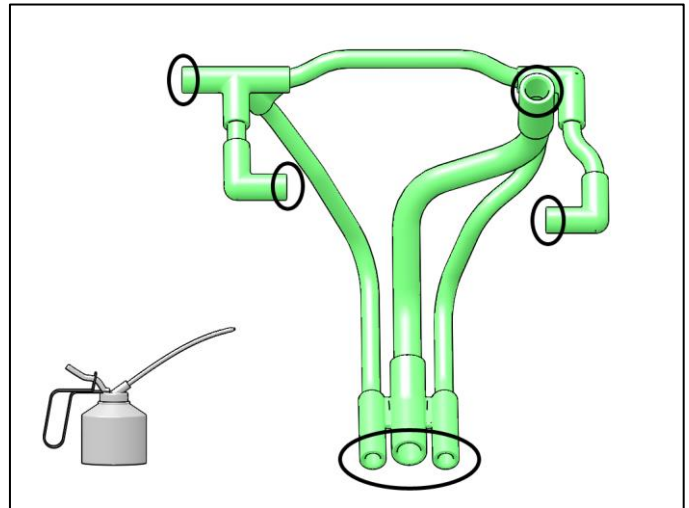

16. Feed the IAC hose assembly through the engine from the primary cover side and connect the front and rear throttle body fittings ⑭, the air box fitting ⑮ and the charcoal canister fitting ⑯.
17. Reconnect the CHT sensor and verify that the wire harness is not pressing on the IAC hose assembly causing it to flex.

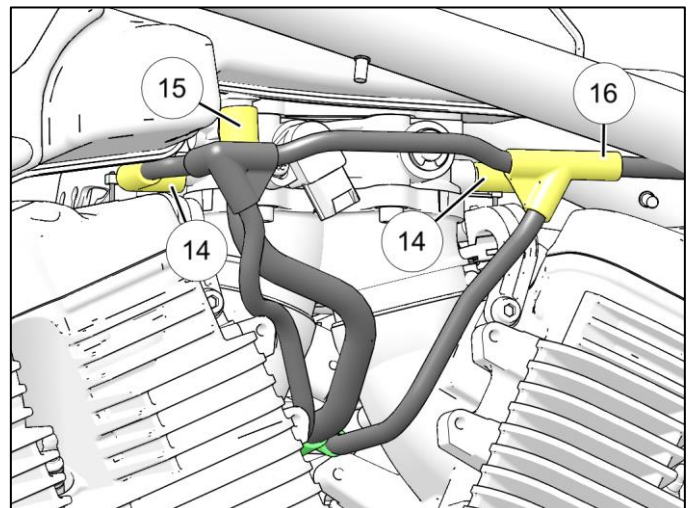

18. With the help of an assistant, hold the IAC hose assembly in position and press the IAC module (17) into the three rubber hose fittings (18) until fully seated.
19. Hand-tighten the IAC / bracket assembly screws and torque to specification in an "X" pattern.

TORQUE:

IAC Bracket Screws: **88.5 in-lbs (10.0 Nm)**

20. Install the wire dart into the IAC bracket making sure the wire is on the inside of the bracket.
21. Reconnect the IAC module electrical connector.
22. Reconnect the TPS sensor electrical connector.
23. Reconnect the ignition switch electrical connector.
24. Hand-tighten the coil / bracket assembly screws and torque to specification in an "X" pattern.

TORQUE:

Ignition Coil Bracket Screws: **88.5 in-lbs (10.0 Nm)**

25. Reconnect the spark plug wires to the spark plugs.
26. Install the fuel tank and seat as outlined in the service manual.
27. Prime the fuel system as outlined in the service manual and verify that no leaks are present.

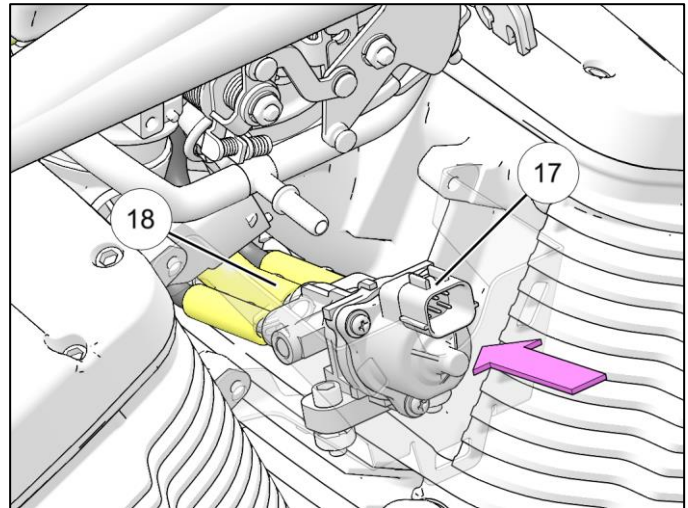

ECM REPROGRAMMING PROCEDURE:

NOTE: Motorcycles equipped with a STAGE exhaust kit should contact Victory Technical Service to obtain a Calibration ID.

1. Verify that Digital Wrench version 3.7 Update 06/29/15 has been installed on your PC or laptop and proceed to STEP 6.

If you do not have Version 3.7 – Update 06/29/15 or higher installed, you must first download it before proceeding with the reflash.

2. Go to your dealer homepage and select the most recent **Digital Wrench Annual Version** from the **Service and Warranty** dropdown menu, download and install.
3. Go to your dealer homepage and select **Digital Wrench Updates** from the **Service and Warranty** dropdown menu.



4. Click on **Digital Wrench Version 3.7 Updates**.
5. Download and install **Digital Wrench Version 3.7 Update 06/29/15 or higher**.
6. Connect SmartLink Module cables to PC and vehicle.
7. Open the Digital Wrench program.
8. Select the model year, product line and vehicle description by selecting the "Change Vehicle Type" icon.
9. Select the **Special Tests** icon.
10. Select **Engine Controller Reprogramming**.
11. Follow the on-screen prompts until the ECM has been updated.
12. At this time you should check / clear any stored fault codes and test ride the motorcycle.

EXAMPLE OF CONSUMER NOTIFICATION



Victory Motorcycle Division
Polaris Industries Inc.
2100 Highway 55
Medina, MN 55340

IMPORTANT EMISSIONS INFORMATION

This notice applies to your vehicle

VIN: INSERT VIN HERE

**Subject: 2015 Victory Motorcycles (CA Models Only)
IAC Replacement / ECM Update
PLEASE READ IMMEDIATELY**

July 1, 2015

Dear Victory Owner:

The Victory Motorcycle Division of Polaris Industries Inc. has determined that some 2015 Victory motorcycle models, designated for sale in the State of California, may not meet emission control standards set forth by the California Air Resource Board (CARB). Our records indicate that you have purchased a potentially affected vehicle.

Victory has issued this notification in an effort to preemptively complete the repairs necessary to bring affected motorcycles into CARB compliance. Repairs must be completed before October 30, 2015 to ensure uninterrupted riding. Affected motorcycles must have the repair work performed before the California Department of Motor Vehicles will renew your registration.

The reason for this update:

Some 2015 Victory motorcycles, equipped with California emission control components, may not effectively utilize stored fuel vapor from the charcoal canister. Victory has developed an updated Idle Air Control distribution hose which enables the engine to draw fuel vapor from the charcoal canister into both front and rear cylinders resulting in more complete utilization of stored fuel vapor. The updated hose assembly, when installed, will not affect performance or reliability of the motorcycle.

What Victory and your dealer will do:

Victory has issued *Service Bulletin V-15-03* to all Victory dealers, with instructions required to replace the Idle Air Control (IAC) distribution hose assembly. At this time, the Engine Control Module (ECM) will receive an updated software calibration to maintain optimum performance. Repairs will be made by an authorized Victory Motorcycle dealer at no cost to you. The actual repair should take under one hour to perform; however, it may take longer due to service scheduling requirements.

What you should do:

Please call your authorized Victory Motorcycle dealer to schedule an appointment to have the bulletin repair performed. Do not attempt repairs yourself. Repairs must be done only by an authorized Victory Motorcycle dealer.

If you have questions or if you need more information:

While your Victory dealer is in the best position to answer your questions, if you have any questions that your dealer cannot address, or if you need assistance finding a Victory dealer, please visit the Victory Motorcycle web site at www.victorymotorcycles.com or contact our Victory Consumer Service Department by calling 1-877-737-7172.

This notice was mailed to you according to our most current registration information. If you no longer own your Victory motorcycle, please contact your local Victory dealer to have the ownership information changed. The Victory Consumer Service Department cannot change ownership information without identification.

Please accept our apologies for any inconvenience this may cause you. Your continued satisfaction with your Victory motorcycle is our top priority. Thank you for your prompt attention to this matter.

Sincerely,

Victory Motorcycles