

D/C Cut Fuse Installation during PDS Installation During PDS

Service Category General

Section Pre-Delivery Service

Market USA

Lexus Supports
ASE Certification 

Applicability

YEAR(S)	MODEL(S)	ADDITIONAL INFORMATION
2016	RC F, RC200T, RC300, RC350	

Introduction

To minimize battery discharge during transportation and storage, the D/C Cut fuse has been removed at the assembly plant and temporarily stored in the blank space of the relay block in the engine compartment.

During Pre-Delivery Service (PDS), reinstall the D/C Cut fuse into its original location.

Warranty Information

OP CODE	DESCRIPTION	TIME	OFF	T1	T2
N/A	Not Applicable to Warranty	—	—	—	—

D/C Cut Fuse Installation during PDS

Installation Procedure

Remove the D/C Cut fuse from the blank space of the relay block in the engine compartment and install it in the location shown in Figure 1 during Pre-Delivery Service (PDS).

Figure 1

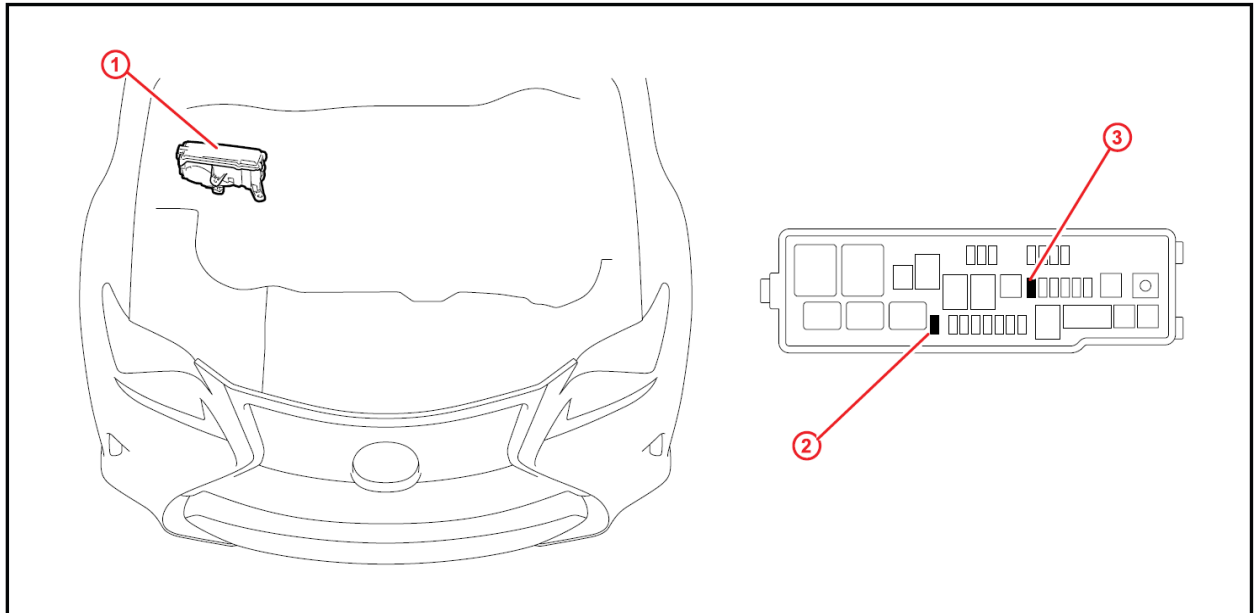

1	Relay Block
2	Remove This D/C Cut Fuse

3	Install D/C Cut Fuse Here (Original Location)
----------	---

NOTE

- Removing the D/C Cut fuse cuts OFF power sources relating to the DOME and MPX-B.
- While the vehicle is stored at the dealership, disconnect the negative (-) battery terminal to prevent battery discharge. Refer to Service Bulletin No. [PG001-06](#), "Battery Maintenance for In-Stock Vehicles & Pre-Delivery," for battery maintenance information.