



SI B01 12 15
Warranties

December 2015
Warranties

SUBJECT

N63 Engine Crankcase Ventilation “Connecting Line” Hoses: Limited Warranty Extension to 10 Years/120,000 Miles

MODEL

E70 (X5 xDrive50i)

Model Year 2011 produced from 8/6/2009 to 3/28/2011

E71(X6 xDrive50i)

Model Years 2009, 2010 and 2011 produced from 9/22/2009 to 3/26/2011

F01 (750i Sedan)

Model Years 2009, 2010 and 2011 produced from 5/15/2008 to 2/28/2011

F01 (750i xDrive Sedan)

Model Years 2010 and 2011 produced from 5/26/2009 to 02/28/2011

F01 (BMW ALPINA B7 and BMW ALPINA B7 xDrive)

Model Year 2011 produced from 3/4/2010 to 02/15/2011

F02 (750Li Sedan LWB)

Model Years 2009, 2010 and 2011 produced from 3/12/2008 to 2/25/2011

F02 (750Li xDrive Sedan LWB)

Model Years 2010 and 2011 produced from 10/15/2008 to 2/28/2011

F02 (BMW ALPINA B7 and BMW ALPINA B7 xDrive LWB)

Model Year 2011 produced from 3/17/2010 to 2/16/2011

F07 (550i Gran Turismo and 550i xDrive Gran Turismo)

Model Years 2010 and 2011 produced from 3/25/2009 to 8/10/2011

F10 (5 Series Sedan and 5 Series xDrive Sedan)

Model Year 2011 produced from 7/7/2009 to 8/30/2011

With the N63 engine

INFORMATION

For the above-referenced vehicles, BMW of North America, LLC (“BMW NA”) is extending the limited warranty for the **Crankcase ventilation “connecting line” hoses** to:

- **10 years/120,000 miles as determined by the vehicle’s original in-service date**

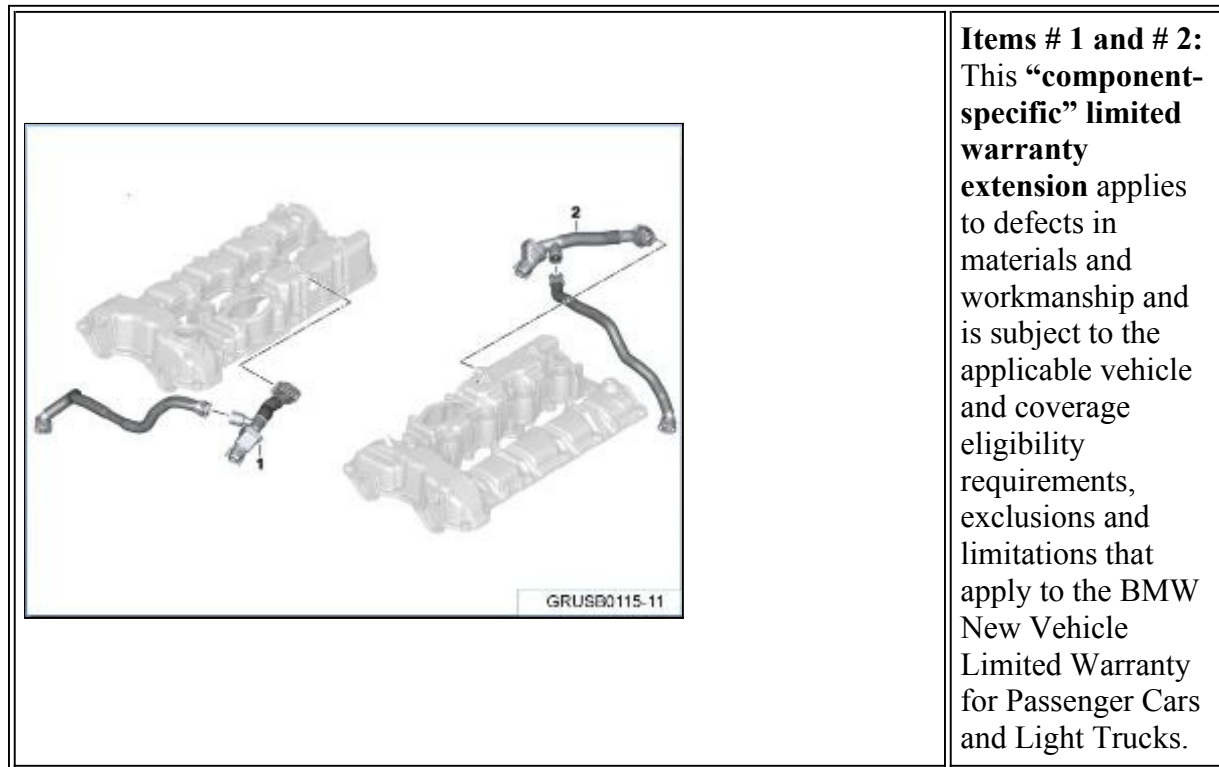

This bulletin is notice of a “limited warranty extension.” This is NOT a notice of a Recall or Service Action.

There is no immediate repair required unless the BMW vehicle is currently experiencing this problem.

Customer Notification Letter – VIN and Component-specific Warranty Extension

Even though this is **NOT** a Recall, BMW NA will be sending VIN-specific customer notification letters in a phased release during the **first quarter of 2016**.

ELIGIBLE BMW VEHICLES

To assist you in identifying the eligible vehicles, the DCSnet Warranty Vehicle Inquiry **will be updated shortly** with the “Vehicle Comment” shown below:

BMW NA has extended the limited warranty for the cylinder head covers crankcase ventilation connecting line hoses on this vehicle to 10 years/120,000 miles as determined from the original in-service date. This component-specific limited

warranty extension is subject to all the applicable vehicle and coverage eligibility requirements, exclusions and limitations that apply to the BMW New Vehicle Limited Warranty for Passenger Cars and Light Trucks. Please see SI B01 12 15.

Note: Always check the DCSnet Warranty Vehicle Inquiry “Vehicle Comments” and the “Repair History (Claims)” sections first, before performing any repairs.

PARTS INFORMATION

Please refer to the Electronic Parts Catalog (ETK/EPC), using the customer’s VIN to locate the applicable replacement part numbers.

Important Notes:

- **Only order these parts in the quantities needed to address customers’ vehicles that have confirmed failures.**
- **“Only in conjunction with” parts:** When applicable, this ETK/EPC item identifies additional part(s) that must also be replaced/installed together with the replacement of the crankcase vent hoses. These “required” additional items are also covered “in-conjunction” and under the terms of this extended limited warranty.
- Also refer to ETK/EPC and the repair instructions for onetime-use fasteners/screws and other information regarding repair-related gaskets, seals, fluid and/or lubricants that also need to be replaced/used and claimed.

WARRANTY INFORMATION

The engine cylinder head cover crankcase ventilation “connecting line” hoses limited warranty extension to 10 years/120,000 miles applies to “eligible US-specification BMW vehicles” that are registered, operated and have their covered repair performed by an authorized BMW center in the United States (including Puerto Rico).

This coverage supersedes the coverage that is provided under the BMW Certified Pre-Owned Program or any BMW Group Vehicle Service Contract that applies to the vehicle.

Should the engine’s crankcase ventilation “connecting line” hoses fail again, these components are covered by the remaining portion of the extended limited warranty coverage period.

The existing limited warranty coverage for all other parts **has not** changed.

Non-Qualifying Repairs

Non-US specification vehicles, ineligible vehicles, eligible vehicles operated and repaired outside the United States and Puerto Rico and/or the diagnosis and repair of other unrelated issues are not covered under the terms of this limited warranty extension.

Qualifying Repairs - Claim Submission

Claim this work with the defect code and the labor operation provided below that applies as needed.

Defect Code:	11 15 90 48 00
---------------------	-----------------------

Cylinder Bank 1 – 4 Only

Labor Operation:	Labor Allowance:	Description:
00 62 019	Refer to KSD2	Replacing engine ventilation line on cylinders 1 – 4 (includes connecting an approved battery charger/power supply, performing a vehicle test and the required test module) (Main work)
Or:		
00 62 571	Refer to KSD2	Replacing engine ventilation line on cylinders 1 - 4 (includes connecting an approved battery charger/power supply, performing a vehicle test and the required test module) (Plus Work – Vehicle already in the workshop)

Or:

Cylinder Bank 5 – 8 Only

Labor Operation:	Labor Allowance:	Description:
00 62 020	Refer to KSD2	Replacing engine ventilation line on cylinders 5 – 8 (includes connecting an approved battery charger/power supply, performing a vehicle test and the required test module) (Main work)
Or:		
00 62 572	Refer to KSD2	Replacing engine ventilation line on cylinders 5 - 8 (includes connecting an approved battery charger/power supply, performing a vehicle test and the required test module) (Plus Work – Vehicle already in the workshop)

Or:

Both Cylinder Banks

Labor Operation:	Labor Allowance:	Description:

00 62 021	Refer to KSD2	Replacing both engine ventilation lines (includes connecting an approved battery charger/power supply, performing a vehicle test and the required test module) (Main work)
Or:		
00 62 573	Refer to KSD2	Replacing both engine ventilation lines (includes connecting an approved battery charger/power supply, performing a vehicle test and the required test module) (Plus Work – Vehicle already in the workshop)

And, as necessary:

Sublet – Bulk Materials

Sublet Code 4	See sublet reimbursement calculation below	Reimbursement for the used quantities of required bulk operating fluids (applicable BMW part numbers. Please do not use these part numbers for claim submission)
---------------	--	--

Sublet calculation: Reimbursement for used quantities of required operating fluids and materials (applicable BMW part numbers) at dealer net plus handling.

Enter this material cost in sublet and itemize the amount in the claim comment section.

Overlapping Labor – Associated and/or Other Repairs

When this repair work is being performed with other repair work and if claiming the corresponding labor operations result in overlapping labor, invoice and claim work time labor operation 00 50 000 for the “additional time (FRU)” to perform this repair instead (minus the overlap).

On the repair order and in the claim comment section, please identify the labor operations that labor operation code 00 50 000 replaces and itemize the claimed FRU amount.

Work time labor operation code 00 50 000 is not considered a Main labor operation.

Associated Repairs: When work time labor operation 00 50 000 is used as an extension of the repair outlined in this bulletin, a separate defect code and punch time(s) are not required.

Other Repairs: When work time labor operation 00 50 000 is used for work that will be claimed under a different defect code, separate punch time(s) are required.

Previous Customer-pay Repairs – Limited Warranty Extension Reimbursement

Under this extended limited warranty, BMW of North America, LLC (“BMW NA”) will provide reimbursement for “qualifying customer-pay repairs” that were performed on an eligible vehicle prior to the release of this component-specific limited warranty extension.

Customer-pay repairs are subject to the applicable vehicle and coverage eligibility requirements, exclusions and limitations that apply to the BMW New Vehicle Limited Warranty for Passenger Cars and Light Trucks.

Requesting Reimbursement for a Previous Repair that Qualifies

Note: The reimbursement request options that follows are planned to be available on or after the week of 01/11/2016.

For a customer to request reimbursement for a “qualifying customer-pay repair” performed either by an authorized BMW center or independent repair shop located in the United States (including Puerto Rico), please have him/her submit his/her reimbursement request “online” at www.BMW-RP.com under the following reference:

- **B-ELWR 2015 Crankcase Vent Hoses 10Y120M**

Reimbursement Request Procedure

The online process is initiated by attaching/sending “PDF files” of the supporting documentation for the “prior repair.”

The website, the customer-pay reimbursement attachment to this bulletin and the soon to be mailed customer letters all provide information as to “what” documentation is needed to be supplied to support a prior repair.

Alternative methods to request reimbursement, either through the mail or by fax, are also provided.

A copy of the “Customer-pay” reimbursement attachment may be printed and provided to the customer.

Repairs that do not Qualify for Reimbursement

Repairs performed on ineligible vehicles, eligible vehicles operated and had their repair performed outside the United States and Puerto Rico and/or the diagnosis and repair of other unrelated issues.

ATTACHMENTS

View PDF attachment [B011215 Prior Customer-pay Repairs.](#)

[Copyright ©2015 BMW of North America, Inc.]