



Retail Operator / General Manager	Sales – Motorcycles	Sales – Used Motorcycles	Business Manager (F&I)	Service	Parts & Accessories	Administration
Date: May 2015		Source: BMW Motorrad USA				
Bulletin #: 32 001 15 (014)		Name: Gordon McDonnell				
		Title: Manager – Service and Technical				

BMW Motorrad USA

Service Information Bulletin

Subject: Float in Handbrake fitting

Models: S 1000 XR (K49)

Details:

When the brake system is filled with fluid for the first time in the assembly plant, a float is installed in the fluid reservoir of the handbrake fitting (see Figures 1 and 2). This float is required only for the initial, vacuum-assisted filling of the system. As long as the float remains in the reservoir it is subsequently not possible to obtain a clear reading of the brake-fluid level. In order to make it easier for the fluid level to be read correctly, the float has to be removed.

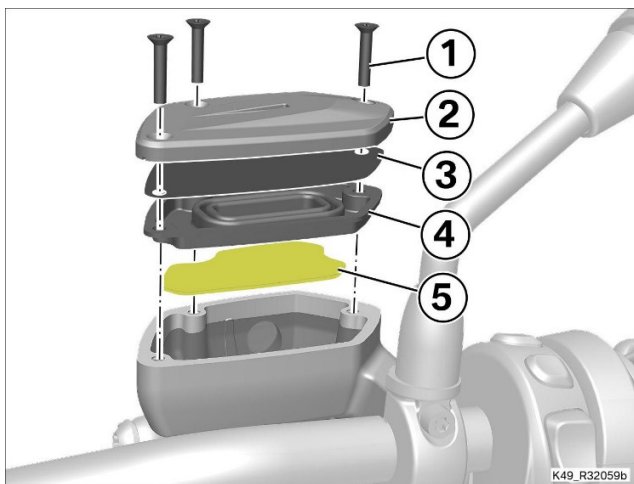

Figure 1: Components of the fluid reservoir

- Screws (1)
- Reservoir cap (2)
- Support plate (3)
- Diaphragm (4)
- Float (5)

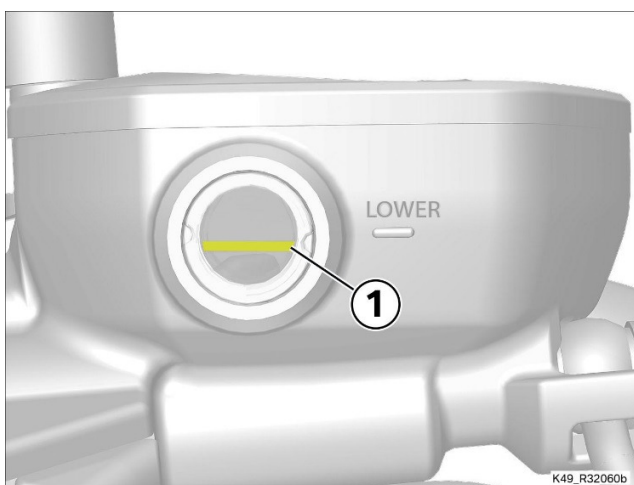

Figure 2: Sight glass of the fluid reservoir

- Float (1) (yellow)

Vehicles affected

All S 1000 XR models (K49, 0D03/0D13) as of series launch up to introduction of the modified handbrake fitting.

Production solution:

A modified handbrake fitting without a float is to be installed at the assembly plant by the end of 2015.

Aftersales solution:

Before motorcycles affected by this situation are handed over to customers, the float (5, Fig. 1) has to be removed from the fluid reservoir of the handbrake fitting. The brake-fluid level then has to be checked and, if necessary, corrected.

Warranty processing**Defect code**

32 72 90 18 00	Removing float from handbrake fitting
----------------	---------------------------------------

FRU number

32 72 325	Removing float from handbrake fitting, 2 FRUs
-----------	---

NOTICE

The closing date for invoicing under these terms is **December 31, 2015**.

Contact Information:

For technical inquires in relation to this bulletin	Please open a PuMA case
For warranty inquires in relation to this bulletin	Motorrad.Warranties@bmwna.com
For parts inquires in relation to this bulletin	Michael.Kagan@bmwnaext.com
Motorcycle Service and Technical Manager	Gordon.McDonnell@bmwna.com