



Retail Operator / General Manager	Sales – Motorcycles	Sales – Used Motorcycles	Business Manager (F&I)	Service	Parts & Accessories	Administration
Date: May 2015		Source: SI 07/2015				
Bulletin #: 61 003 15 (009)		Name: Gery Torok				
		Title: PuMA Technical Specialist				

BMW Motorrad USA

Service Information Bulletin

Technical Campaign

Subject: Fuse for voltage regulator

Models: R 1200 GS (K50, 0A01/0A11), R 1200 GS Adventure (K51, 0A02/0A12), R 1200 RT (K52, 0A03/0A13), R 1200 R (K53, 0A04/0A14), R 1200 RS (K54, 0A05)

Details: BMW Motorrad has ascertained that in isolated cases the fuse for the voltage regulator is not correctly secured in the holder by the threaded fasteners. This can prevent the battery from being charged while the motorcycle is being ridden. If this happens the 'General' warning light shows red and the battery symbol appears in the multifunction display.

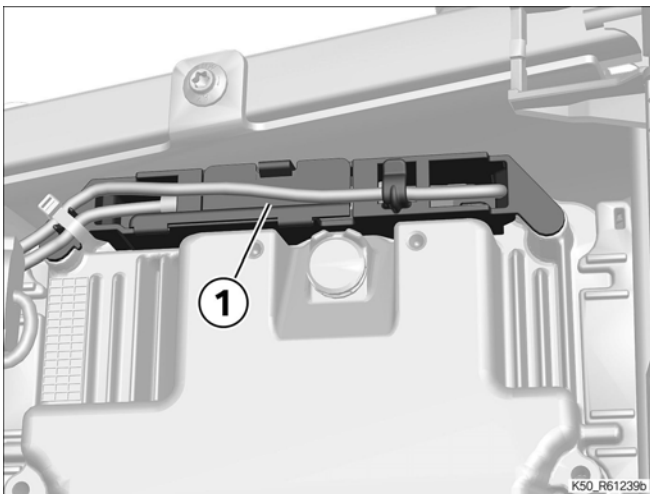

Illustration: Holder of fuse for voltage regulator (1), here R 1200 GS (K50) as example

Vehicles affected: In order to determine if a specific vehicle is affected by this Technical Campaign, it will be necessary to verify all vehicle VINs through a DCS Vehicle History Check. Based on the response of the system, either proceed with the repair or take no further action. Please note, affected VINs may not appear until 24-72 hours after the release of this bulletin.

Production Solution: Vehicles produced as of March 21, 2015 have the fuse for the voltage regulator correctly secured by the threaded fasteners.

Aftersales Solution: Before handing over a new vehicle to its owner or when vehicles possibly affected by this issue are next brought to the workshop, perform the work described in attached work item 00 60 304 Checking threaded fasteners of fuse for voltage regulator.

 **ATTENTION**
Work on components with permanent power supply (terminal 30).

Risk of short-circuit. Voltage peaks.

- Disconnect the ground lead from the battery.
- Insulate the end of the ground lead.

Warranty processing:**Defect code**

00 61 37 00 00	Checking threaded fasteners of fuse for voltage regulator
----------------	---

FRU number

00 60 304*	Checking threaded fasteners of fuse for voltage regulator, 3 FRUs
------------	---

*Main Work: This main labor operation includes all repair procedures to complete the task with allowance for necessary ancillary tasks (e.g. visual inspection, lubrication, cleaning parts etc.) and administrative tasks. Only one main labor operation can be claimed per repair visit. All other labor operations for any other line(s) must be claimed using plus code labor operations.

Please refer to the Warranty Policy and Procedures Manual regarding add-ons, proper support, documentation, claims submission and archiving requirements as applicable.

Contact Information:

For technical inquires in relation to this bulletin	Please open a PuMA case
For warranty inquires in relation to this bulletin	Motorrad.Warranties@bmwna.com
For parts inquires in relation to this bulletin	Michael.Kagan@bmwnaext.com
Motorcycle Service and Technical Manager	Gordon.McDonnell@bmwna.com

00 60 304 Checking threaded fasteners of fuse for voltage regulator

ATTENTION

Work on components with permanent power supply (terminal 30).

Risk of short-circuit. Voltage peaks.

- Disconnect the ground lead from the battery.
- Insulate the end of the ground lead.

1

► **Preparatory work**

- Removing rear seat
- Removing front seat
- Removing battery cover
- Disconnecting battery

2

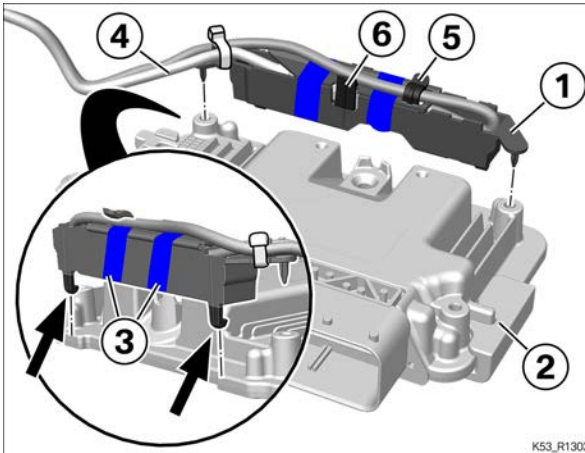

► **Disengaging holder of fuse for voltage regulator**

- Carefully bend back the hooks (**arrows**).
- Disengage holder (**1**) from engine control unit (**2**).
- Remove adhesive tape (**3**).
- Disengage cable (**4**) from holder (**5**).
- Disengage hook (**6**) and open the cover of holder (**1**).

3

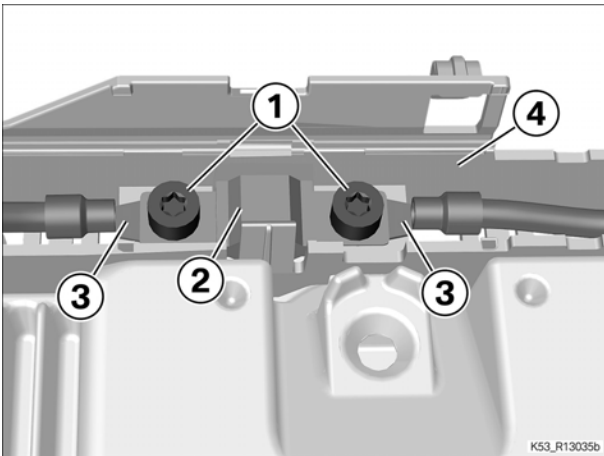

► Checking threads in holder of fuse for voltage regulator

Check

- Remove screws (1).
- Remove fuse (2) and disengage cable shoes (3) from holder (4).
- Carefully **clean** all traces of paint off all the components.
- Install screws (1) **by hand** in holder (4) and remove them again by hand.

Result

Screws (1) can be screwed in and removed **without sticking in the threads**.

Measure

- Reinstall fuse (2).

Result

Screws (1) stick or are difficult to turn: threads in holder (4) are defective.

Measure

- Replace holder (4) complete with screws (1).



4

► Replacing holder of fuse for alternator regulator

Requirement

Battery is disconnected.

- Cut open the cable tie (**arrow**) and replace holder (4).

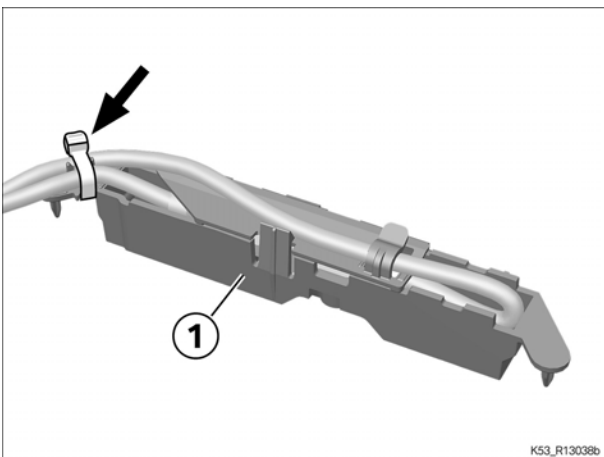

5

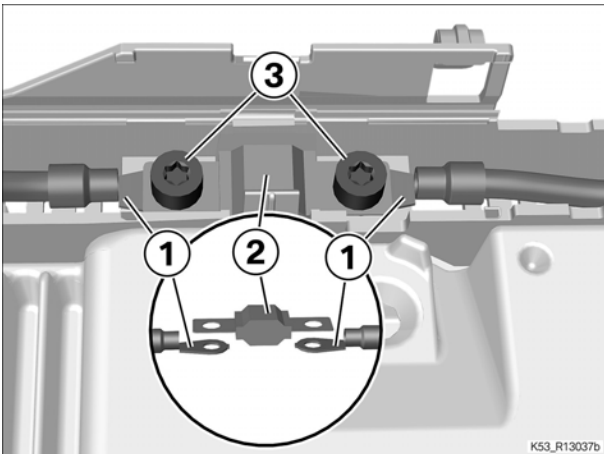

► Installing fuse for voltage regulator

- Secure cable shoes (1) and fuse (2) with screws (3), noting the correct positioning of the components.

Tightening torques		
Fuse for voltage regulator to holder		
M5 x 8 - 10.9	3.5 Nm	

Technical data			
Fuse holder	Fuse 1: Voltage regulator	50 A	

6

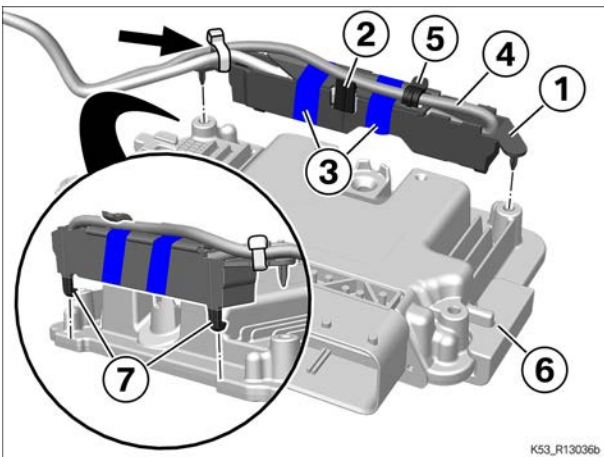

► Securing holder of fuse for voltage regulator

- Close cover of holder (1) (hook (2) engages) and wrap in adhesive tape (3).

NOTICE

Apply adhesive tape at the locations of the threaded fasteners of the fuse. The threaded bushes must be covered.

- Engage cable (4) in holder (5) and if applicable secure with a cable tie (arrow).
- Secure holder (1) to engine control unit (6).
 - » Hooks (7) engage.

7

► Finishing work

- Connecting battery
- Install the battery cover
- Checking, if necessary correcting date
- Installing front seat
- Installing rear seat