



This Service Information bulletin supersedes SI B16 01 04 **dated March 2004.**

**NEW** designates changes to this revision

#### SUBJECT

**NEW** E46 SULEV (PZEV) Fuel Tank: Pre-Disposal Procedure

#### MODEL

**NEW** E46 (3 Series with the M56 engine)

#### **NEW** INFORMATION

E46 (3 Series with the M56 engine) vehicles, in addition to meeting the SULEV (Super Ultra Low Emission) tailpipe emission standard, also conform to the Partial Zero Evaporative Emissions (PZEV) Standard.

To meet these strict standards, these vehicles have fuel tanks constructed of high-grade stainless steel which are completely sealed.

#### **NEW** SITUATION

BMW NA is **not** requesting that these fuel tanks be returned to the Warranty Parts Return Center (WPRC) after a claim payment.

#### PROCEDURE

**NEW** When performing a fuel tank replacement on an E46 “3 Series with the M56 SULEV (PZEV) engine” (claim and non-claim related), the following pre-disposal procedure must be performed prior to scrapping the fuel tank.

**BEFORE STARTING AND WHILE CONDUCTING THE STEEL FUEL TANK DISPOSAL PROCEDURE, FOLLOW ALL LOCAL AND STATE LAWS AND REGULATIONS PERTAINING TO HANDLING OF FLAMMABLE LIQUIDS.**

**DO NOT USE ANY ELECTRICALLY POWERED TOOLS OR OPEN-FLAME DEVICES (E.G., ACETYLENE TORCHES) DURING THIS PROCEDURE.**

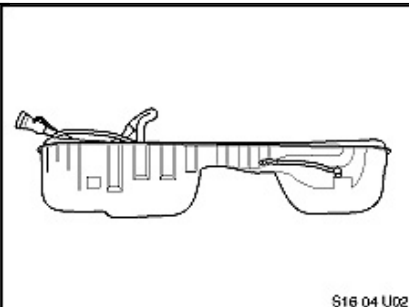
 <p style="text-align: right; font-size: small;">S16 04 U02</p>	<ol style="list-style-type: none"> <li>1. As a safety precaution, when handling fuel tank always wear safety goggles and plastic (not latex) gloves, Nitrile preferred.</li> <li>2. Remove defective fuel tank from the vehicle and place it on a workbench in an area where good ventilation is provided.</li> </ol>
	<ol style="list-style-type: none"> <li>3. To prevent fuel vapors from escaping from the tank, use the plastic covers from the replacement tank to plug the filler neck and the filler vent line.</li> </ol>

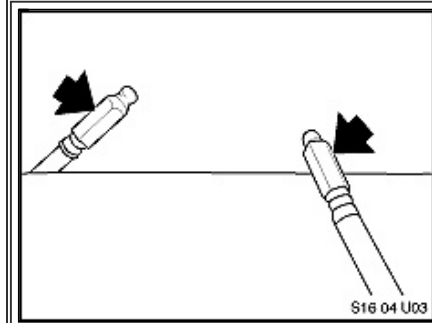
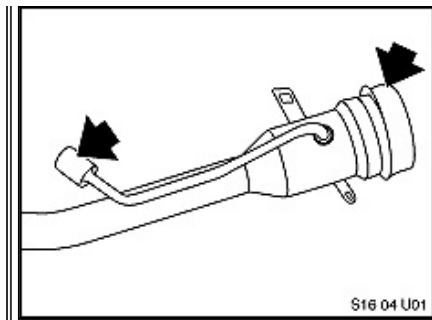

4. Also use the plastic covers from the replacement tank to plug the fuel outlet line and tank vent line.

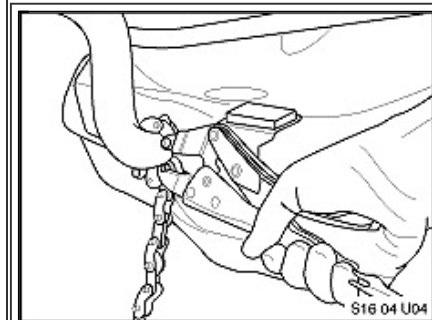

5. Using a good quality pipe cutter (e.g. Exhaust Pipe Cutter PN 90 88 6 002 210), cut the fuel fill pipe at approximately 1" from the tank.

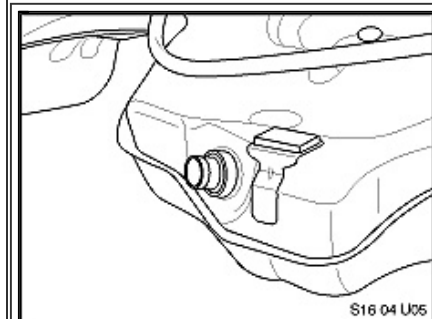

6. Dispose stainless steel fill pipe.

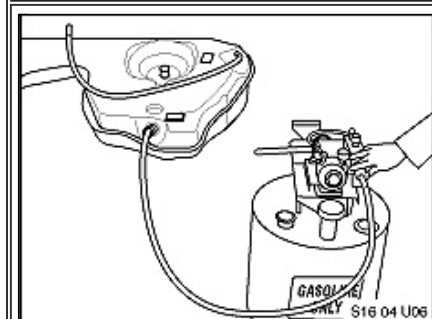

7. Using an air or hand-operated , portable fuel transfer system (e.g. Tempo 30-FM-3200-GA listed in 2002 BMW Equipment Program Catalog), evacuate all fuel from the right side of the tank through the fill pipe inlet.

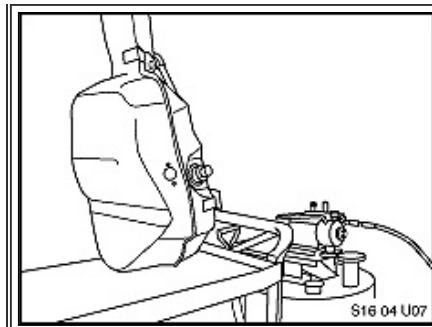

8. Carefully lift up the left side of the tank to allow fuel transfer to the right half of the tank (the one with filler inlet).
9. Again, remove all remaining fuel using the air-operated fuel transfer pump system.

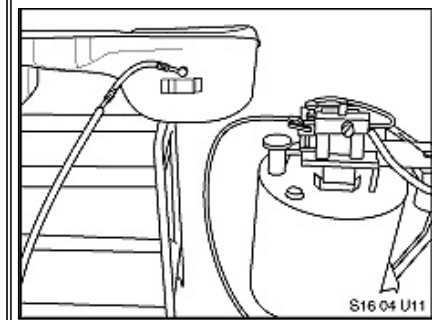

10. Evacuate all fuel remaining in the fuel filter and outlet line by connecting the air-operated transfer pump to the tank output line.

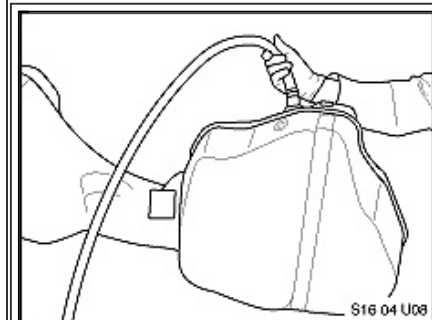

11. After all the fuel has been evacuated, place the tank in an upright position (filler inlet up) and fill it with water until water starts overflowing from the filler neck.

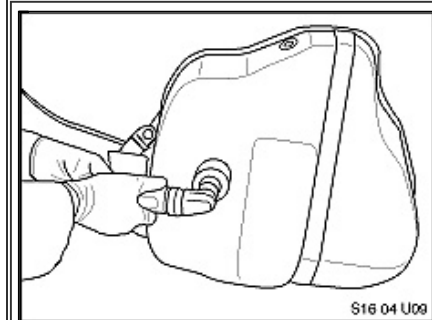

12. Maintaining tank's upright position and full water content, using an air-powered drill with a 2 1/2" hole saw drill a hole at the bottom side of the tank (on the filler inlet side).

**DO NOT USE ANY ELECTRICALLY POWERED CUTTING DEVICES.**

Dispose water in accordance to the local and state laws and regulations.

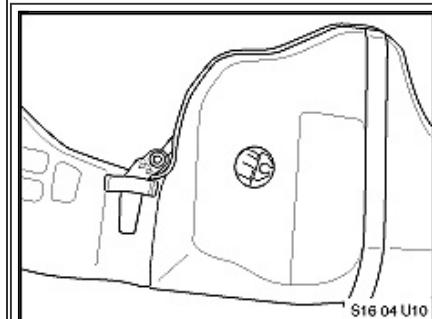

13. After cutting the filler pipe and drilling the opening in the bottom, the fuel tank does not pose any environmental threat and may be safely scrapped.

---

**WARRANTY INFORMATION**

Not applicable.

[ Copyright ©2015 BMW of North America, Inc. ]