

Retail Operator General Manager	Sales New Motorcycles	Sales Pre-Owned Motorcycles	Business Manager (F&I)	Service	Parts & Accessories	Administration
Date:	December 2014	Source:	SI 33/2014			
Bulletin #	32 001 14 (045)	Name:	Shawn McLean			
		Title:	Service & Technical Manager			
		Phone:	201-307-4131			



# BMW Motorrad USA

## Service Information Bulletin

### **\*\*Technical Campaign\*\***

**Subject:** Clutch Lever Fitting

**Model:** S 1000 R (K47) with the cruise control optional extra (OE 0538)

**Details:** In the framework of quality monitoring, BMW Motorrad has ascertained that in some cases the clutch switch can trip before the clutch has fully disengaged. This is due to an incorrect cam-lobe contour on the clutch lever.  
For this reason, as of May 2014 the switch had been modified in such a way as to correct the switching point. Subsequently installing a clutch lever with the correct cam-lobe contour on one of these vehicles would change the switching point outside the tolerance window.

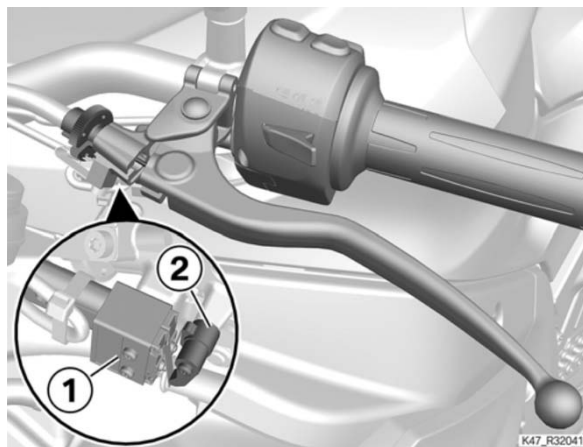

Illustration: Clutch lever fitting

- Microswitch (1)
- Cam lobe (2)

**Vehicles affected:** In order to determine if a specific vehicle is affected by this Technical Campaign, it will be necessary to verify all vehicle VINs through a DCS Vehicle History Check. Based on the response of the system, either proceed with the repair or take no further action. Please note, affected VINs may not appear until 24-72 hours after the release of this bulletin.

**Production Solution:** As of September 19, 2014, clutch lever fittings with the correct cam-lobe contour have been installed in series production.

**Aftersales Solution:** The vehicles in question will have to be checked and the complete clutch lever fitting replaced (see attached work item 00 60 299) either before the new vehicles are handed over to customers or when the individual vehicles are next brought in to the workshop. In the case of vehicles fitted with a hinged clutch lever (optional accessory), the clutch lever assembly has to be replaced and the clutch lever modified accordingly using the cam lobe of the new clutch lever fitting.  
See the description of the applicable work item (77 22 503 Installing hinged clutch lever) on the current RSD (Repair and Service Data BMW Motorrad) DVD.

**Warranty:** The repair described in this bulletin is covered under warranty regardless of time or mileage. Reimbursement for this Technical Campaign is through normal claim entry utilizing the following information:

**Warranty Processing Information:** Defect code: 00 32 11 00 00 Replacing clutch lever fitting  
FRU code: 00 60 299\* Replacing handlebar fitting for clutch actuation, 4 FRUs

and if hinged lever is fitted

+77 22 503 Installing hinged clutch lever, 1 FRUs

Part number: 32 72 8 556 787 Clutch lever fitting (for vehicles with cruise control)

\*Main Work 00 60 299 - this main labor operation crediting 4 FRUs includes all repair procedures to complete the task with allowance for necessary ancillary tasks (e.g. visual inspection, lubrication, cleaning parts etc.) and administrative tasks.

Only one main labor operation can be claimed per repair visit. All other labor operations for any other line(s) must be claimed using plus code labor operations.

Please refer to the Warranty Policy and Procedures Manual regarding add-ons, proper support, documentation, claims submission and archiving requirements as applicable

**Contact:** Service and Technical Manager

– with cruise control<sup>OE</sup> (0538)

## 1

### ► Preparatory work

- Installing rear-wheel stand
- Disengaging clutch cable
- Disconnecting plug for clutch switch
- Removing mirror

## 2

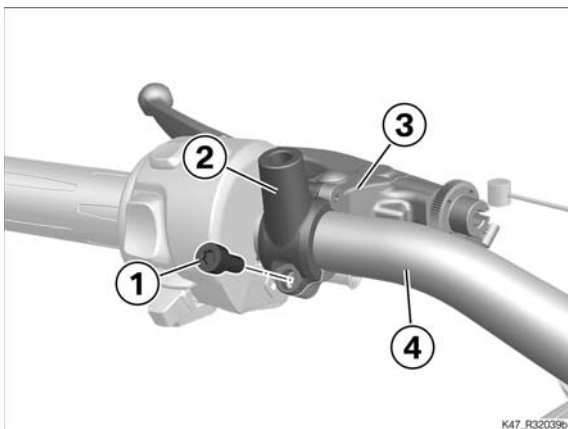

### ► Removing clutch lever fitting

- Remove screw (1).
- Flip open clamp (2) and remove clutch lever fitting (3) from handlebar (4).

## 3

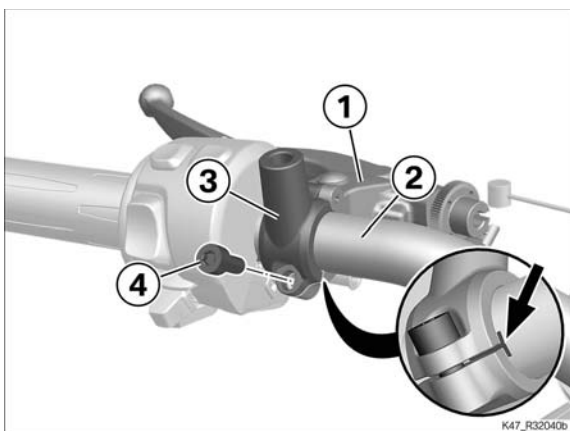

### ► Installing clutch lever fitting

- Hold clutch lever fitting (1) in position on handlebar (2) and close clamp (3).
- Loosely install screw (4).
- Align clutch lever fitting (1) with the mark (arrow) and tighten screw (4).

Tightening torques	
Clutch lever fitting to handlebar	
M6 x 15	8 Nm

## 4

### ► Finishing work

- Installing mirrors
- Connecting plug connection for clutch switch
- Secure the clutch cable
- Checking/adjusting clutch-lever play
- Checking switching point of clutch switch
- Lubricating clutch mechanism
- Removing rear-wheel stand
- Final check of work performed