



NUMBER: 22-002-15 REV. A

GROUP: Tires and wheels

DATE: March 28, 2015

This bulletin is supplied as technical information only and is not an authorization for repair. No part of this publication may be reproduced, stored in a retrieval system, or transmitted, in any form or by any means, electronic, mechanical, photocopying, or otherwise, without written permission of FCA US LLC.

THIS BULLETIN SUPERSEDES SERVICE BULLETIN 22-002-15, DATED FEBRUARY 20, 2015, WHICH SHOULD BE REMOVED FROM YOUR FILES. THIS IS A COMPLETE REVISION AND NO ASTERISKS HAVE BEEN USED TO HIGHLIGHT REVISIONS.

THIS SERVICE BULLETIN IS ALSO BEING RELEASED AS RAPID RESPONSE TRANSMITTAL (RRT) 15-020, ALL APPLICABLE SOLD AND UN-SOLD RRT VIN'S HAVE BEEN LOADED. TO VERIFY THAT THIS RRT SERVICE ACTION IS APPLICABLE TO THE VEHICLE, USE VIP OR PERFORM A VIN SEARCH IN TECHCONNECT. ALL REPAIRS ARE REIMBURSABLE WITHIN THE PROVISIONS OF WARRANTY.

SUBJECT:

Service Tire Pressure System Message

OVERVIEW:

This bulletin involves replacing all of the Tire Pressure Module (TPM) sensors.

MODELS:

2014-2015	(DJ)	Ram 2500 Pickup
2014-2015	(D2)	Ram 3500 Pickup
2014-2015	(DD)	Ram 3500 Cab Chassis

NOTE: This bulletin applies to vehicles built on or before November 05, 2014 (MDH 1105XX).

SYMPTOM/CONDITION:

The customer may notice a message "Service Tire Pressure System" displayed on the cluster. On further inspection, the technician may find one or more of the following Diagnostic Trouble Codes (DTCs):

NOTE: The cluster will always display the low tire indicator if the tire pressure is under specification, or if there is a DTC set in the TPM system. If a DTC is set, the indicator will flash for 75 seconds, and then stay on solid when the vehicle is started.

- C1501-07 Tire Pressure Sensor 1 - Mechanical Failure.
- C1501-31 Tire Pressure Sensor 1 - No Signal.
- C1502-07 Tire Pressure Sensor 2 - Mechanical Failure.
- C1502-31 Tire Pressure Sensor 2 - No Signal.
- C1503-07 Tire Pressure Sensor 3 - Mechanical Failure.
- C1503-31 Tire Pressure Sensor 3 - No Signal.
- C1504-07 Tire Pressure Sensor 4 - Mechanical Failure.
- C1504-31 Tire Pressure Sensor 4 - No Signal.

DIAGNOSIS:

Using a Scan Tool (wiTECH) with the appropriate Diagnostic Procedures available in TechCONNECT, verify no DTCs are set. If DTCs or symptom conditions other than the ones listed above are present, record the issues on the repair order and repair as necessary before proceeding further with this bulletin.

If a customer's VIN is listed in VIP or your RRT VIN list, perform the repair. For all other customers that describe the symptom/condition or if the technician finds any of the DTCs listed above, perform the Repair Procedure.

PARTS REQUIRED:

(Refer to Star Parts for application usage.)

Qty.	Part No.	Description
AR	68249197AA	Sensor, Tire Pressure
AR	68249200AA	Sensor, Tire Pressure
AR	68249201AA	Sensor, Tire Pressure

SPECIAL TOOLS/EQUIPMENT REQUIRED:

9936	TPM-RKE Analyzer Tool
------	-----------------------

REPAIR PROCEDURE:

1. Replace **all** of the TPM sensors.
2. Raise and support the vehicle, follow the procedure in TechConnect, 04 - Vehicle Quick Reference / Hoisting/Standard Procedure.
3. Remove all of the tires from the vehicle.
4. Deflate the tires completely before breaking loose the top bead **ONLY**.

NOTE: Mark the tire and wheel assembly with tire chalk to insure the tire and wheel are reassembled in the correct orientation.

5. When breaking the tire bead loose from the wheel/rim, avoid using the Bead Breaker in the area of the sensor.
6. Pry down on the tire sidewall to gain access to the tire pressure sensor.
7. Does the sensor have a rubber valve stem?
 - a. Yes >>> Proceed to [Step #8](#).
 - b. No >>> Proceed to [Step #19](#).
8. Remove the sensor to valve retainer screw and remove the sensor from the rim.

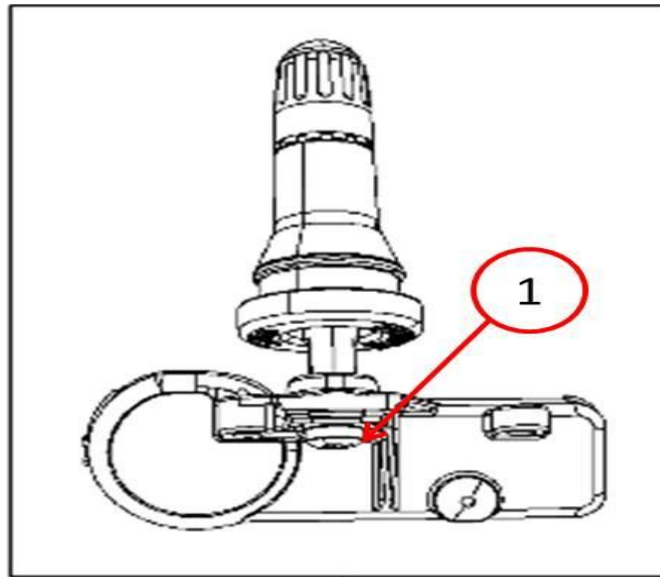

Fig. 1 Rubber Valve Stem

1 - Retaining Screw Location

9. Remove the rubber valve from the rim.
10. Clean valve stem mounting surface and install the new rubber valve stem on the rim.
11. Attach a new sensor to the valve stem using a new retainer screw and tighten to 1.4 N·m (12 in. Lbs.) (Fig. 1).
12. Clean tire bead and rim. Lube tire bead with proper tire soap/lube.

CAUTION: Tire pressure sensor valve stem caps and cores are specially designed for the sensors. Due to risk of corrosion, do not use a standard valve stem cap or core in a tire pressure sensor in place of the original equipment style sensor cap and core.

13. To help avoid damaging the sensor, pull tire bead up and away from the sensor before inflating.
14. Inflate tires and adjust air pressure to that listed on the Tire Inflation Pressure Label (Placard) provided with vehicle (usually applied to driver's side B-pillar).
15. Install tire and wheel assembly on the vehicle.
16. Tighten lug nut M14 to (2500, 3500) 203 N·m (150 Ft, Lbs.) or lug nut M14 with flat washer to (3500) 196 N·m (145 Ft. Lbs.).
17. Remove the support and lower the vehicle.
18. Program the new sensor ID and location, proceed to [Step #28](#).
19. Remove retaining nut from metal valve stem and remove valve/sensor from the rim.

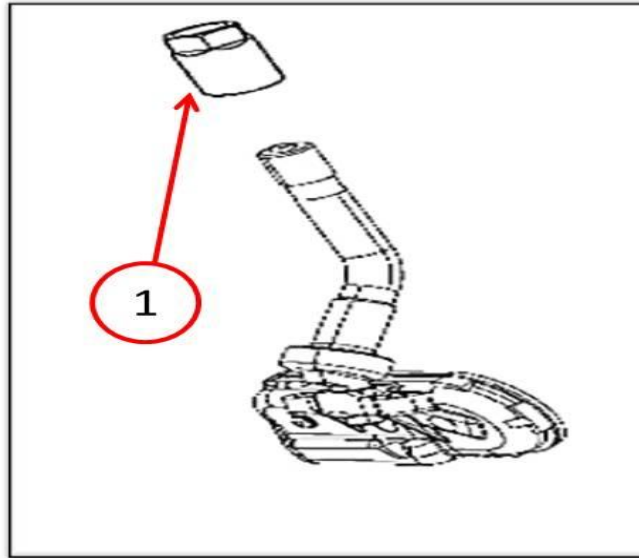

Fig. 2 Steel Valve Stem and Retaining Nut

1 - Retaining Nut

-
20. Clean valve stem mounting surface and install new sensor with metal valve stem onto the rim.
 21. Install and tighten new valve stem retainer, tighten to 12 N·m (106 in. lbs.) (Fig. 2).
 22. Clean tire bead and rim. Lube tire bead with proper tire soap/lube.

CAUTION: Tire pressure sensor valve stem caps and cores are specially designed for the sensors. Due to risk of corrosion, do not use a standard valve stem cap or core in a tire pressure sensor in place of the original equipment style sensor cap and core.

23. To help avoid damaging the sensor, pull tire bead up and away from the sensor before inflating.
24. Inflate tires and adjust air pressure to that listed on Tire Inflation Pressure Label (Placard) provided with vehicle (usually applied to driver's side B-pillar).
25. Install tire and wheel assembly on the vehicle.
26. Tighten lug nut M14 to (2500, 3500) 203 N·m (150 Ft, Lbs.) or lug nut M14 with flat washer to (3500) 196 N·m (145 Ft. Lbs.).
27. Remove the support and lower the vehicle.

NOTE: The RKE-TPM Analysis Tool CH9936 MUST BE UPDATED to the most recent version prior to use. Versions earlier than 15.04 could either give a no response to the Read command OR display incorrect TPM Sensor IDs that can lead to false DTCs.

28. Using the TPM-RKE Analyzer Tool, select TPM Functions, then enter the Model Year and the Body Style of the vehicle, and for the Trigger Selection select LEARN ID.

NOTE: If a TPM-RKE Tool is not available, let the vehicle sit stationary for more than 20 minutes, and then drive the vehicle for a minimum of 10 minutes while maintaining a continuous speed above 24 km/h (15 mph).

- 29. Scan each TPM sensor at each road wheel, and record each TPM sensor ID and the location of that sensor.
- 30. In wiTech go to the TPM section, select Misc Function, then Program Tire sensor ID.
- 31. Enter each sensor ID in its proper location.
- 32. Clear any DTCs that may have been set in any module due to this repair procedure.

POLICY:

Reimbursable within the provisions of the warranty.

TIME ALLOWANCE:

Labor Operation No:	Description	Skill Category	Amount
22-14-01-94	Sensor, Tire Pressure (TPM) - Replace Four (1 - Semi-Skilled)	4 - Chassis Systems	1.2 Hrs.
22-14-01-95	Sensor, Tire Pressure (TPM) - Replace Six (1 - Semi-Skilled)	4 - Chassis Systems	1.6 Hrs.

FAILURE CODE:

ZZ	Service Action
----	----------------