



Countries:	AUSTRALIA, CANADA, UNITED STATES, NEW ZEALAND	Document ID:	IK1201124
Availability:	ISIS, FleetSIS	Revision:	3
Major System:	ENGINES	Created:	5/20/2014
Current Language:	English	Last Modified:	8/12/2015
Other Languages:	NONE	Author:	Ben Krejcie
Viewed:	6580		

[Less Info](#)

Hide Details

Coding Information

Copy Link 	Copy Relative Link 	Bookmark View My Bookmarks	Add to Favorites 	Print 	Provide Feedback 	Helpful 28	Not Helpful 1
----------------------	-------------------------------	--	-----------------------------	------------------	-----------------------------	--------------------------	-----------------------------

Title: Induction System Cleaning Procedure

Applies To: 2010 MaxxForce 11/13, N13 engines

CHANGE LOG

- 2015/08/12 - Updated link in diagnostics steps
- 2015/02/11 - Fixed idle time for valve bridge falling off during procedure (from "x" to 2 minutes)
- 2014/12/10 - Added O2 and NOx sensor plug information, updated format, added "Procedure Overview" with important information
- 2014/05/28 - Initial article release

DESCRIPTION

There are instances of prior component failures causing coking/build-up in the cylinder heads of 2010+ Emissions MaxxForce 11/13L engines. The build-up can stick the intake valves closed, resulting in poor performance and misfire, typically as a result of the bridge falling off. Prior repairs required cylinder head replacement; however the new Induction Cleaning Tool will allow for a much quicker and less intrusive repair. The following document is for tool usage and procedure--all symptoms are listed as reference and diagnostics should be completed through the appropriate fault code action plans.

SYMPTOMS

Diagnostic Trouble Codes & Dashboard Indicator Lights:

DTC/Light	Description
SPN 731 FMI 16	Engine Knock Detected : Unexpected Fueling Without Demand
SPN 1322 FMI 31	Misfire - Multiple Cylinder
SPN 1323 FMI 31	Misfire - Cylinder # 1
SPN 1324 FMI 31	Misfire - Cylinder # 2
SPN 1325 FMI 31	Misfire - Cylinder # 3
SPN 1326 FMI 31	Misfire - Cylinder # 4
SPN 1327 FMI 31	Misfire - Cylinder # 5
SPN 1328 FMI 31	Misfire - Cylinder # 6

Customer Observations or Concerns:

- Check Engine Light On
- Low Power
- Misfire

SPECIAL TOOLS

Tool Description	Tool Number	Comments	Instructions
Induction System Cleaner	12-544-01		
Induction System Cleaner ECM (PayStar)	12-544-01-18P	Only available on a Loaner Program	
Induction System Cleaner ECM (WorkStar)	12-544-01-18W	Only available on a Loaner Program	
EZ Tech (Servicemaxx)			
Plug, Oxygen Sensor	12-544-01-20		
Plug, NOx Sensor	12-544-01-21		

SERVICE PARTS INFORMATION

Kit Description	Part Number	Quantity Required	Notes
Fluid, EGR Cleaning	3015979C1	2.5 Gal	
Kit, Oil Filter	3007498C94	1	
Kit, Oil Centrifuge Filter	2606467C92	1	
Engine Oil			

PROCEDURE OVERVIEW**Review the following important notes before continuing:**

New cleaning tool kit includes plugs for the NOx and O2 sensors. These sensors will no longer be warranted for replacement as part of this procedure (once tools are received).

Inspect dipstick to verify proper oil level and inspect under oil fill cap for coolant contamination. If coolant is low, or contaminated, the oil should be changed prior to running this procedure.

Inspect for proper coolant level, if the coolant level is low or the vehicle has a history of coolant loss refer to [IK1201066](#) - Cooling System Diagnostics.

If valve bridge falls off while running the procedure, put the valve bridge back on and run the engine at **idle** while injecting fluid for two minutes. Shut the engine down and let it sit for five minutes prior to restarting the procedure (ie, let the solution sit on the valve stems and soak into the build-up).

Prior to running this procedure be sure valve bridges are installed and adjusted to specifications. The procedure can be found in the engine service manual : [Service Manual 000001682](#)

There is a video walkthrough of this procedure available through the [Learning Management System](#). To access the video in the Learning Management System select "Course Catalog," next select "Critical Repair Videos," select next to "Induction Cleaning Procedure", and enroll. After enrolling go back to "My Current Enrollments" to watch.

DIAGNOSTIC STEPS

All diagnostics should be completed through [IK1200915 - Misfire Diagnostics](#)

REPAIR STEPS

1. Bring the vehicle into shop and park on flat surface.
 2. Shift the transmission into Park or Neutral, set parking brake, and install wheel chocks.
 3. Unlatch and open the hood.
 4. Disconnect the negative battery terminal.
 5. Remove the air filter housing.
-

REMOVAL PROCEDURE

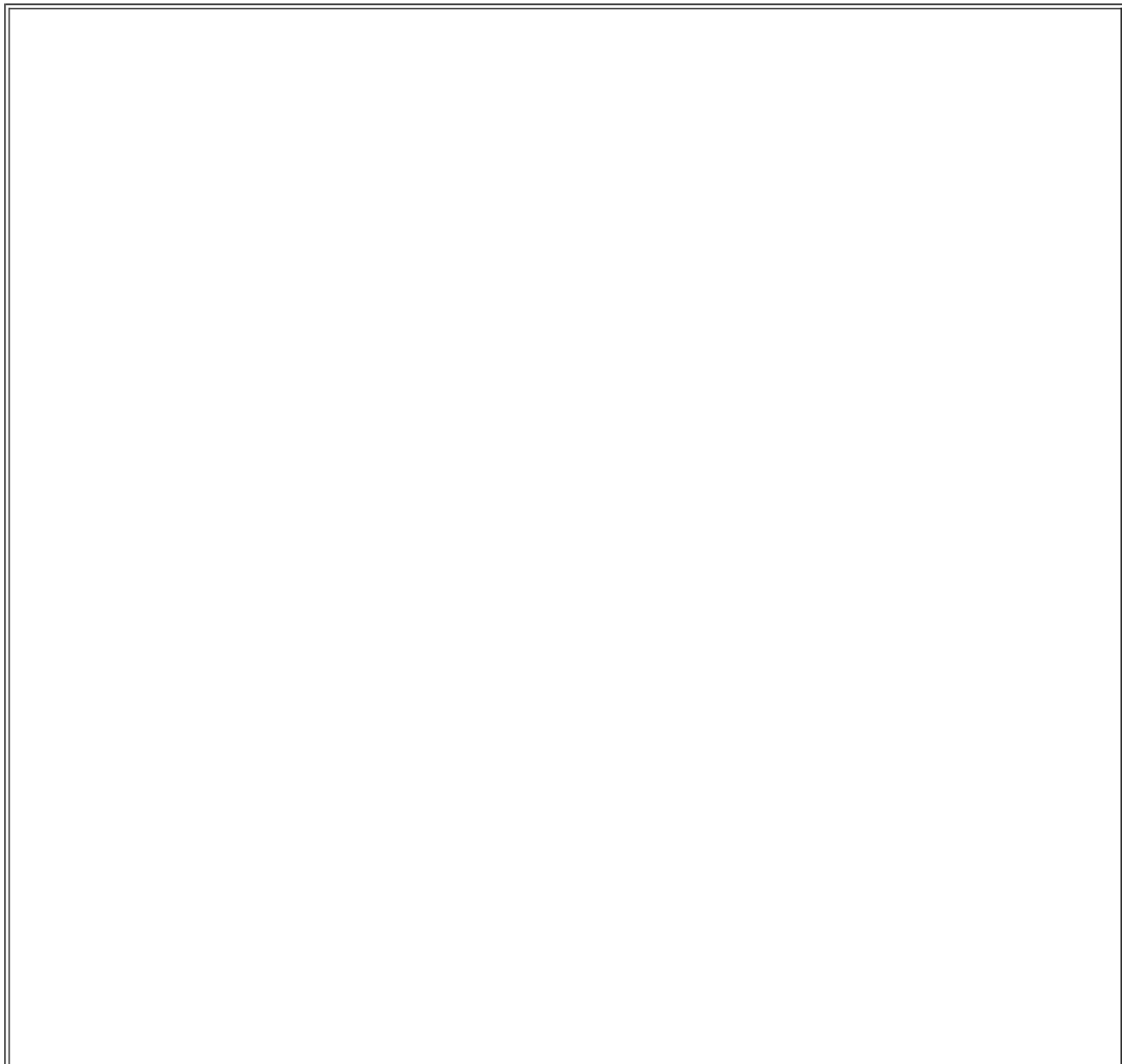

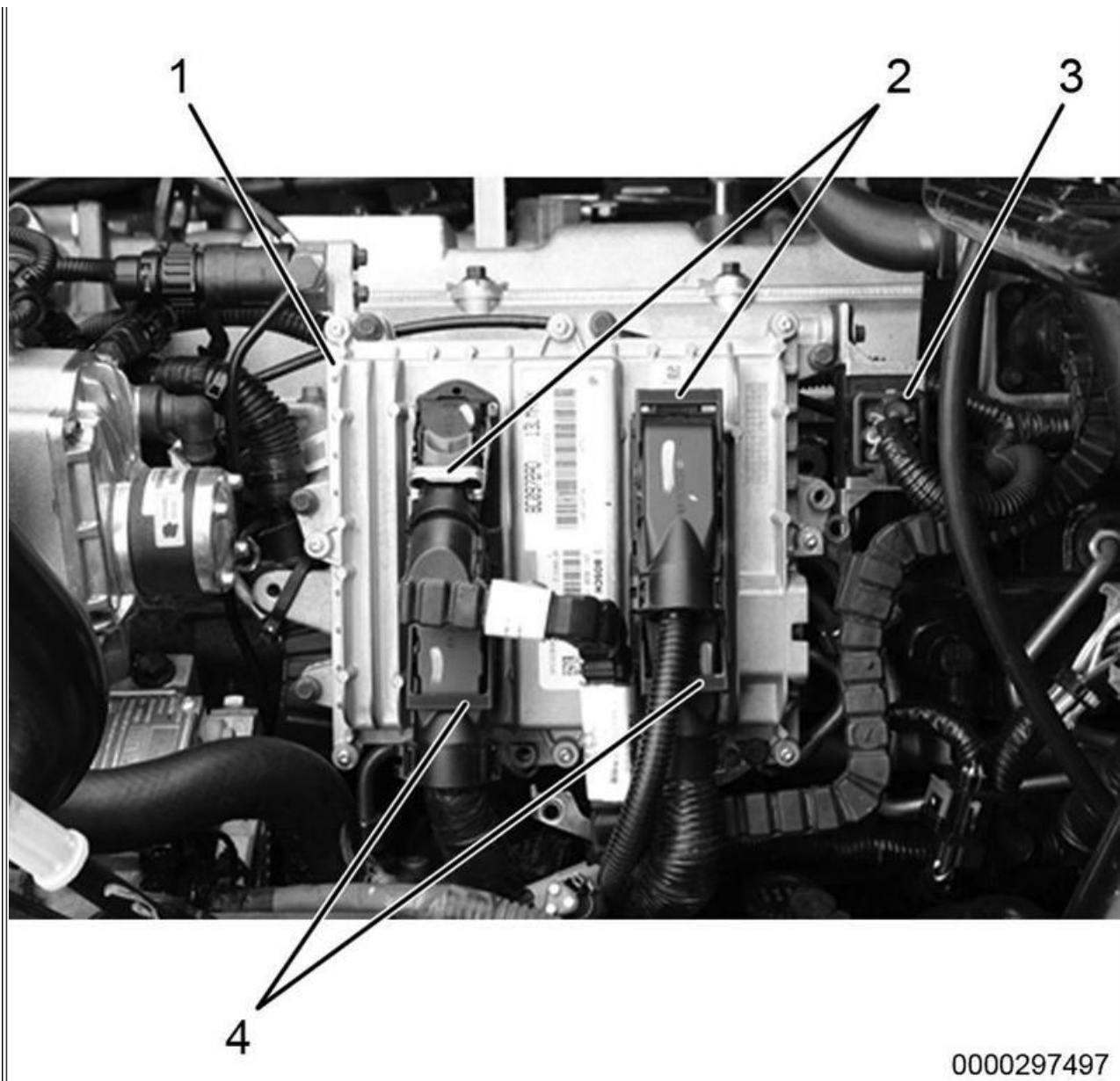

Figure 1: Electronic Control Module (ECM) Connectors

Item 1: ECM

Item 2: Upper ECM connector lock (2)

Item 3: Cold start relay

Item 4: Lower ECM connector lock (2)

6. Disengage upper connector locks (Figure 1, Item 2).
7. Disconnect upper ECM connectors.
8. Disengage lower connector locks (Figure 1, Item 4).
9. Disconnect lower ECM connectors.
10. Disconnect cold start relay connector (Figure 1, Item 3) next to ECM.
11. Remove eight bolts securing ECM. Do not discard.
12. Remove ECM (Figure 1, Item 1) from vehicle. Do not discard.

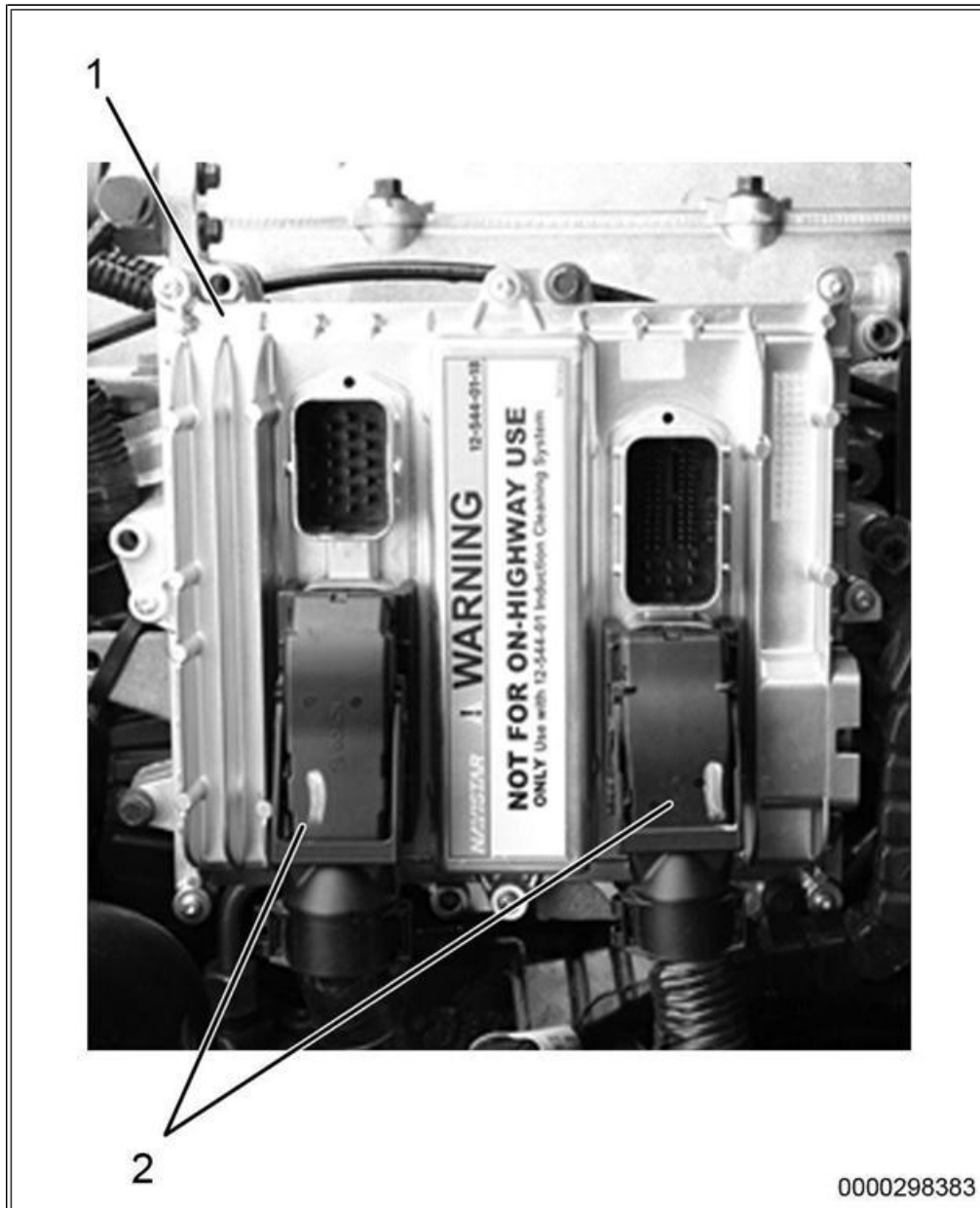

Figure 2: Test ECM

Item 1: 12-544-01-18 ECM

Item 2: Lower ECM connector (2)

13. Position and install the ECM (Figure 2, Item 1) with two of the previously removed bolts. Since the vehicle will not be driving, it is not necessary to install all bolts. Use a torque wrench to tighten bolts to 10 lb-ft (14 N•m).

14. Connect lower ECM connectors (Figure 2, Item 2) and engage connector locks.

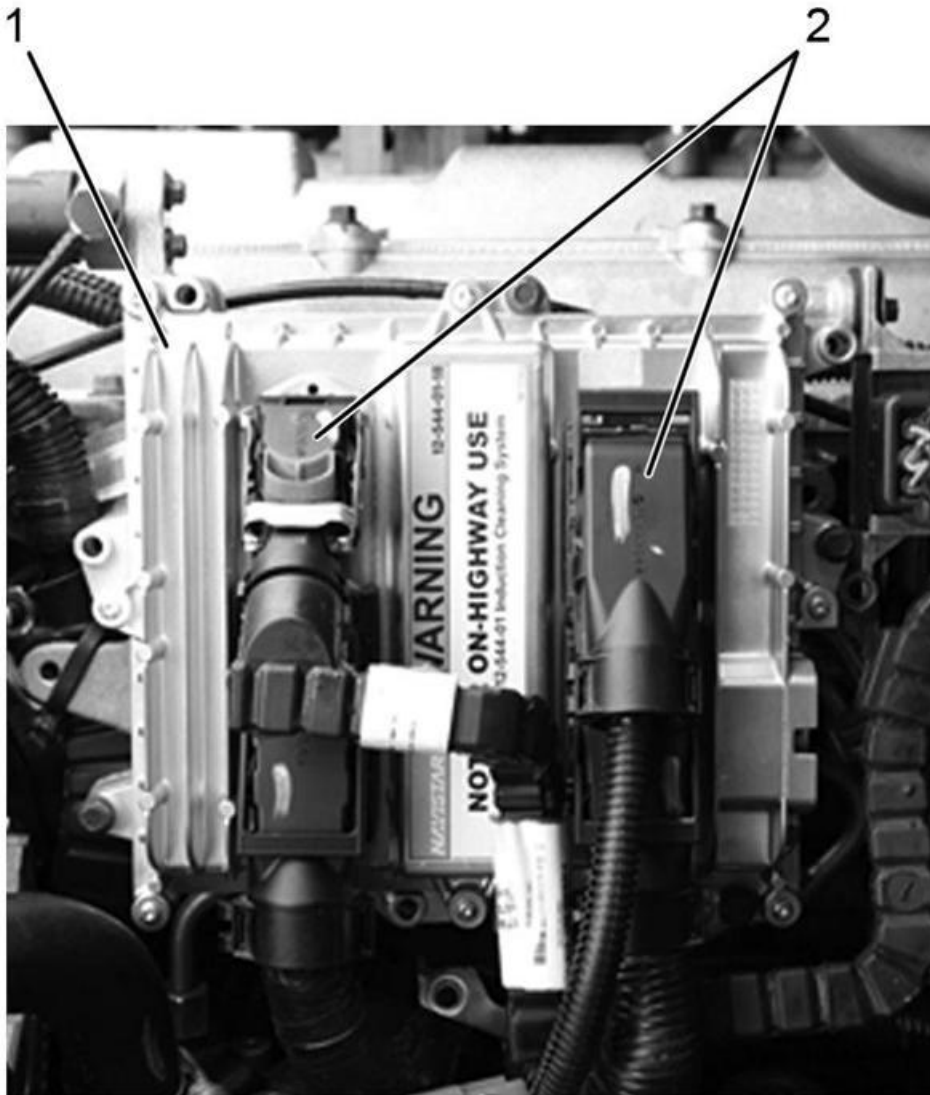

0000298382

Figure 3: Induction Cleaning ECM Upper Connectors

Item 1: 12-544-01-18 ECM

Item 2: Upper ECM connector (2)

15. Connect upper ECM connectors (Figure 3, Item 2) to induction cleaning ECM (Figure 3, Item 1), and engage connector locks.

16. Install air filter housing.

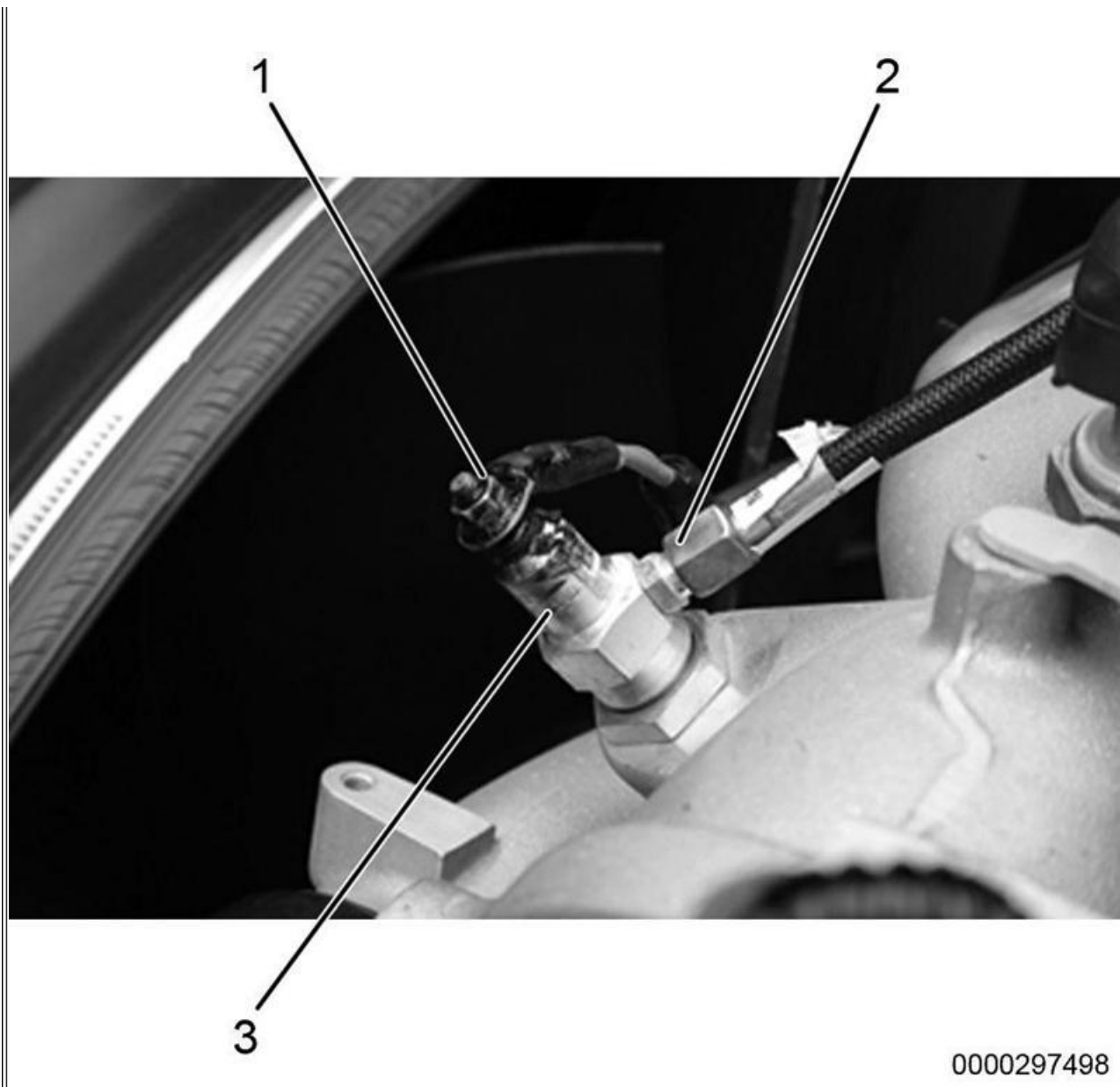

Figure 4: Cold Start Fuel Igniter

Item 1: Cold start electrical connector

Item 2: Cold start fuel supply line

Item 3: Cold start fuel igniter

17. Remove cold start fuel supply line (Figure 4, Item 2).
18. Remove cold start electrical connector (Figure 4, Item 1).
19. Remove cold start fuel igniter (Figure 4, Item 3).

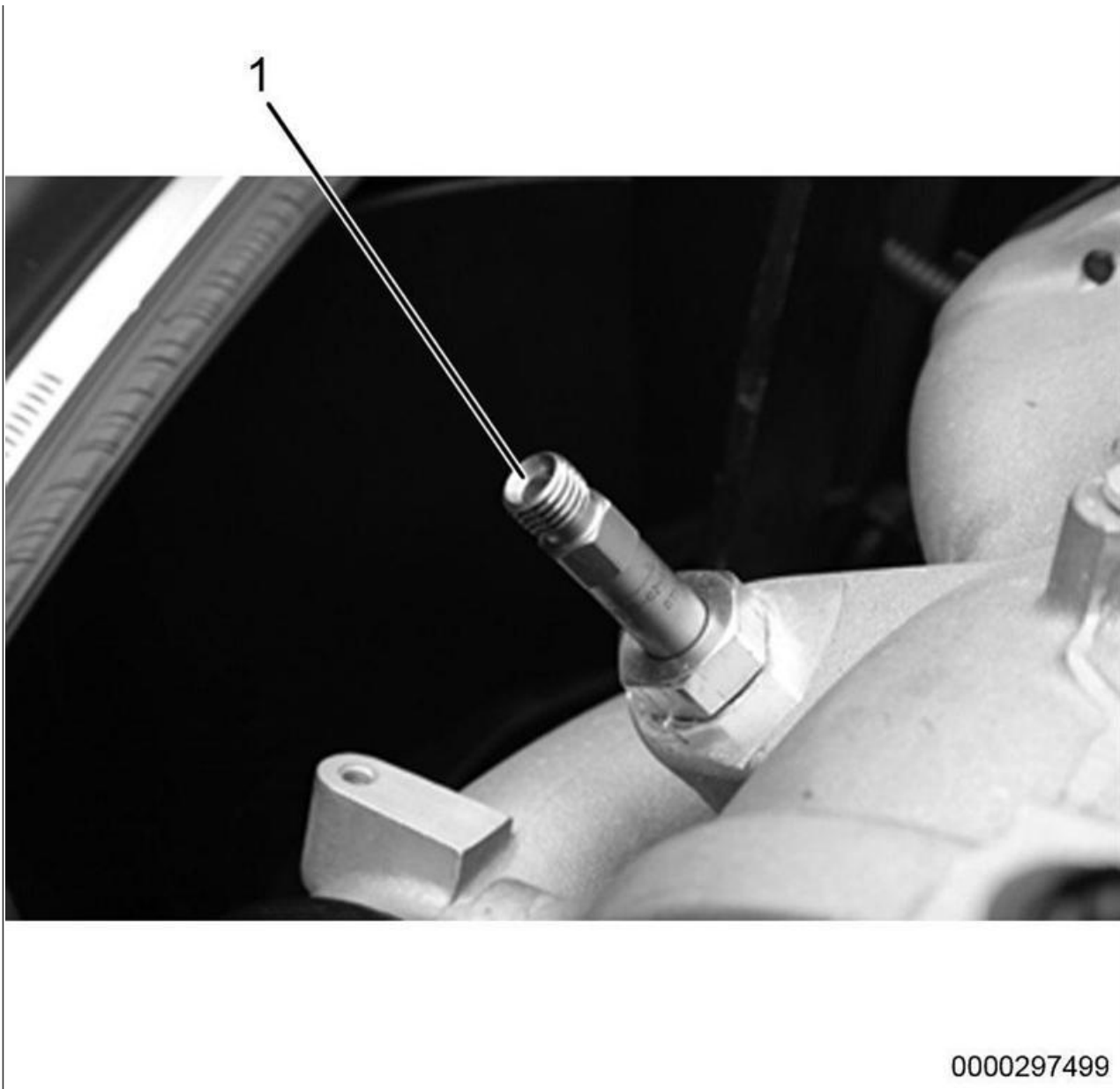

Figure 5: Injector and Adaptor

Item 1: 12-544-01-10 Injector

20. Remove protective cap, and install kit-supplied injector adapter and injector (Figure 5, Item 1) into cold start fuel igniter port. Hand tighten injector adapter but no more than 10 lb-in (1 N·m).

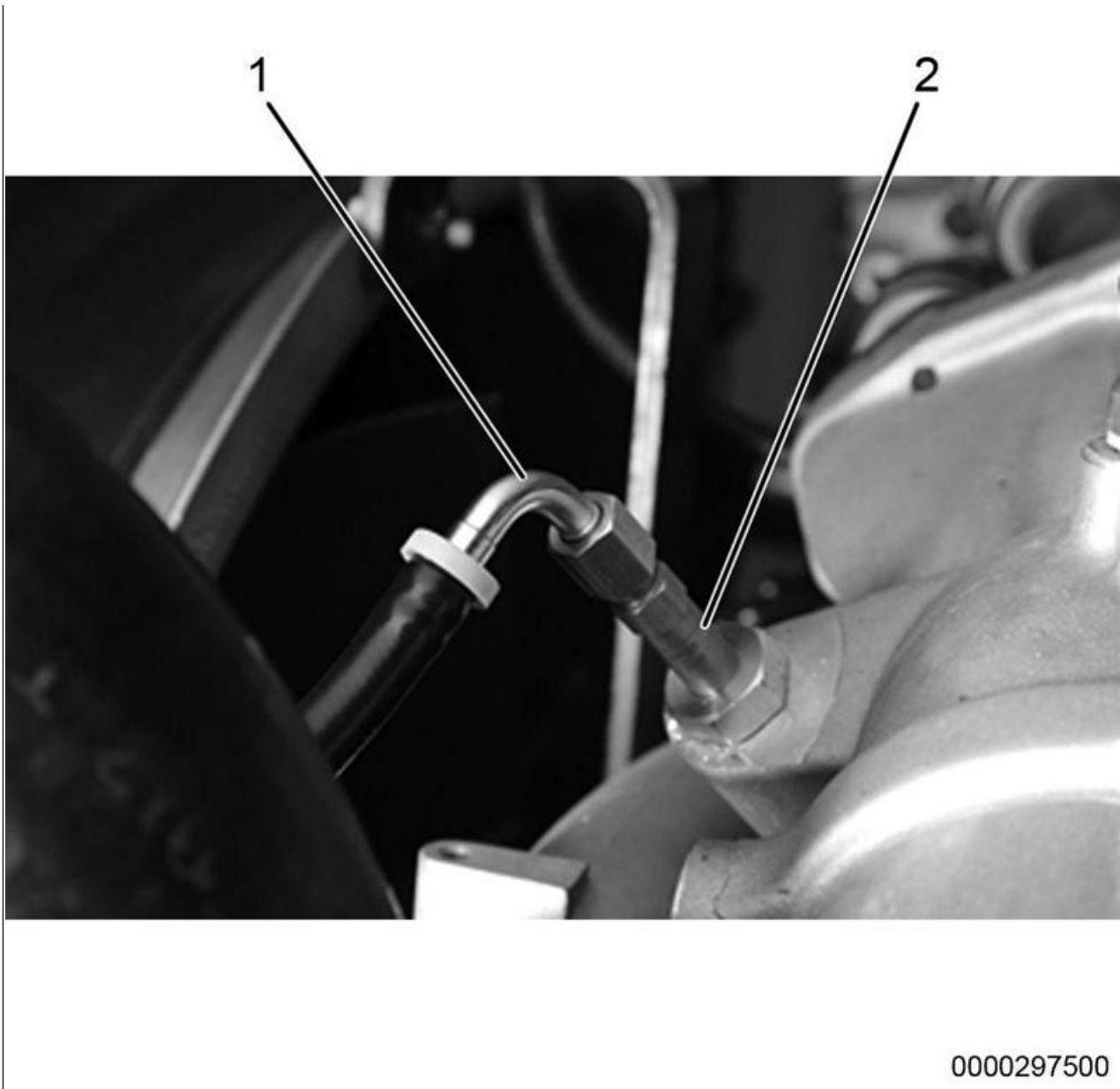
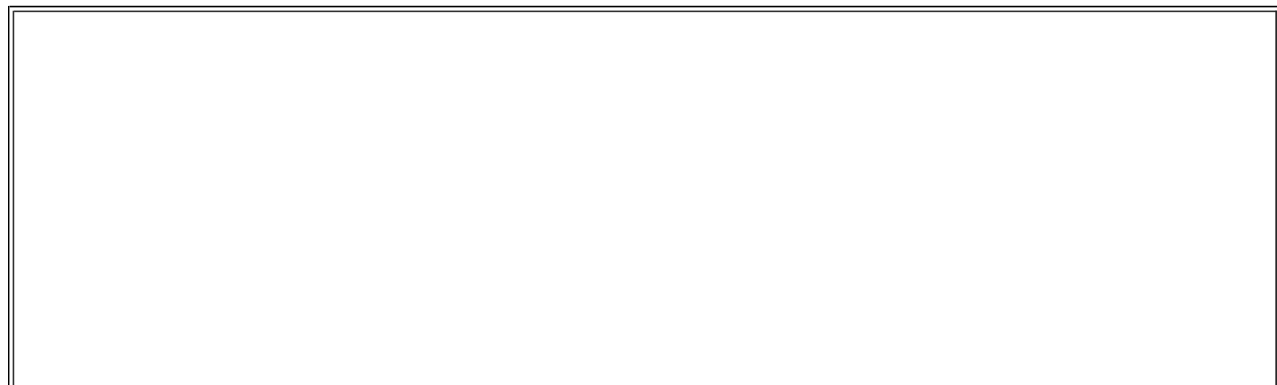

Figure 6: Fluid Supply Line

Item 1: 12-544-01-05 Cleaning Solution Supply Line

Item 2: 12-544-01-10 Injector

21. Install cleaning solution supply line onto injector (Figure 6, Items 1 and 2).



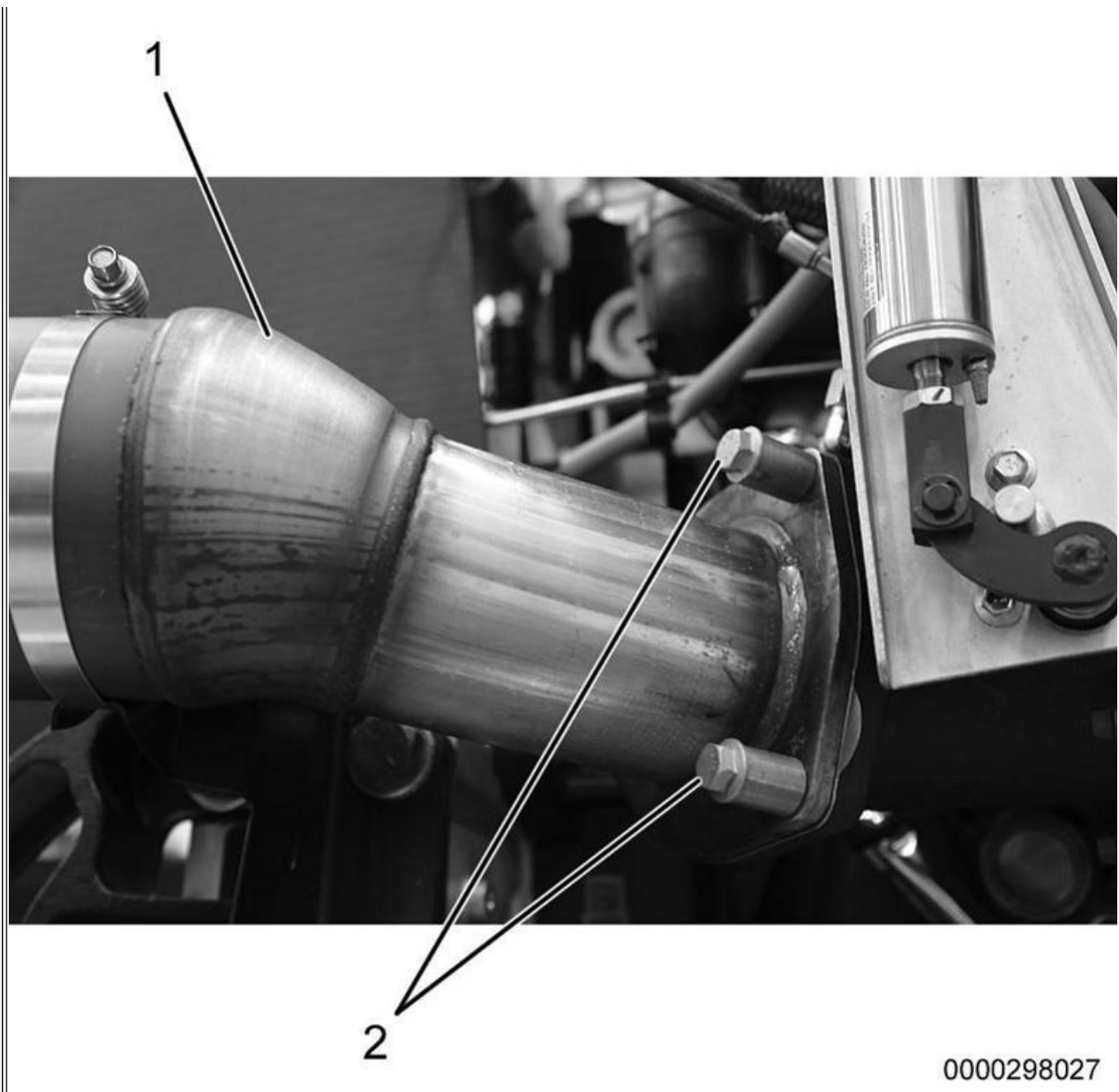

Figure 7: Pre-Diesel Oxidation Catalyst (Pre-DOC) Pipe

Item 1: Pre-DOC pipe

Item 2: Bolt (3) (1 not shown)

22. Remove bolts (Figure 7, Item 2), spacers, and clamp (783 only) from pre-DOC pipe (Figure 7, Item 1). Do not discard.

23. Remove pre-DOC pipe from turbocharger outlet.

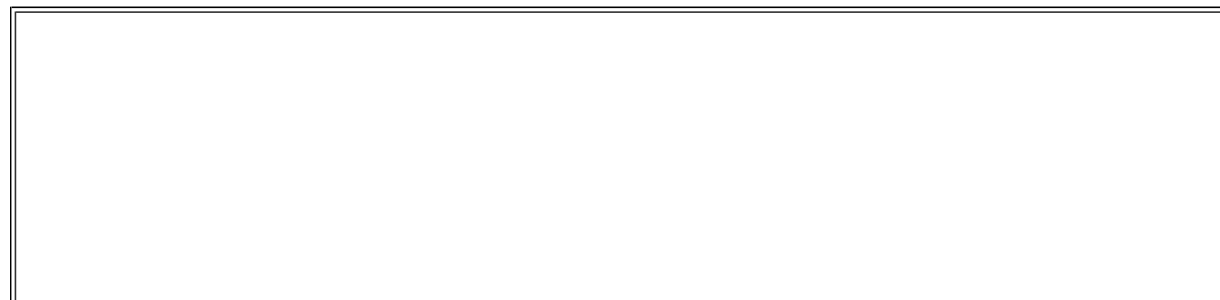

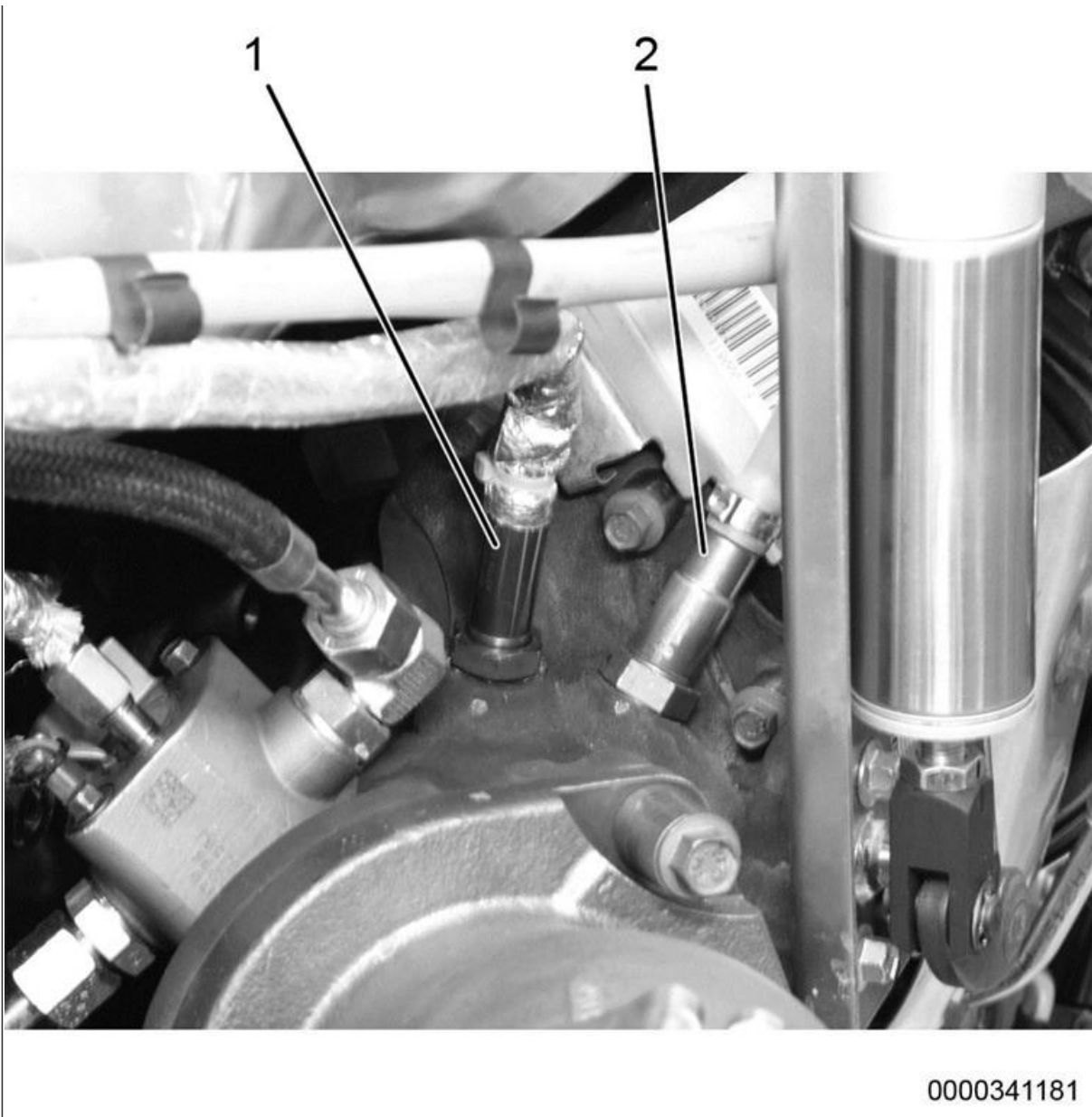

0000341181

Figure 8: NOx and O2 sensors

- Item 1: NOx sensor
- Item 2: O2 sensor

24. Remove NOx and O2 sensors (Figure 8, Items 1 and 2) from pipe.



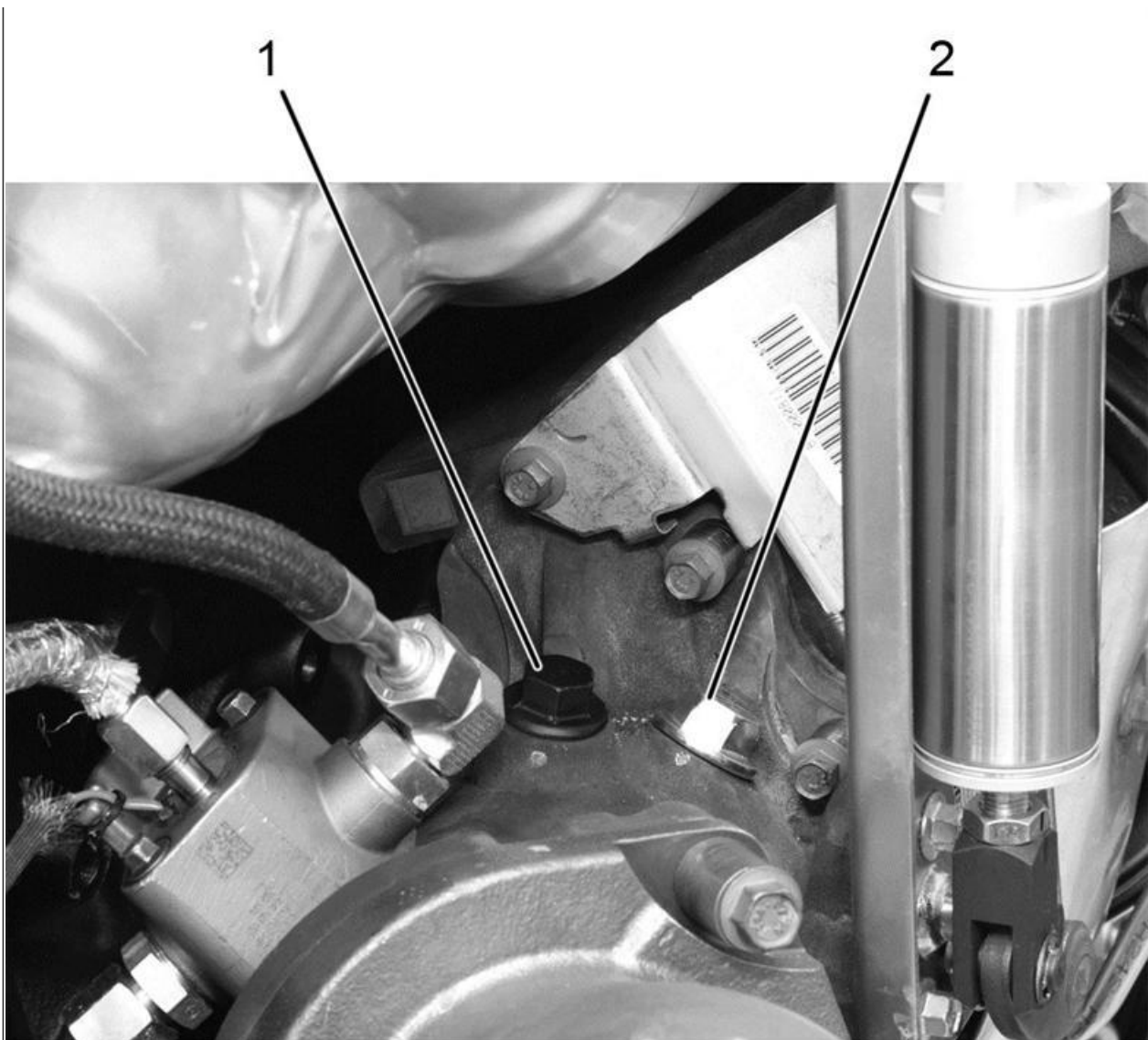

0000341201

Figure 9: NOx and O2 sensor plugs

Item 1: NOx sensor plug (12-544-01-21)

Item 2: O2 sensor plug (12-544-01-20)

25. Install NOx and O2 sensor plugs (Figure 9, Items 1 and 2) into pipe, using a torque wrench, tighten to 27 lb-ft (36 N•m).

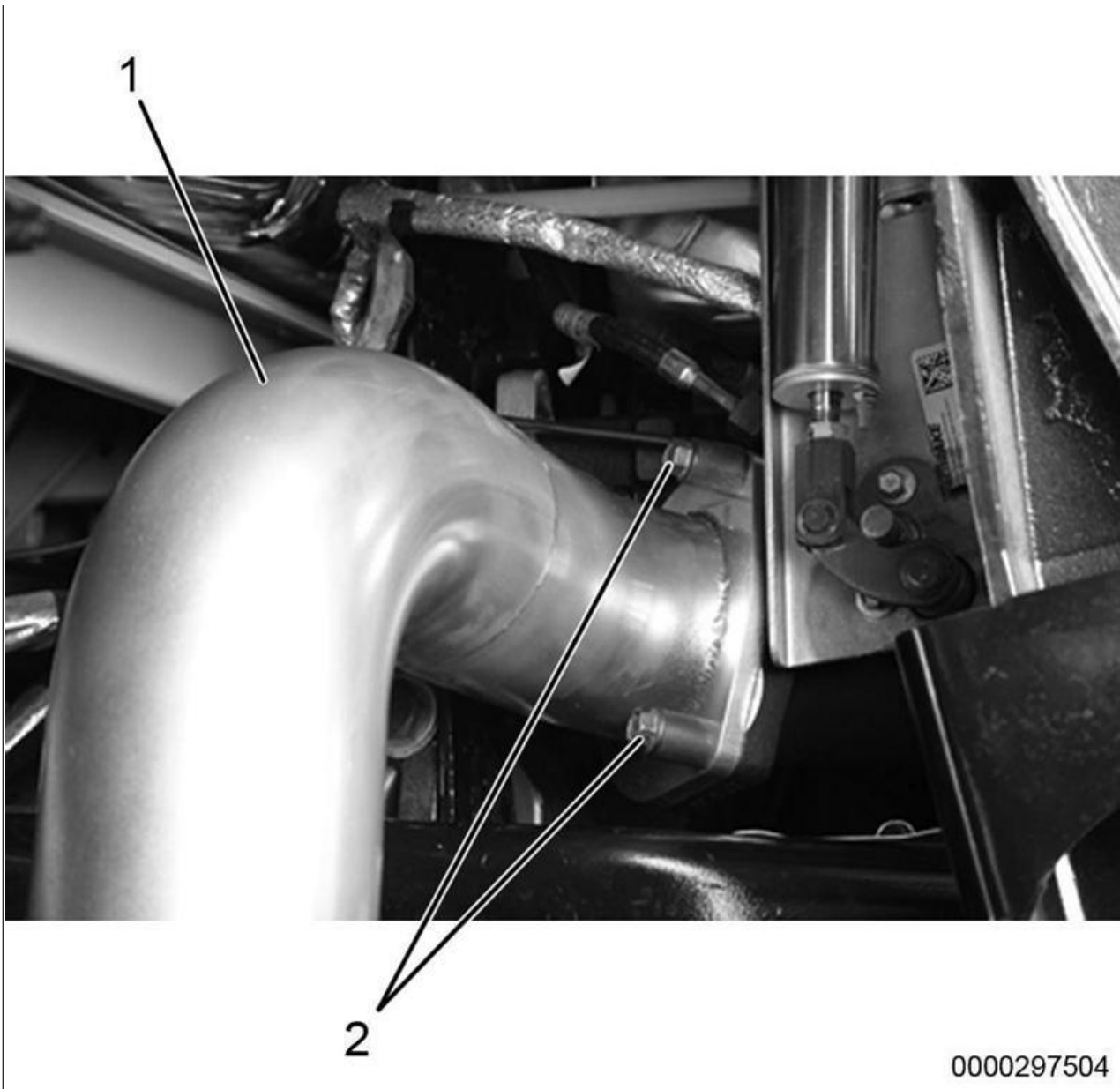

Figure 10: Exhaust Redirect Pipe

Item 1: 12-544-01-16 Exhaust Redirect Pipe

Item 2: Bolt (3) (1 not shown)

26. Using previously removed bolts (Figure 7, Item 2), spacers, and gasket, install exhaust redirect pipe (Figure 10, Item 1). Using torque wrench, tighten bolts to 27 lb-ft (36 N•m).



0000297505

Figure 11: Crankcase Breather Redirect Tube

Item 1: 12-544-01-17 Crankcase Breather Redirect Tube

27. Install crankcase breather redirect tube (Figure 11, Item 1).

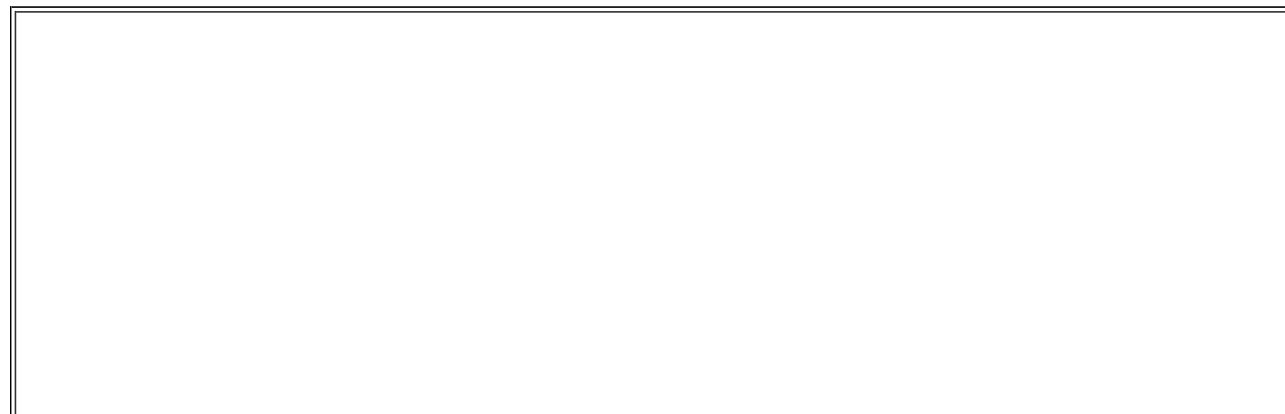

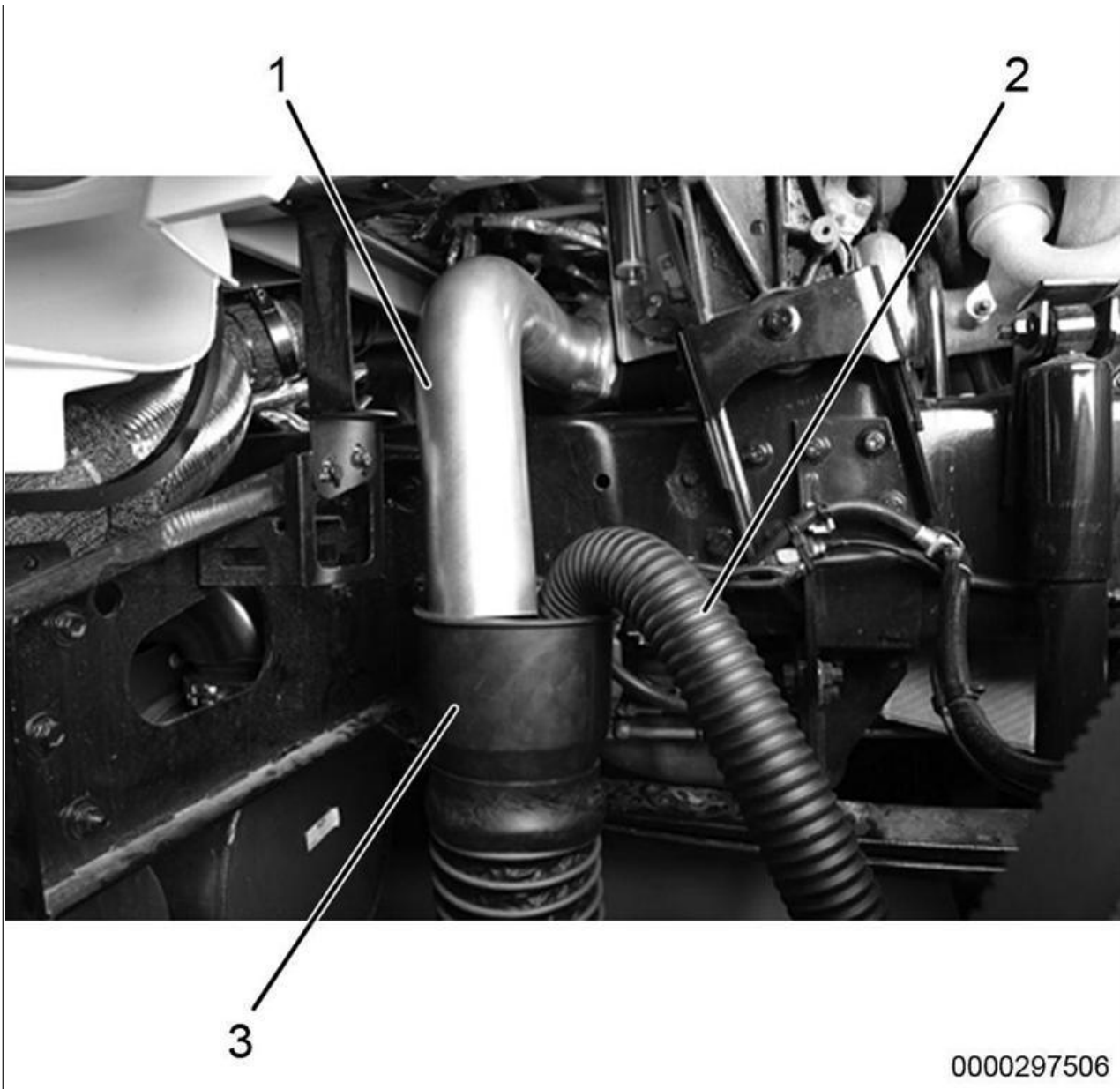

Figure 12: Exhaust Vent

Item 1: 12-544-01-16 Exhaust Redirect Pipe

Item 2: 12-544-01-17 Crankcase Breather Redirect Tube

Item 3: Exhaust vent tube

28. Connect exhaust vent tube (Figure 12, Item 3) to exhaust redirect pipe (Figure 12, Item 1) and crankcase breather redirect tube (Figure 12, Item 2).

29. Install negative battery cable.



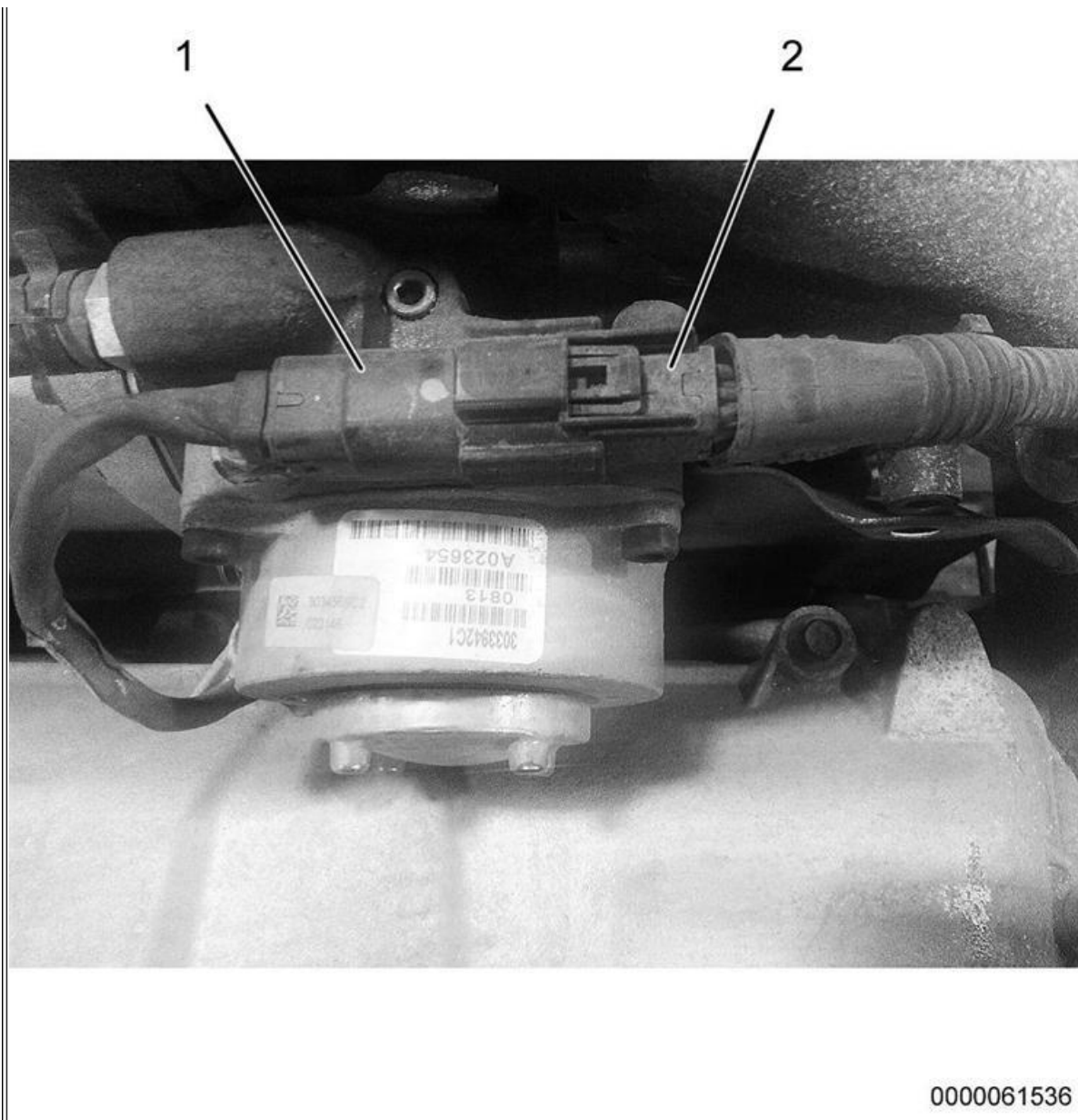
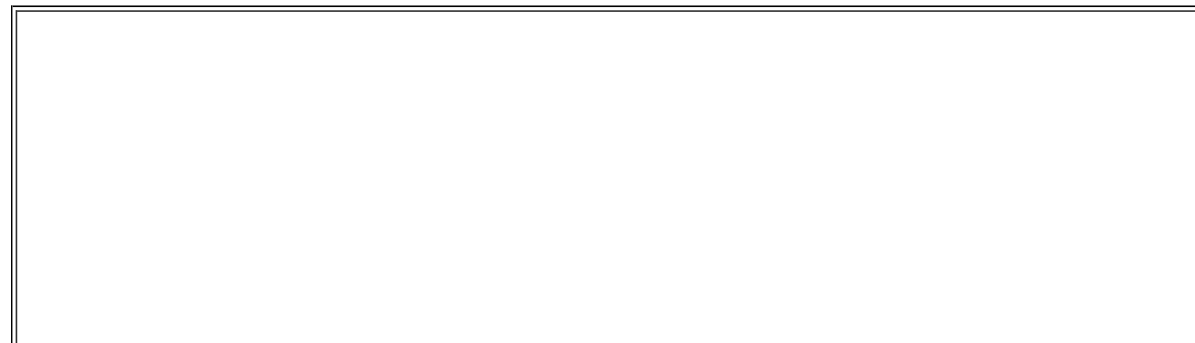

Figure 13: Exhaust Gas Recirculation (EGR) Valve

Item 1: EGR valve connector

Item 2: Connector

30. Disconnect connector (Figure 13, Item 2) from Exhaust Gas Recirculation (EGR) valve connector. Keep connector away from EGR inlet tubes (Figure 13, Item 1).



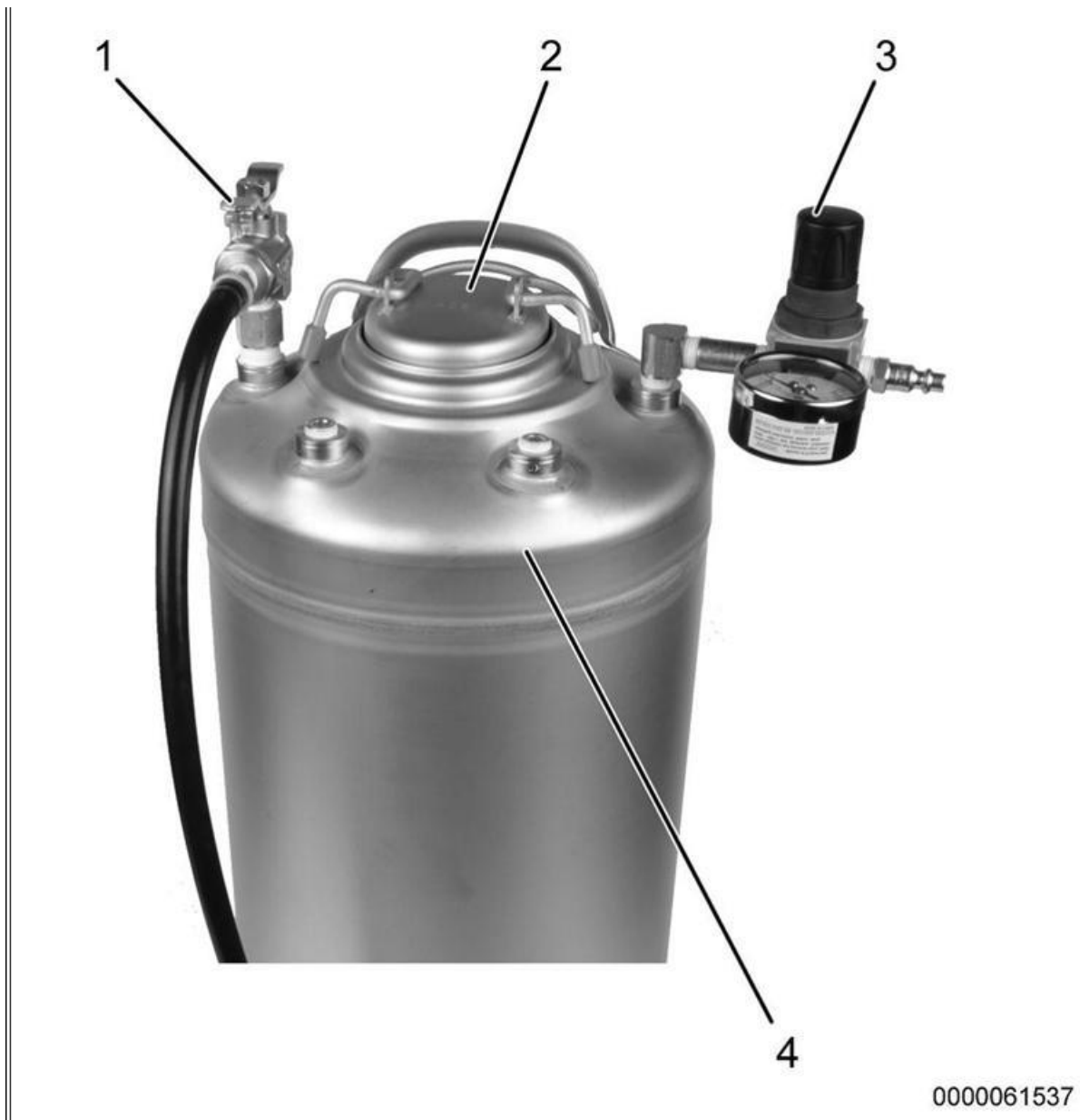

Figure 14: Induction Cleaning System Tank

- Item 1: Shutoff valve
- Item 2: Lid
- Item 3: Pressure regulator
- Item 4: Induction cleaning system tank assembly

31. Open lid on induction cleaning system tank assembly (Figure 14, Item 2). Use a strainer, add 2.5 gal (9.5 L) of EGR cooler cleaner and 2.5 gal (9.5 L) of clean water. Discard the strainer.

32. Verify shutoff valve (Figure 14, Item 1) is closed and pressure regulator is set to 0 psi. Supply air pressure to induction cleaning system tank assembly (Figure 14, Item 4), and set pressure regulator (Figure 14, Item 3) to 75 psi (517 kPa).

33. If ambient temperature is below 32°F (0°C), turn off front and rear A/C.

34. Install cardboard in front of CAC to restrict air flow.

35. Start engine, raise engine speed to 1450 RPM (maximum throttle, or utilizing cruise switches), and wait for engine coolant

temperature to reach 170°F (76.7°C).

36. Log into ServiceMaxx™ and record the Intake Manifold Temperature (IMT).

37. When engine coolant temperature reaches 170°F (76.7°C), open induction cleaning system tank valve (Figure 14, Item 1).

CAUTION: In the event of engine shutdown, immediately shut off induction cleaning system tank valve to prevent intake flooding. Failure to comply may result in property damage.

NOTE: During injection of cleaning solution, IMT will drop, which will indicate induction cleaning system tank assembly solution is entering combustion chamber. Procedure will last approximately 40 - 60 minutes.

38. Intake manifold temperature will rise when cleaning solution is used up, indicating completion of solution dosing into intake. Continue operating engine at 1450 RPM (maximum throttle) for an additional 5 minutes.

39. Close induction cleaning system tank shutoff valve (Figure 14, Item 1).

40. Shut down engine.

41. Remove air pressure from induction cleaning system tank assembly. Allow time for pressure to drop before opening the induction cleaning system tank assembly lid.

42. Open induction cleaning system tank assembly lid and verify level of fluid remaining is minimal. If a substantial amount of fluid is remaining in the tank after the test procedure is performed and IMT has increased to the previously recorded temperature, the injector may need service.

INSTALLATION PROCEDURE

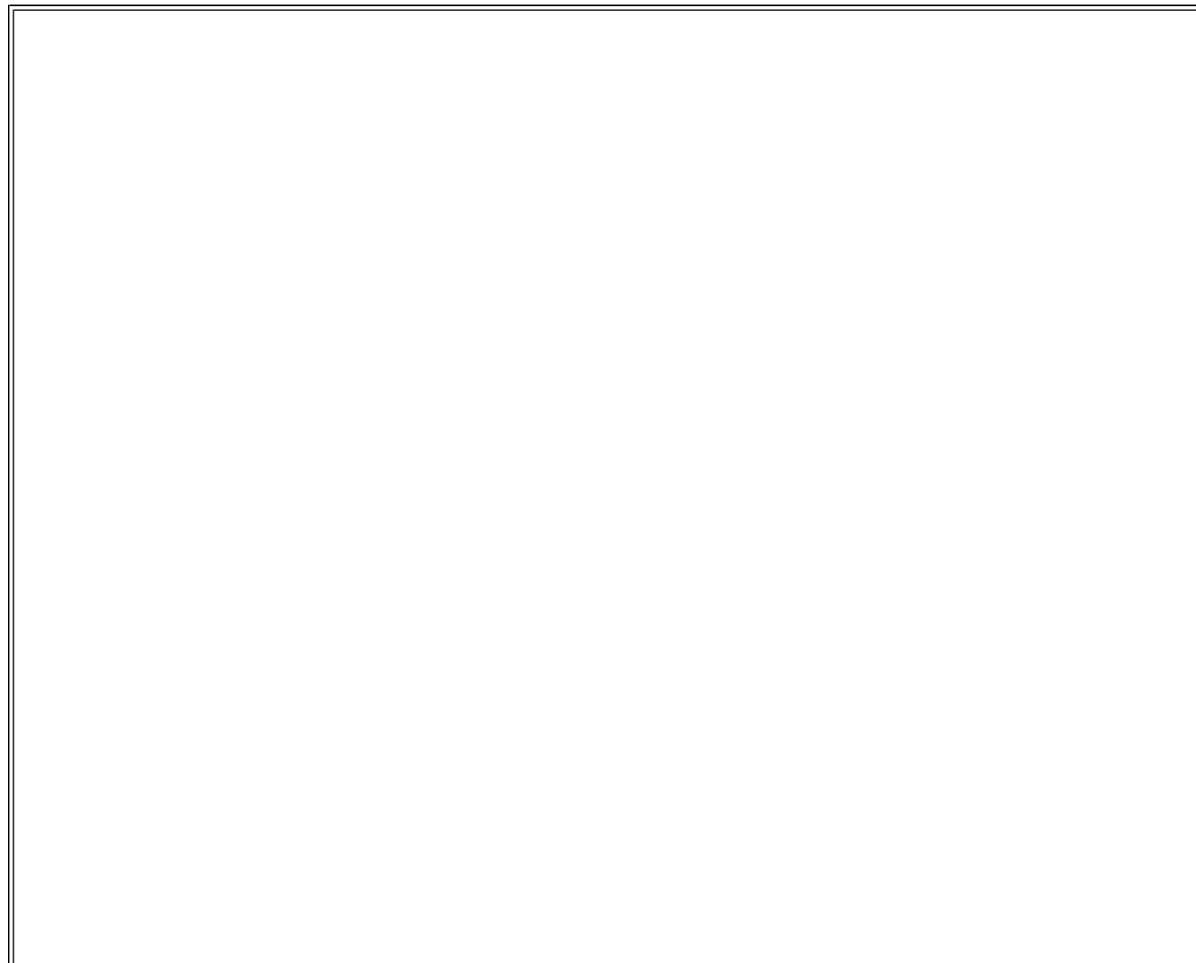

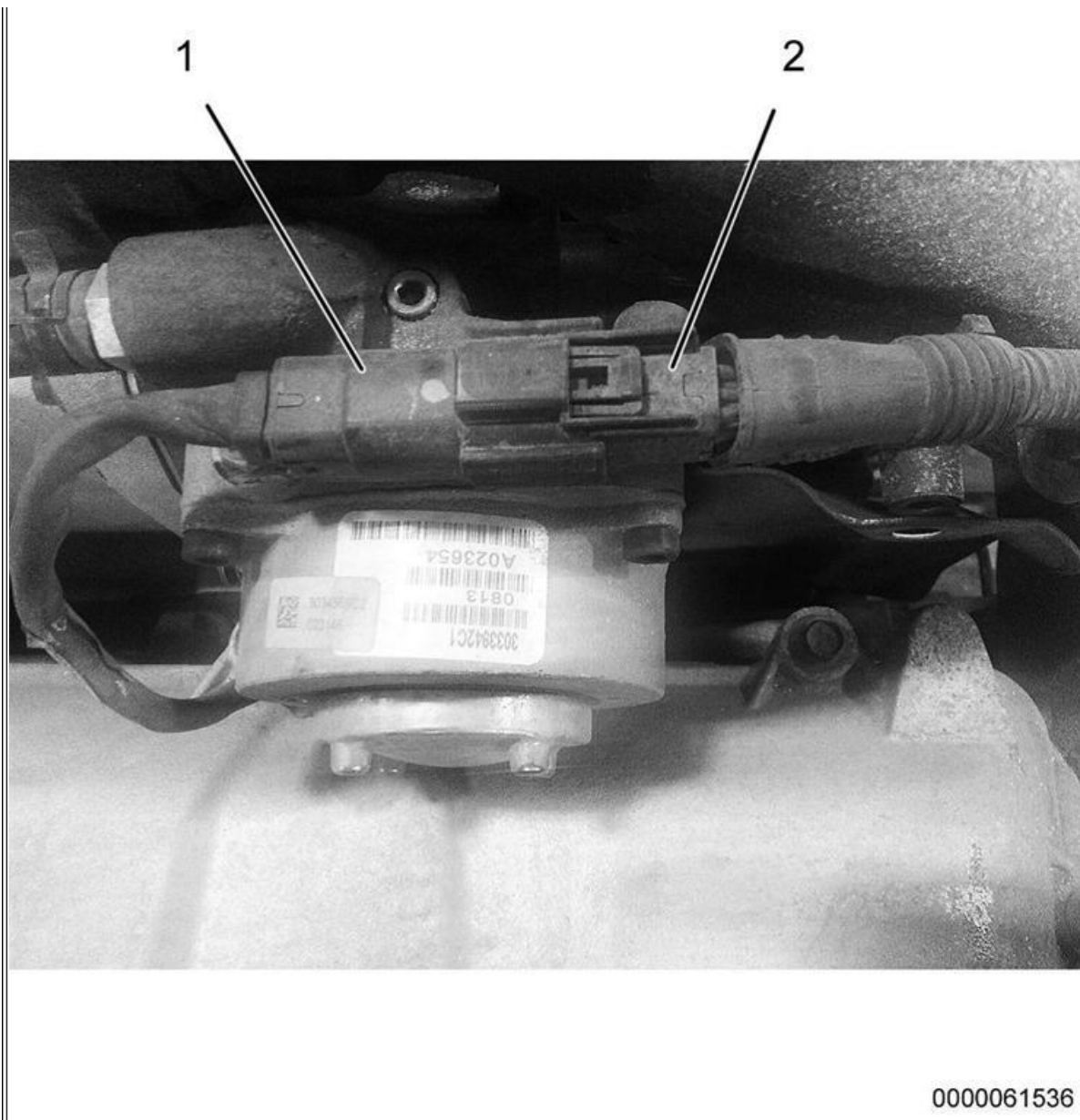

Figure 15: Exhaust Gas Recirculation (EGR) Valve

Item 1: EGR valve connector

Item 2: Connector

43. Connect connector (Figure 15, Item 2) to EGR valve connector (Figure 15, Item 1).

44. Replace engine oil, oil filter, and centrifuge oil filter. Refer to [MaxxForce® 11 and 13 Engine Service Manual \(EPA 10\), 0000001682](#).

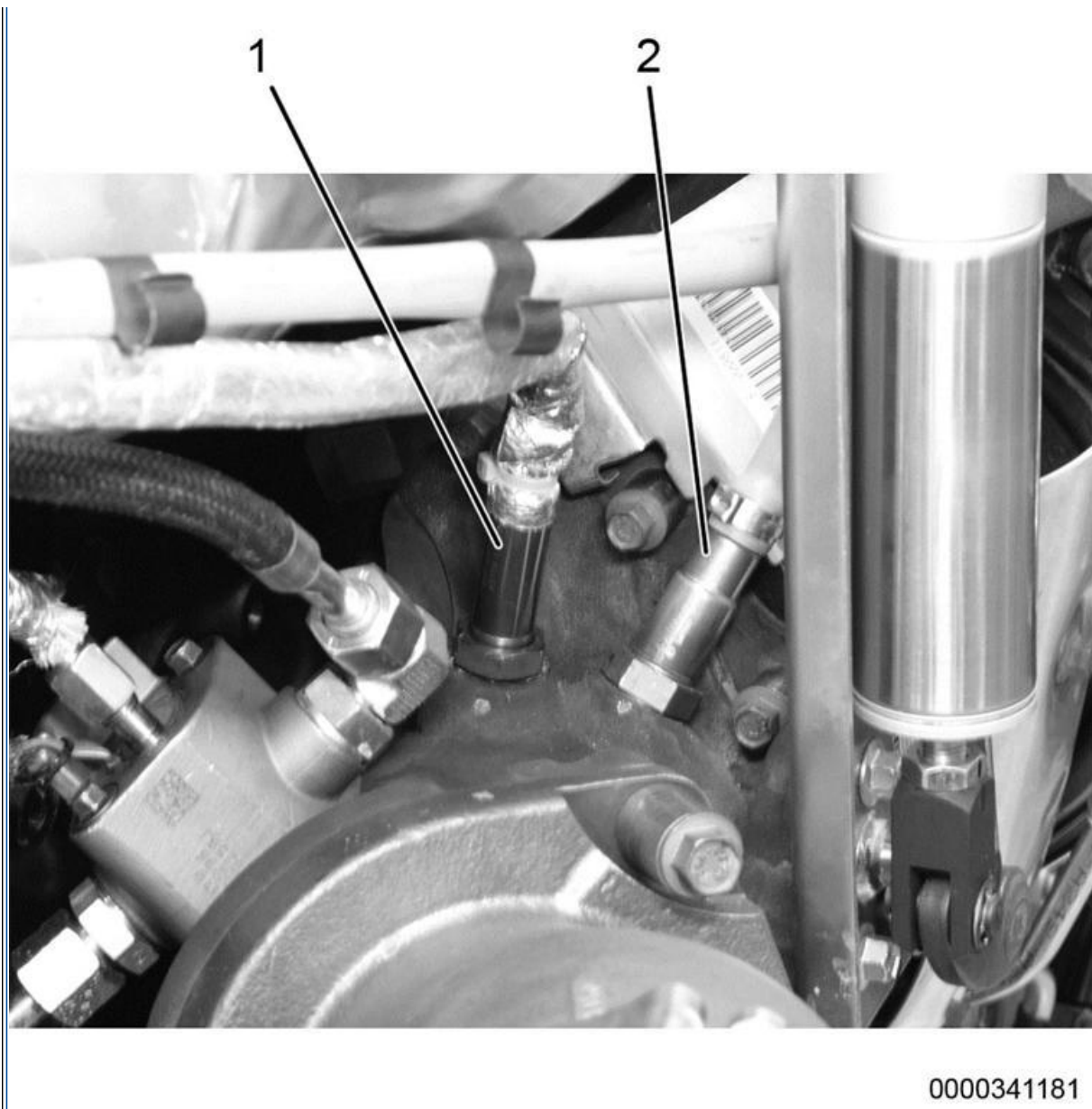

Figure 16: NOx and O2 sensors

[Item 1: NOx sensor](#)

[Item 2: O2 sensor](#)

45. Remove O2 and NOx sensor plugs and reinstall O2 and NOx sensors (Figure 16, items 1 and 2). Refer to [MaxxForce® 11 and 13 Engine Service Manual \(EPA 10\), 0000001682](#).

46. Remove negative battery cable.

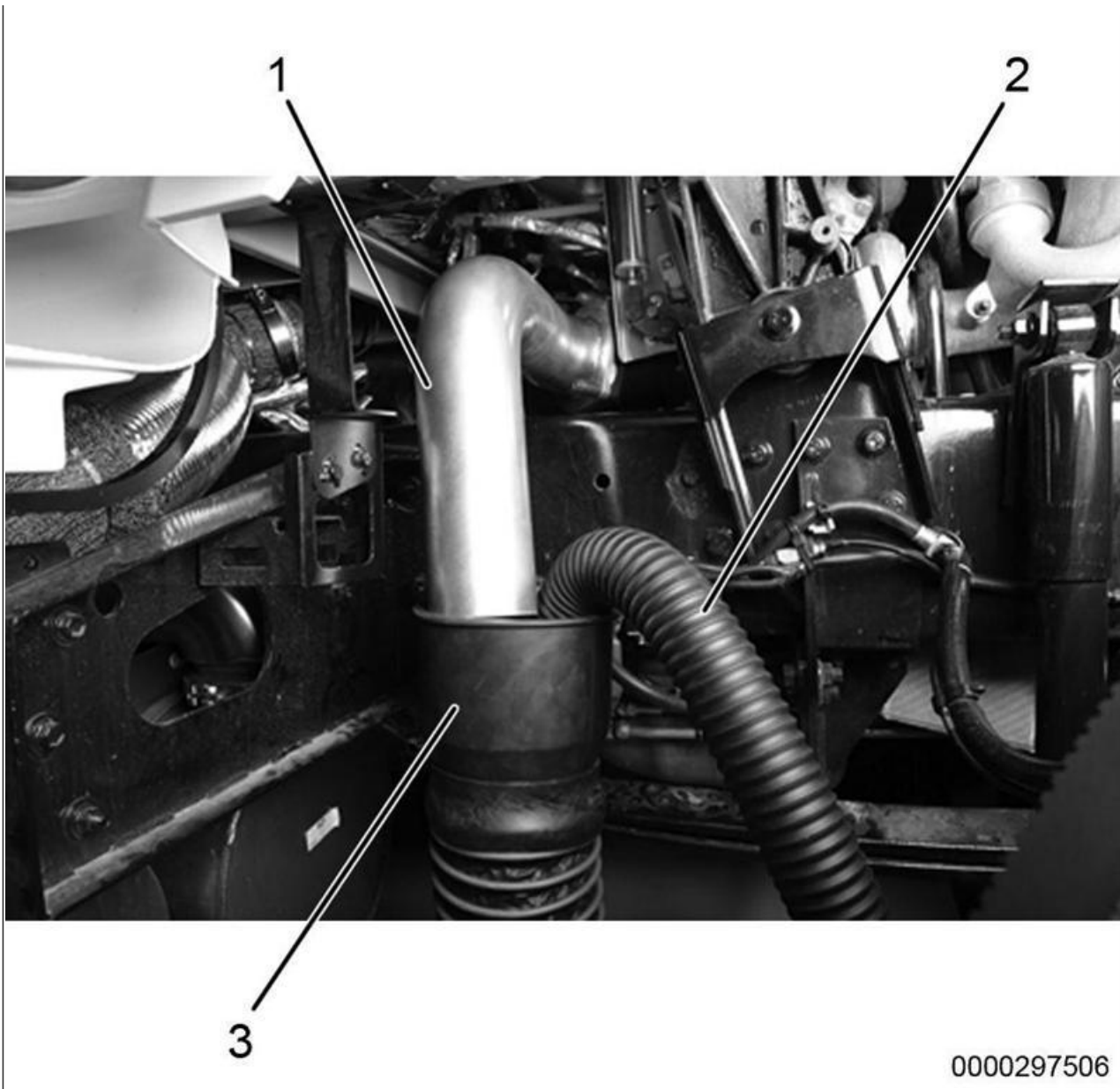

Figure 17: Exhaust Vent

Item 1: 12-544-01-16 Exhaust Redirect Pipe

Item 2: 12-544-01-17 Crankcase Breather Redirect Tube

Item 3: Exhaust vent tube

47. Remove exhaust vent tube (Figure 17, Item 3).

48. Remove crankcase breather redirect tube from vehicle (Figure 17, Item 2).

49. Remove exhaust redirect pipe (Figure 17, Item 1). Do not discard spacers, bolts or gasket.

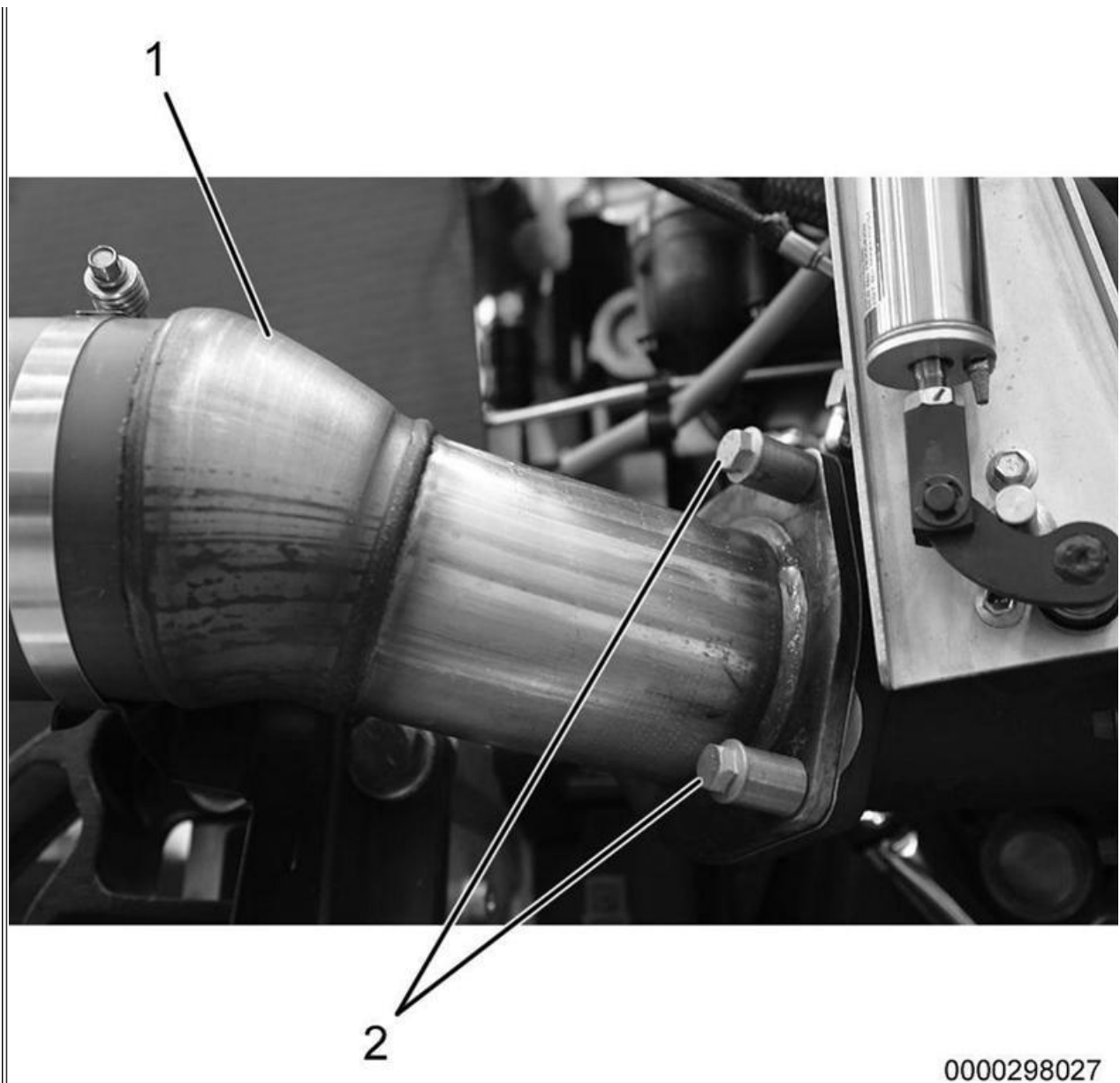

Figure 18: Pre-Diesel Oxidation Catalyst (Pre-DOC) Pipe

Item 1: Pre-DOC pipe

Item 2: Bolt (3) (1 not shown)

50. Position and install pre-DOC pipe (Figure 18, Item 1) onto turbocharger outlet with gaskets, spacers, and bolts. If necessary replace worn or damaged gaskets with new. Using a torque wrench, tighten bolts (Figure 18, Item 2) to 27 lb-ft (36 N•m).

51. Install clamp to pre-DOC pipe (783 only). Using torque wrench, tighten to 62 lb-in (7 N•m).

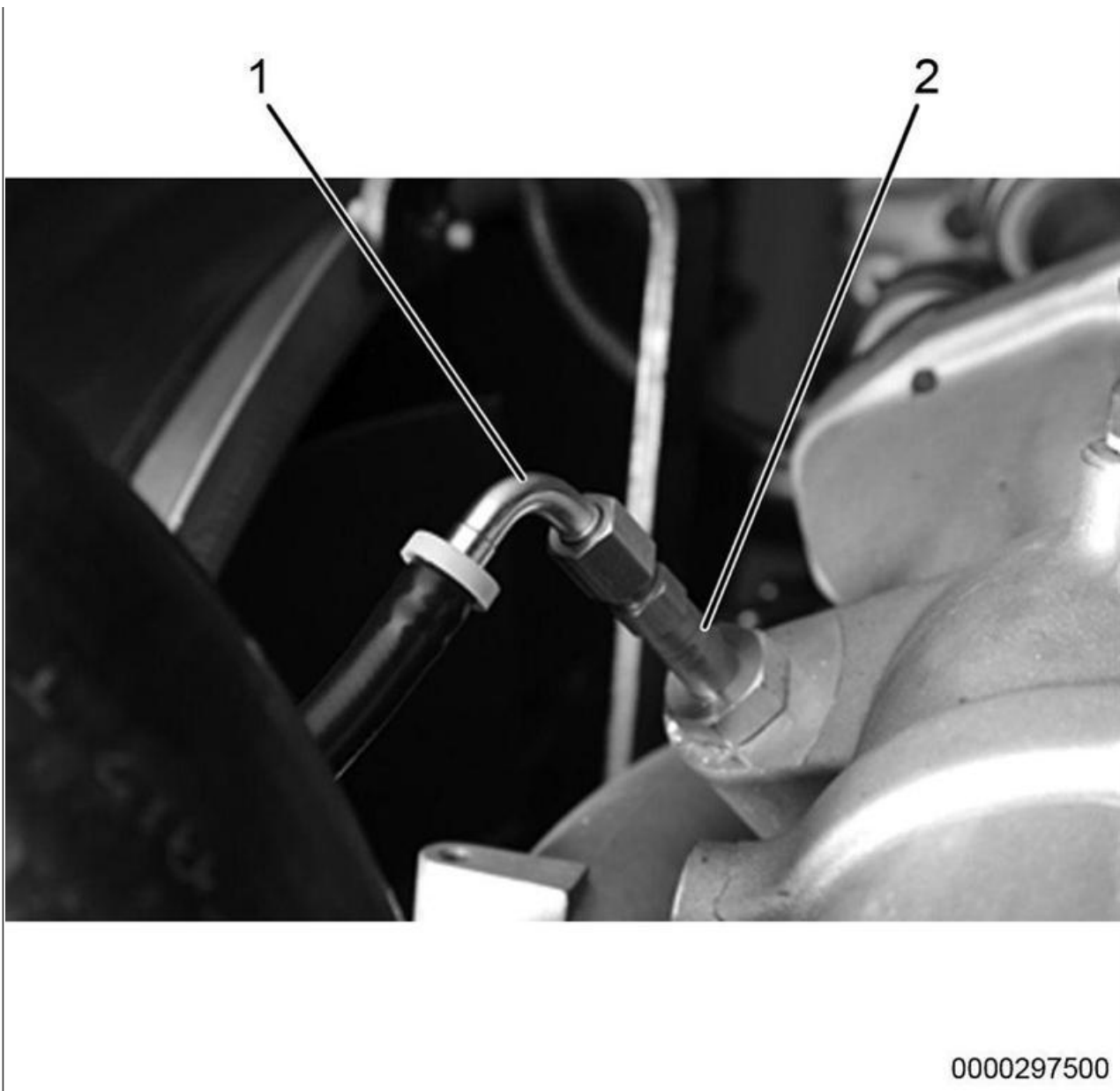

Figure 19: Fluid Supply Line

Item 1: 12-544-01-05 Cleaning Solution Supply Line

Item 2: 12-544-01-10 Injector

52. Remove kit-supplied cleaning solution supply line and injector assembly (Figure 19, Items 1 and 2) from cold start fuel igniter port.

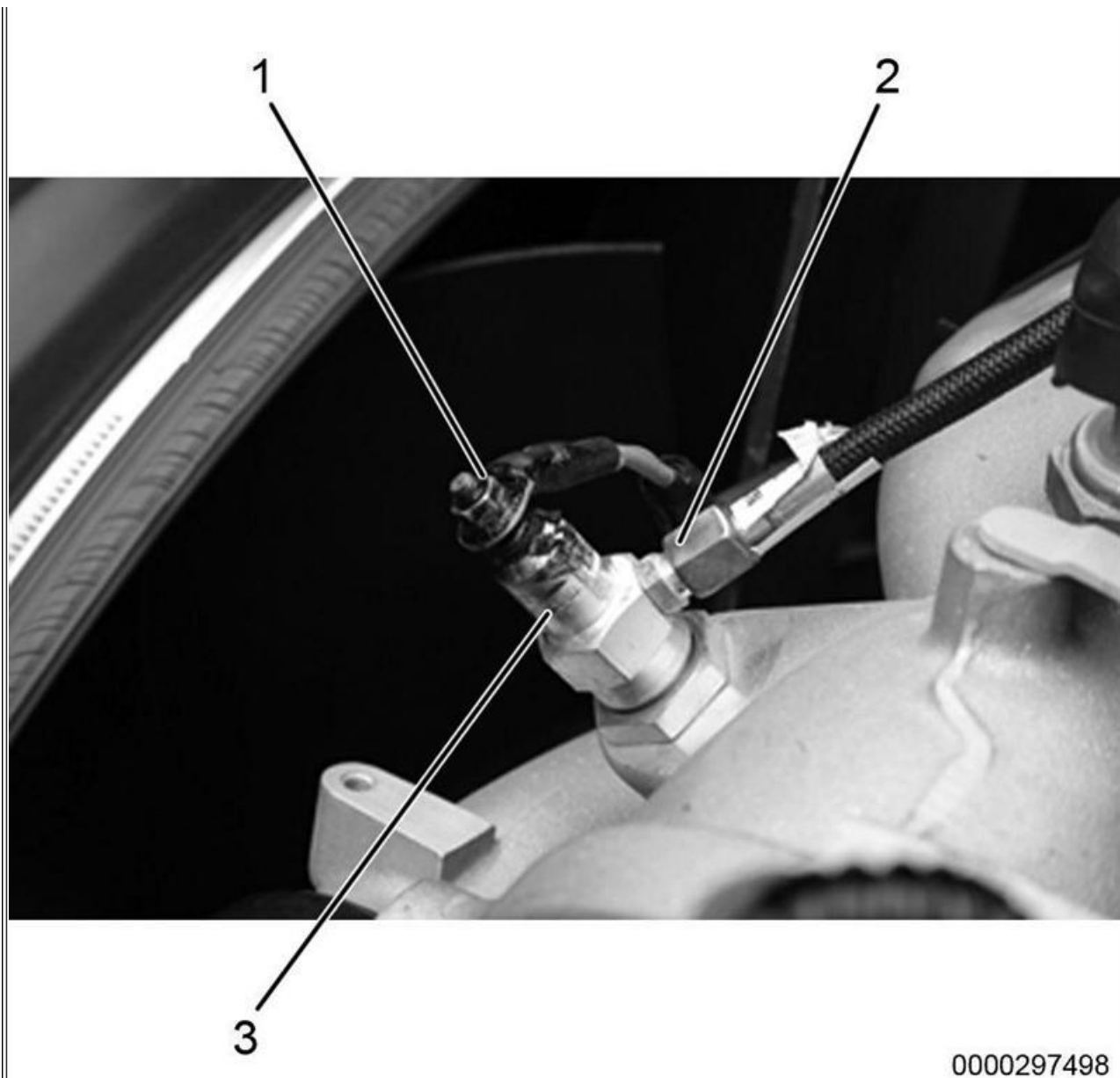

Figure 20: Cold Start Fuel Igniter

Item 1: Cold start electrical connector

Item 2: Cold start fuel supply line

Item 3: Cold start fuel igniter

53. Install cold start fuel igniter (Figure 20, Item 3). Using torque wrench, tighten to 17 lb-ft (23 N•m).
54. Install cold start electrical connector (Figure 20, Item 1). Using torque wrench, tighten to 35 lb-in (4 N•m).
55. Install cold start fuel supply line (Figure 20, Item 2). Using torque wrench, tighten to 132 lb-in (10 N•m).
56. Remove air filter housing.
57. Disengage locks and disconnect connectors from kit-supplied induction cleaning ECM (Figures 2 and 3, Items 1 and 2).

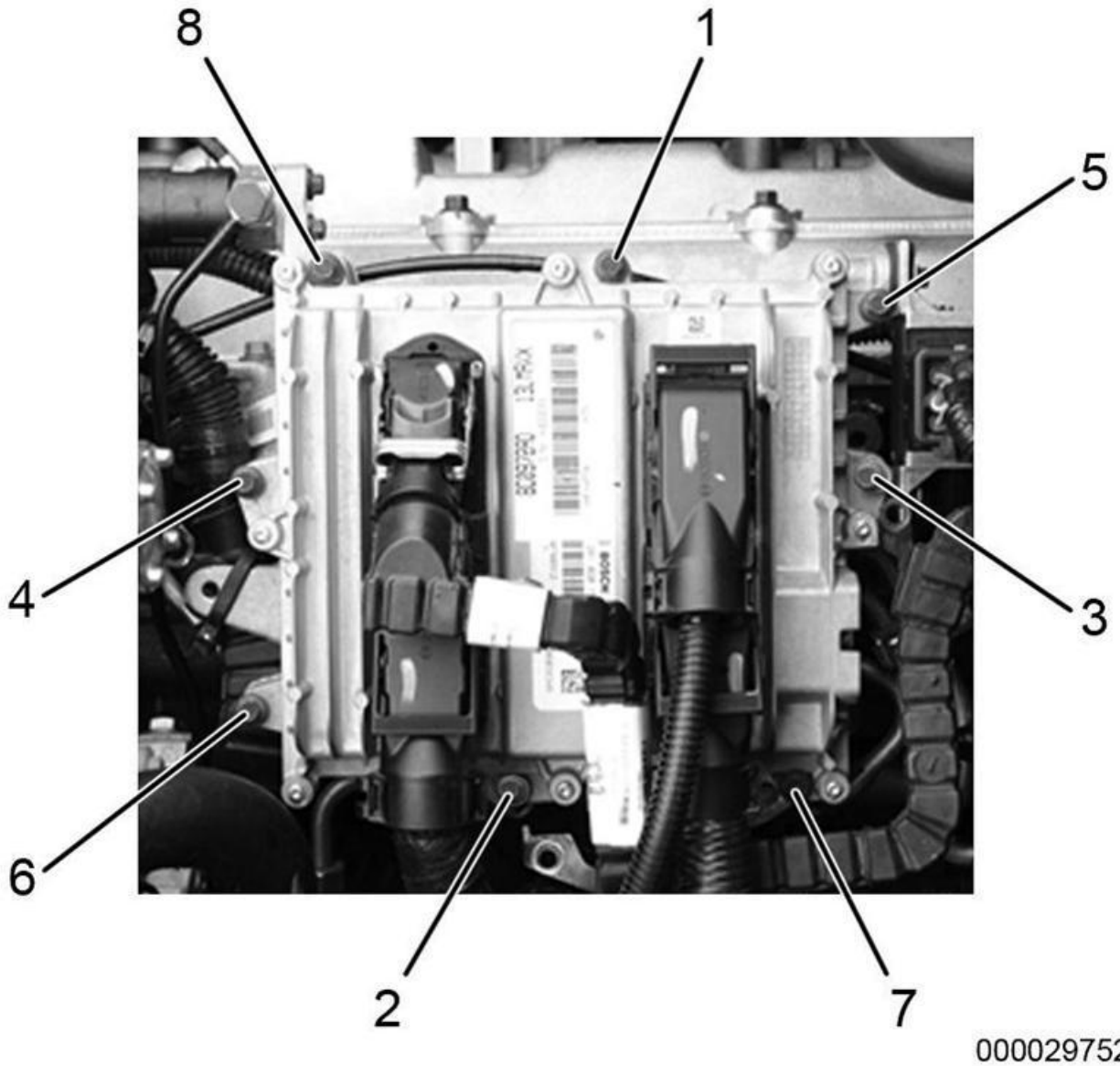

0000297529

Figure 21: ECM Torque Sequence

58. Remove kit-supplied induction cleaning ECM. Do not discard bolts. Install original ECM using eight bolts. Using torque wrench and torque sequence (Figure 21), tighten bolts to 89 lb-in (10 N•m).

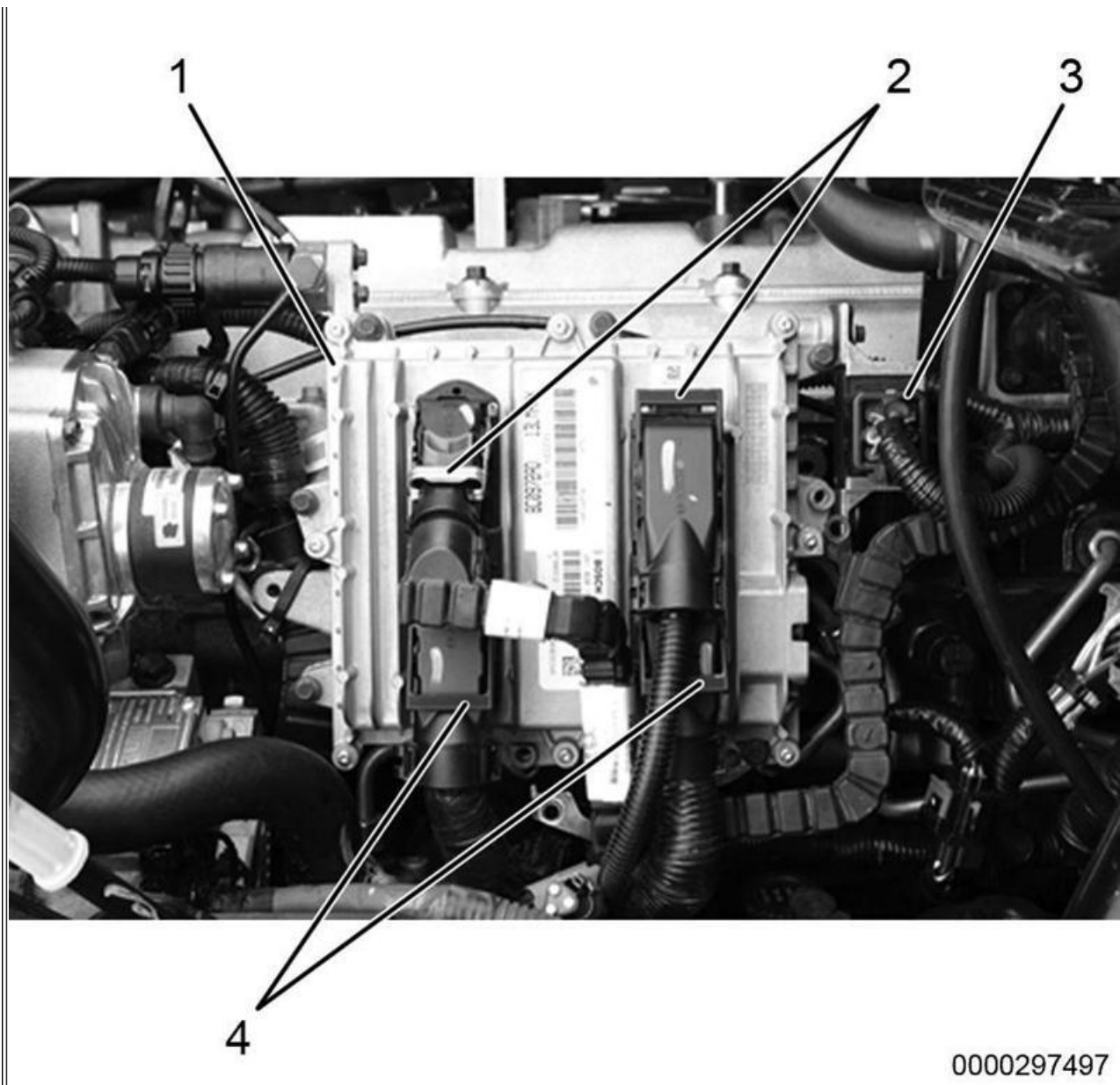

Figure 22: Electronic Control Module (ECM) Connectors

Item 1: ECM

Item 2: Upper ECM connector lock (2)

Item 3: Cold start relay

Item 4: Lower ECM connector lock (2)

59. Connect cold start relay connector (Figure 22, Item 3) next to ECM.

60. Connect ECM connectors and engage locks (Figure 22, Items 2 and 4).

61. Install air filter housing.

62. Install negative battery cable.

63. Close hood.

64. Remove wheel chocks.

65. Rinse tank of all soap residue and refill with at least 1 liter of clean water. Seal and pressurize tank and

spray clean water to flush hose and injector. Continue spraying for at least 30 seconds to 1 minute after water is exhausted to air-dry injector. Failure to perform this cleaning may result in a contaminated hose assembly, a restricted injector and poor overall tool performance.

WARRANTY INFORMATION

Warranty Claim Coding:

Group:	12000 - Engine
Noun:	335 - Gasket, Cylinder Head

Standard Repair Times:

Description	Chassis	Engine	SRT	Hours
Valve Lash (Clearance), Adjust	ProStar	MaxxForce 13/N13	R12-1308U	0.7
Valve Lash (Clearance), Adjust	TranStar	MaxxForce 13/N13	Q12-1308U	0.7
Valve Lash (Clearance), Adjust	WorkStar	MaxxForce 13/N13	N12-1308U	0.7
Valve Lash (Clearance), Adjust	PayStar	MaxxForce 13/N13	T12-1308U	0.7
Cylinder Head Induction Cleaning, Perform	ProStar	MaxxForce 13/N13	R12-1335U-20	3.4
Cylinder Head Induction Cleaning, Perform	TranStar	MaxxForce 13/N13	Q12-1335U-20	3.4
Cylinder Head Induction Cleaning, Perform	WorkStar	MaxxForce 13/N13	N12-1335U-20	3.4
Cylinder Head Induction Cleaning, Perform	PayStar	MaxxForce 13/N13	T12-1335U-20	3.4

[SRT Manual](#)

OTHER RESOURCES

[Master Service Information Site](#)

 Hide Details

Feedback Information

Viewed: 6579

Helpful: 28

Not Helpful: 1

No Feedback Found