

**Description of Revisions:** *This bulletin replaces the version dated August 2008. Information is included about connecting daytime running lights. The vehicle model list has also been revised.*

## General Information

Western Star vehicles are built with DRLs enabled. If the vehicle is ordered with data code 311-998 (NO DAY-TIME RUNNING LIGHTS), the DRLs are disabled during assembly. Refer to installation print 836A1-3432. In most cases, wires were not cut as indicated in the installation print, but removed from the connector cavities to allow for future connection.

NOTE: Daytime Running Lights (DRLs) are required by law in Canada. Daimler Trucks North America recommends keeping DRLs operational in all locations, even where not required by law.

The following instructions can be used to enable or disable DRLs where it is permissible.

IMPORTANT: If disabling the DRLs, do not cut the wires. Fold back and tape the wires to allow for connection in the future.

## Disconnecting or Connecting Daytime Running Lights

### Vehicles without Star Gauge Dash, Built Prior to February 2002

1. Shut down the engine, set the parking brake, and chock the tires.
2. Disconnect the negative leads from the batteries.
3. Remove the four screws that secure the instrument panel, then pull the top of the panel forward to access instrument panel wiring. See [Fig. 1](#).  
On vehicles with fixed steering columns, remove the bolts that hold the steering column to the dash assembly to lower the steering column for access.
4. Disconnect the blue PECV connector from the left-hand side of the Electronic Control Center (ECC). See [Fig. 2](#).
5. Note the cavity location of wire LB08A, then tag the wire with that location so that the daytime running lights can be easily connected, if necessary.
6. If connecting the DRLs, locate wire LB08A; the wire should be folded back and taped off in the harness. Remove the tape and install the wire into its tagged location, then continue with step 8.  
If the location is not tagged and the vehicle uses harness 873b1-3570, install wire LB08A into cavity D1, and continue with step 8.
7. If disconnecting the DRLs, remove wire LB08A from the connector, wrap the terminal end of the wire with electrical tape to prevent unintended connection, then secure the wire back to the harness with a tie-strap. See [Fig. 3](#) for wire removal.
8. Connect the blue PECV connector to the ECC.
9. Disconnect the black PECP connector from the pigtail on the left-hand side of the ECC. See [Fig. 2](#).  
The ECC pigtail to the black PECP connector has colored wires and mates to a headlamp harness connector with white wires.
10. On the white-wire headlamp harness side of the connector, note the cavity location of wire HL08 (B, E, or G), then tag the wire with that location for possible future installation.

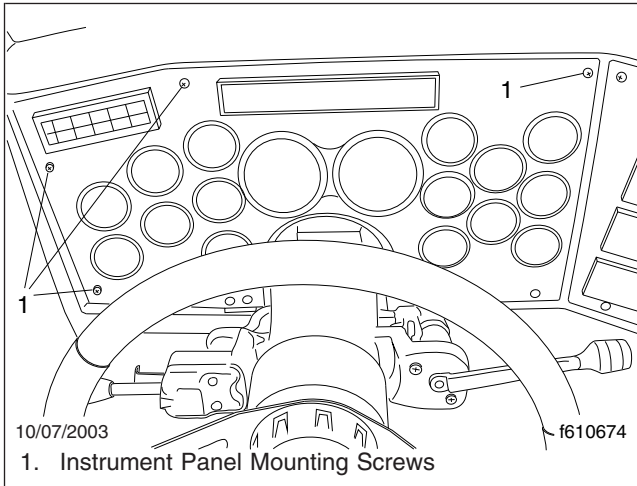

**Fig. 1, Instrument Panel**

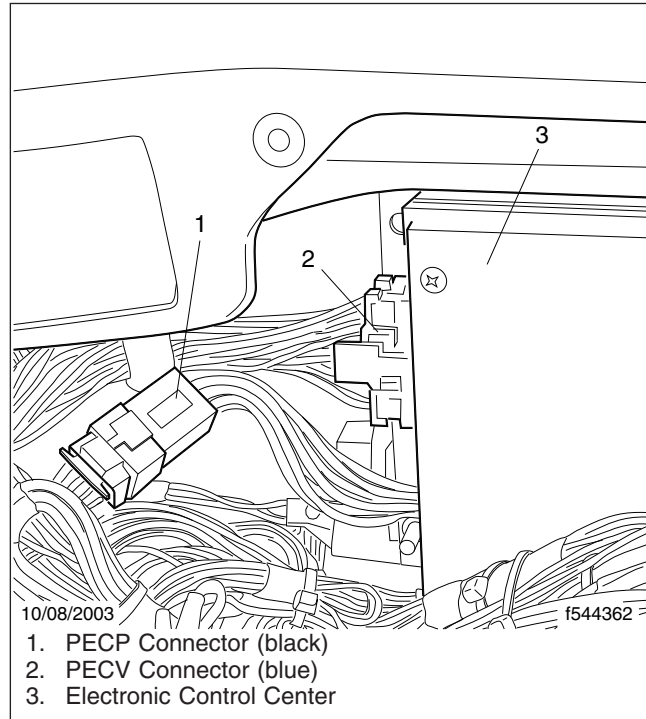

**Fig. 2, Electronic Control Center Connections (for vehicles without Star Gauge dash)**

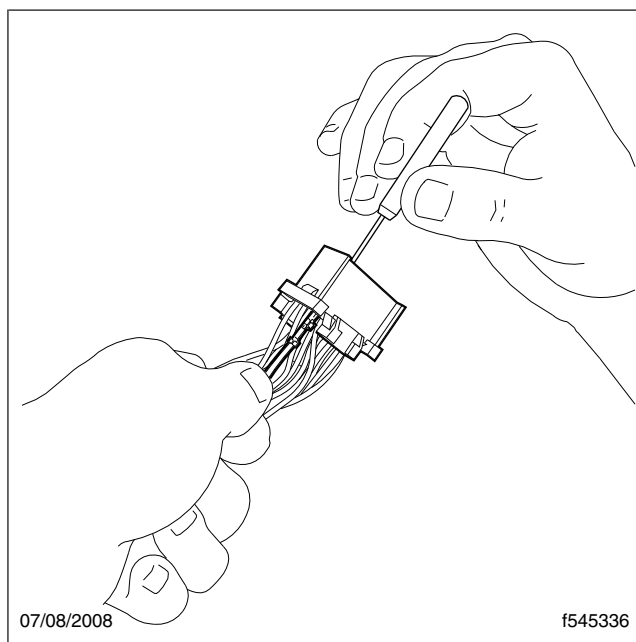

**Fig. 3, Removing the Terminal from the Connector**

11. If connecting the DRLs, locate wire HL08 (B, E, or G); the wire should be folded back and taped off in the harness. Remove the tape and install it into its tagged location. Continue with step 13.  
  
If the location is not tagged, and the vehicle uses harness 873b1-3570, install wire HL08 (B, E, or G) into cavity C. Continue with step 13.
12. If disconnecting the DRLs, remove the wire from the connector, wrap the terminal of the wire with electrical tape to prevent unintended connection, then secure the wire back to the harness with a tie-strap. See **Fig. 3** for wire removal.
13. Connect the PECP connectors.
14. Position the instrument panel and install the screws. If the steering column was lowered, position it into place, and tighten the steering column capscrews 17 lbf-ft (23 N-m).
15. Connect the batteries.
16. Verify correct operation of the lights.

## Vehicles with Star Gauge Dash, Built Since February 2002

1. Shut down the engine, set the parking brake, and chock the tires.
2. Disconnect the negative leads from the batteries.
3. Remove the four screws that secure the instrument panel, then pull the top of the panel forward to access instrument panel wiring. See **Fig. 1**.  
  
On vehicles with fixed steering columns, remove the bolts that hold the steering column to the dash assembly to lower the steering column for access.
4. Disconnect the light gray PECV connector from the left-hand side of the Electronic Control Center (ECC).
5. Find wire LB08A in cavity A10, then tag the wire with that location for possible future installation.
6. If connecting the DRLs, locate wire LB08A; the wire should be folded back and taped off in the harness. Remove the tape and install wire LB08A into cavity A10. Continue with step 8.
7. If disconnecting the DRL, remove the wire from the connector, wrap the terminal end of the wire with electrical tape to prevent unintended connection, then secure the wire back to the harness with a tie-strap. See **Fig. 3** for wire removal.
8. Connect the PECV connector to the left-hand side of the ECC.
9. Disconnect the dark gray PECP connector from the left-hand side of the ECC.
10. Find wire HL08H (this wire may be HL05B in later models) in cavity G, then tag the wire with that location for future installation, if desired.
11. If connecting DRLs, locate wire HL05H (this wire may be HL05B in later models); the wire should be folded back and taped off in the harness. Remove the tape and install wire HL05H or HL05B into cavity G. Continue with step 13.
12. If disconnecting the DRLs, remove the wire from the connector, wrap the terminal of the wire with electrical tape to prevent unintended connection, then secure the wire back to the harness with a tie-strap. See **Fig. 3** for wire removal.
13. Connect the PECP connector to the left-hand side of the ECC.
14. Position the instrument panel and install the screws. If the steering column was lowered, position it into place, and tighten the steering column capscrews 17 lbf-ft (23 N-m).
15. Connect the batteries.

16. Verify correct operation of the lights.

### **Warranty**

This bulletin is informational only; warranty does not apply.