

January 2015

FL675A-C

NHTSA # 14V-760 (School Bus)

NHTSA # 14V-759 (Non-School Bus)

Transport Canada 14-549 (School Bus)

Subject: TBB Minotour Fuel Tank Straps

Models Affected: Specific Thomas Built Buses Minotour GM/Chevrolet and Ford chassis buses manufactured April 2, 2012, through October 3, 2014.

General Information

Daimler Trucks North America LLC (DTNA), on behalf of its wholly owned subsidiary, Thomas Built Buses (TBB), has decided that a defect that relates to motor vehicle safety exists on the vehicles mentioned above.

There are approximately 5,346 vehicles involved in this campaign.

On certain Minotour buses, the fasteners used to secure the fuel tank straps may have been loosened during the bus assembly process. An unsecured fuel tank strap could potentially allow the fuel tank to contact the ground and possibly leak gasoline. A gasoline leak in proximity to an ignition source may increase the risk of a fire.

The fuel tank strap bolts will be replaced.

Additional Repairs

Dealers must complete all outstanding Recall and Field Service campaigns prior to the sale or delivery of a vehicle. A Dealer will be liable for any progressive damage that results from its failure to complete campaigns before sale or delivery of a vehicle.

Owners may be liable for any progressive damage that results from failure to complete campaigns within a reasonable time after receiving notification.

Work Instructions

Please refer to the attached work instructions.

Replacement Parts

Replacement parts are now available and can be obtained by ordering from your facing Parts Distribution Center.

If our records show your dealership has ordered any vehicles involved in campaign number FL675, a list of the customers and vehicle identification numbers will be available on AccessFreightliner.com. Please refer to this list when ordering parts for this recall.

Recall Campaign

January 2015

FL675A-C

NHTSA # 14V-760 (School Bus)

NHTSA # 14V-759 (Non-School Bus)

Transport Canada 14-549 (School Bus)

IMPORTANT: Parts must be purchased from a GM or Ford dealer as appropriate.

Table 1 – Replacement Parts for FL675A-C

Campaign Number	Part Number	Description	Qty.
FL675A and C (GM Chassis)	11610209	Bolt For Fuel Tank Strap	2 ea
FL657B (Ford Chassis)	N803892-S439	Bolt For Fuel Tank Bracket	2 ea
	N802073-S441	Nut For Fuel Tank Bracket	2 ea

Table 1

Removed Parts

Please follow Warranty Failed Parts Tracking shipping instructions for the disposition of all removed parts.

Labor Allowance

Table 2 – Labor Allowance

Campaign Number	Procedure	Time Allowed (Hours)	SRT Code	Corrective Action
FL675A – School Buses (5,259 units)	Replace fuel tank strap or bracket bolts	0.8	174-6350D	12 – Repair Recall/Campaign
FL675B – School Buses (62 units)				
FL675C – Non-School Buses (25 units)				

Table 2

Claims for Credit

You will be reimbursed for your parts, labor, and handling by submitting your claim through the Warranty system within 30 days of completing this campaign. Please reference the following information in OWL:

- Claim Type is **Recall Campaign**.
- In the Campaign field, enter the campaign number and appropriate group (**FL675-A, FL675-B, or FL657-C**).
- In the Primary Failed Part field, enter **TBB 170727**.
- In the Parts section, enter the appropriate part number(s) as shown in the Replacement Parts Table.
- In the Labor section, enter the appropriate SRT from the Labor Allowance Table. Administrative time will be included automatically as SRT 939-6010A for 0.3 hours.
- The VMRS Component Code is **044-001-053** and the Cause Code is **A1 - Campaign**.

Recall Campaign

Daimler Trucks
North America LLC

January 2015

FL675A-C

NHTSA # 14V-760 (School Bus)

NHTSA # 14V-759 (Non-School Bus)

Transport Canada 14-549 (School Bus)

- **U.S. and Canada – Reimbursement for Prior Repairs.** When a customer asks about reimbursement, please do the following:
 - Accept the documentation of the previous repair.
 - Make a brief check of the customer's paperwork to see if the repair may be eligible for reimbursement.
 - Submit a Recall Pre-Approval request for a decision and authorized amount.
 - Submit a "based on" claim for the approved pre-approval.
 - Attach the documentation to the pre-approval request.
 - When your claim is paid, reimburse the customer the appropriate amount.

IMPORTANT: OWL must be viewed prior to performing the recall to ensure the vehicle is involved and the campaign has not been previously completed. Also, check for a completion sticker prior to beginning work.

Contact the Warranty Campaigns Department at (336) 889-4871, from 8:00 a.m. to 5:00 p.m. Eastern Time, Monday through Friday, via Web inquiry at AccessFreightliner.com / My Tickets and Submit an Inquiry, if you have any questions or need additional information.

To return excess kit inventory related to this campaign, U.S. dealers must submit a Parts Authorization Return (PAR) to the Memphis PDC. Canadian dealers must submit a PAR to their facing PDC. All kits must be in resalable condition. PAR requests must include the original purchase invoice number.

The letter notifying U.S. and Canadian vehicle owners is included for your reference.

Please note that the National Traffic and Motor Vehicle Safety Act, as amended (Title 49, United States Code, Chapter 301), requires the owner's vehicle(s) be corrected within a reasonable time after parts are available to you. The Act states that failure to repair a vehicle within 60 days after tender for repair shall be prima facie evidence of an unreasonable time. However, circumstances of a particular situation may reduce the 60 day period. Failure to repair a vehicle within a reasonable time can result in either the obligation to (a) replace the vehicle with an identical or reasonably equivalent vehicle, without charge, or (b) refund the purchase price in full, less a reasonable allowance for depreciation. The Act further prohibits dealers from selling a vehicle unless all outstanding recalls are performed. Any lessor is required to send a copy of the recall notification to the lessee within 10 days. Any subsequent stage manufacturer is required to forward this notice to its distributors and retail outlets within five working days.

January 2015

FL675A-C

NHTSA # 14V-760 (School Bus)

NHTSA # 14V-759 (Non-School Bus)

Transport Canada 14-549 (School Bus)

Copy of Notice to Owners

Subject: TBB Minotour Fuel Tank Straps

This notice is sent to you in accordance with the requirements of the National Traffic and Motor Vehicle Safety Act. This notice is sent to you in accordance with the Canadian Motor Vehicle Safety Act.

Daimler Trucks North America LLC, on behalf of its wholly owned subsidiary, Thomas Built Buses, has decided that a defect which relates to motor vehicle safety exists on specific Thomas Built Buses Minotour GM/Chevrolet and Ford chassis buses manufactured April 2, 2012, through October 3, 2014.

On certain Minotour buses, the fasteners used to secure the fuel tank straps may have been loosened during the bus assembly process. An unsecured fuel tank strap could potentially allow the fuel tank to contact the ground and possibly leak gasoline. A gasoline leak in proximity to an ignition source may increase the risk of a fire.

The fuel tank strap bolts will be replaced.

To arrange for repairs, you should contact your local Thomas Built Buses dealer immediately. Thomas will remedy this defect without charge. The repair should take approximately an hour depending on your vehicle, and will be performed at no charge to you.

You may be liable for any progressive damage that results from your failure to complete the Recall within a reasonable time after receiving notification.

If you do not own the vehicle that corresponds to the identification number(s) which appears on the Recall Notification, please return the notification to the Warranty Department with any information you can furnish that will assist us in locating the present owner. If you have leased this vehicle, Federal law requires that you forward this notice to the lessee within 10 days.

If you have paid to have this recall condition corrected prior to this notice, you may be eligible to receive reimbursement. For further information, please contact the Warranty Department at (336) 889-4871, 8 a.m. to 5 p.m. Eastern Time Monday through Friday. To find a dealer in your area please go to www.thomasbus.com.

If you have any questions about this recall, please contact the Warranty Department at (336) 889-4871, 8:00 a.m. to 5:00 p.m. Eastern Time, Monday through Friday. If you are not able to have the defect remedied without charge and within a reasonable time, you may wish to submit a complaint to the Administrator, National Highway Traffic Safety Administration, 1200 New Jersey Avenue, SE., Washington, DC 20590; or call the Vehicle Safety Hotline at (888) 327-4236 (TTY: 800-424-9153); or to <http://www.safercar.gov>. In Canada, you may contact Transport Canada-road safety, 80 rue Noel, Gatineau, Quebec J8Z 0A1 or call 1-800-333-0510.

We regret any inconvenience this action may cause but feel certain you understand our interest in motor vehicle safety.

THOMAS BUILT BUSES WARRANTY DEPARTMENT

Enclosure

January 2015

FL675A-C

NHTSA # 14V-760 (School Bus)

NHTSA # 14V-759 (Non-School Bus)

Transport Canada 14-549 (School Bus)

Work Instructions

Subject: TBB Minotour Fuel Tank Straps

**Models Affected: Specific Thomas Built Buses Minotour
GM/Chevrolet and Ford chassis buses manufactured
April 2, 2012, through October 3, 2014.**

IMPORTANT: Read entire procedure before beginning.



- Do not smoke, carry lighted tobacco, or have an open flame of any type when working or near any fuel-related component. Highly flammable mixtures are always present and may be ignited. Failure to follow these instructions may result in serious personal injury.
- Do not carry personal electronic devices such as cell phones, pagers or audio equipment of any type when working on or near any fuel-related component. Highly flammable mixtures are always present and may be ignited. Failure to follow these instructions may result in serious personal injury.
- When handling fuel, always observe fuel handling precautions and be prepared in the event of fuel spillage. Spilled fuel may be ignited by hot vehicle components or other ignition sources. Failure to follow these instructions may result in serious personal injury.
- Before working on or disconnecting any of the fuel tubes or fuel system components, relieve the fuel system pressure to prevent accidental spraying of fuel. Fuel in the fuel system remains under high pressure, even when the engine is not running. Failure to follow this instruction may result in serious personal injury.

Fuel Tank Strap Bolt Replacement

GM/Chevrolet Procedure

- 1) Shut down the engine, chock wheels, set parking brake, make sure shifter is in Park or Neutral, and the ignition switch is off.

IMPORTANT: Both bolts must be replaced with GM parts (no aftermarket parts).

- 2) Remove the fuel cap.

NOTE: The existing bolts in the straps holding the fuel tank must be discarded and replaced with new bolts from the manufacturer. See **Figure 1** for how the tank is mounted.

- 3) Raise the bus enough to be able to access the bolts and fuel tank. A lift will be fine as long as you have a support for the fuel tank tall enough to support the tank while working on it.
- 4) Bring the support/jack under tank and center to support the weight.

Recall Campaign

January 2015

FL675A-C

NHTSA # 14V-760 (School Bus)

NHTSA # 14V-759 (Non-School Bus)

Transport Canada 14-549 (School Bus)

- 5) While it is supported, remove the first bolt that holds one of the straps. **Do not remove both straps at the same time.** Be careful of the strap as it will drop down.
- 6) Push the strap back up into place. Insert a new bolt (GM P/N 11610209) and tighten to 15 ft. lbs.
- 7) Repeat with second bolt/strap, replacing the bolt with a new factory bolt.
- 8) Verify the tank is mounted securely and there are no kinks or pinches in the fuel lines or electrical harnesses. Once verified remove the support and return the bus to the ground.

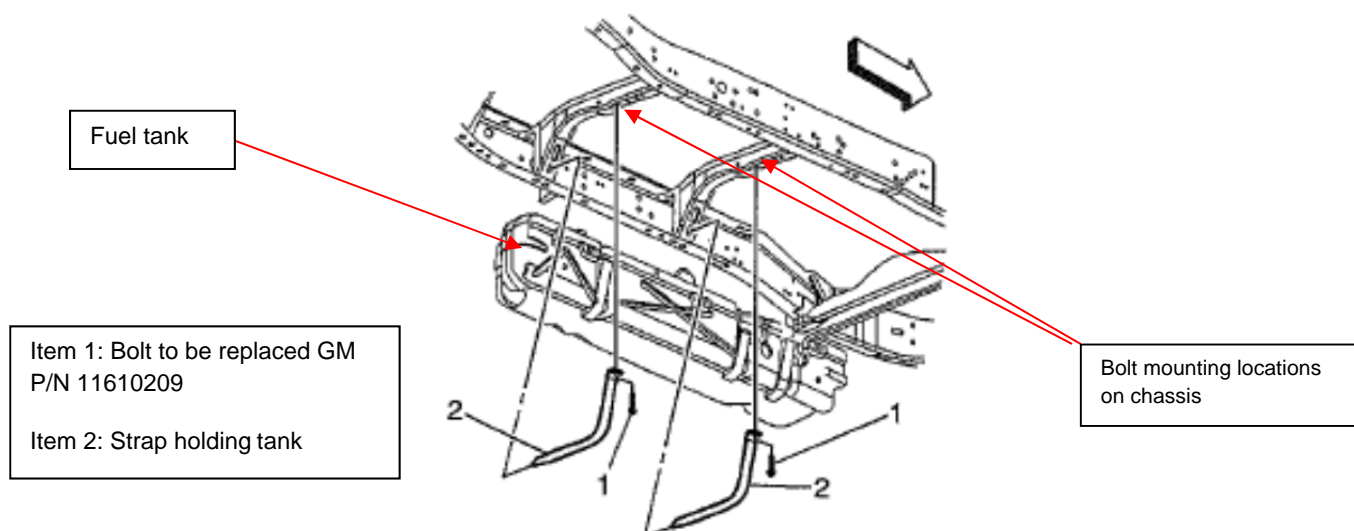

Figure 1, GM Fuel Tank Bolt Locations

Ford Procedure

- 1) Shut down the engine, chock wheels, set parking brake, make sure shifter is in Park or Neutral, and the ignition switch is off.

IMPORTANT: Both bolts/nuts must be replaced with Ford parts (no aftermarket parts).

- 2) Remove fuel cap.
- 3) Raise bus enough to be able to access the bolts and fuel tank. A lift will be fine as long as you have a support for the fuel tank tall enough to support the tank while working on it.
- 4) Bring the support/jack under tank and center to support the weight.
- 5) While it is supported, remove the first bolt and nut that holds one of the brackets. **Do not remove both brackets at the same time.** Be careful of the bracket as it will drop down.
- 6) Push the bracket back to the original location and insert a bolt (Ford P/N N803892-S439) and nut (Ford P/N N802073-S441) and tighten to 18 ft-lbs.
- 7) Repeat with the second bolt/bracket.
- 8) Verify the tank is mounted securely and there are no kinks or pinches in the fuel lines or electrical harnesses. Once verified remove the support and return the bus to the ground.



Memorandum

To: All Thomas Dealers

From: Greg Elmore

Subject: FL675A-C NHTSA# 14V-760 - Mino Fuel Tank Straps

Date: February 20, 2015

The recent release of our recall for Minotour fuel tank straps has experienced a part supply challenge from GM. We are working with GM's distribution channels to provide parts through their distribution network and to accelerate the replenishment of inventory. Last week we were informed that inventory will be available to their dealer network the week of February 23rd.

Please review the units identified in the recall within your AOR to determine your inventory required to complete the recall. We anticipate GM will make inventory available shortly, so work through your local GM dealer to secure your inventory requirements for performing the recall

If you have any questions contact your District Service Manager.

Sincerely,
Greg Elmore