

FLA COE
FLB COE
FLD Conventional
Business Class
FLC 112 Conventional

Century Class Conventional
Argosy COE
Cargo
Columbia

122SD and Coronado
Business Class M2
> Cascadia
108SD/114SD

**Freightliner
Service Bulletin**

Description of Revisions: *This bulletin replaces the version dated April 2015. Information is added about a camera mounting training aid provided by "DTNA Custom Built Training Aids" that can be used to mount the camera as an alternative to the mounting procedure described in this bulletin.*

General Information

Use the instructions in this bulletin to replace the Detroit Assurance Lane Departure Warning (LDW) camera.

Parts

Refer to [Table 1](#) for camera cover and base part numbers.

Camera Mounting Assembly Parts	
Description	Part Number
Cover – Camera, Global Radar	18-67468-000
Cover – Camera Base, Global Radar	A18-67911-000

Table 1, Camera Mounting Assembly Parts

NOTE: A camera mounting training aid has been designed by "DTNA Custom Built Training Aids" and is available through the *Aftermarket Resource Center* (ARC) website. The training aid can be used as an alternative to the mounting procedure described in this bulletin. The order form for the tool can be accessed by clicking the "Training Aids" link located on the lower right-hand side of ARC's home page, then clicking "Detroit Camera Mounting Tool Order Form" on the right-hand side of the page. It is still necessary to order the camera mounting assembly parts described in [Table 1](#) before the camera can be mounted using this tool.

Installing the Detroit LDW Camera

1. Park the vehicle and apply the parking brakes.
2. Run the engine until the air system is fully charged, then shut down the engine and chock the tires.

IMPORTANT: Completely clean the area where the camera will be mounted. If the windshield is not clean and free of grease and dust, the camera may not properly adhere to the windshield surface.

3. Clean the windshield mounting surface with IPA wipe (50/50 mix of isopropyl alcohol and water) or equivalent cleaner. Use a clean towel, and make sure the windshield surface is completely clean and free of grease and dust.
4. Create the template included with this bulletin.

IMPORTANT: When printing the template, make sure that the "Actual Size" radio button is selected under the "Size" tab, the "Auto portrait/landscape" radio button is selected under the "Orientation" heading, and that the "1-sided" radio button is selected on the properties screen. See [Fig. 1](#) and [Fig. 2](#).

- 4.1 Print the template provided on the last page of this bulletin.

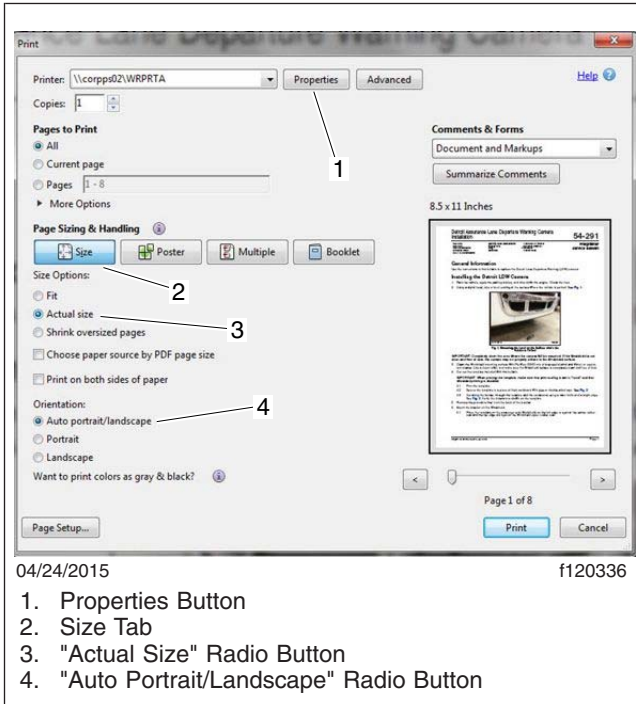

Fig. 1, Print Screen

- 04/24/2015 f120336
1. Properties Button
 2. Size Tab
 3. "Actual Size" Radio Button
 4. "Auto Portrait/Landscape" Radio Button

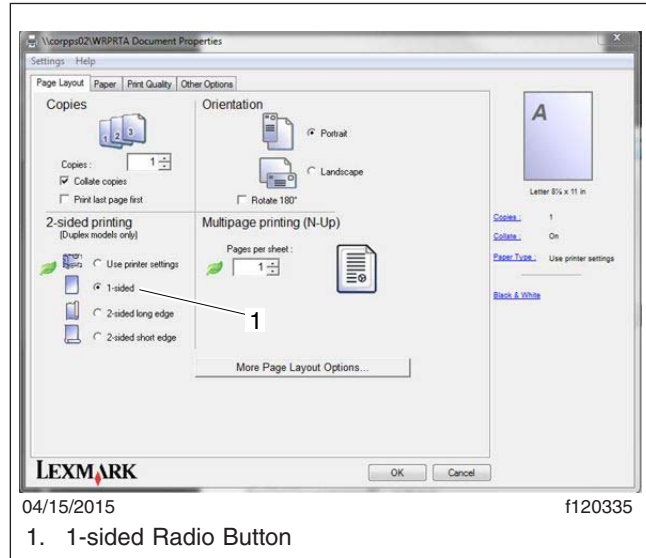

Fig. 2, Document Properties Screen

- 04/15/2015 f120335
1. 1-sided Radio Button

- 4.2 Using a ruler, verify the length of the printed ruler graphic on the template. If the length of the ruler graphic does not measure accurately, the template did not scale properly. Repeat this step until the markings on the printed ruler match those of the ruler in hand.
 - 4.3 Secure the template to a piece of thick cardboard with glue or tape. See [Fig. 3](#).
 - 4.4 Cut along the border, through the template and the cardboard, using a razor knife and straight edge. See [Fig. 4](#). Verify the dimensions shown on the template.
 5. Using a digital level, take a level reading of the surface where the vehicle is parked. See [Fig. 5](#).
 6. Position the template on the passenger-side windshield, so the left edge is against the center rubber seal and the top edge sits against the windshield upper rubber seal, then tape the template to the windshield.
- IMPORTANT:** Do not re-use the camera base. If the windshield is being replaced, or other service is performed that requires the removal of the camera base, a new camera base must be installed.
7. Remove the protective liner from the back of the camera base.
 8. Install the camera base on the windshield.
 - 8.1 Hold the digital level used in step 5 up to the tabs on the camera base. While holding the digital level on the base, hold the bottom of the camera base away from the windshield glass and align the top of the camera base with the template. While maintaining zero level, lower the bottom of the camera base until it contacts the windshield. See [Fig. 6](#).

FLA COE
FLB COE
FLD Conventional
Business Class
FLC 112 Conventional

Century Class Conventional
Argosy COE
Cargo
Columbia

122SD and Coronado
Business Class M2
> Cascadia
108SD/114SD

**Freightliner
Service Bulletin**

- 8.2 Verify proper alignment of the camera base using the dimensions shown in [Fig. 7](#). Hold the digital up to the tabs on the camera base. See [Fig. 8](#). The level reading should be the same as the reading taken of the surface where the vehicle is parked (± 0.4 degrees, with a maximum spec of ± 1.5 degrees). If the base is aligned correctly, continue with step 9. If the base is not aligned correctly, remove it immediately before it cures and repeat steps 8.1 and 8.2.
9. Apply pressure on the base for 30 seconds, then wait 15–30 minutes for the camera base adhesive to set.
10. Connect the camera to the VRDU (Video Radar Detection Unit).
11. Fit the top of the camera into the two tabs on the camera base. See [Fig. 9](#).
- IMPORTANT:** Take care when snapping the camera into the lower mounting notch. If the notch is damaged, the camera base must be replaced.
12. Tilt the bottom of the camera forward until it snaps into the lower mounting notch. See [Fig. 10](#).
13. Attach the camera cover to the base by first aligning the bottom mounting tabs then gently rotating the cover upwards, taking care to position the connector cable so that it feeds through the opening at the top of the cover.

Warranty

This is an informational bulletin only. Warranty does not apply.

Freightliner Service Bulletin

FLA COE
FLB COE
FLD Conventional
Business Class
FLC 112 Conventional

Century Class Conventional
Argosy COE
Cargo
Columbia

122SD and Coronado
Business Class M2
> Cascadia
108SD/114SD

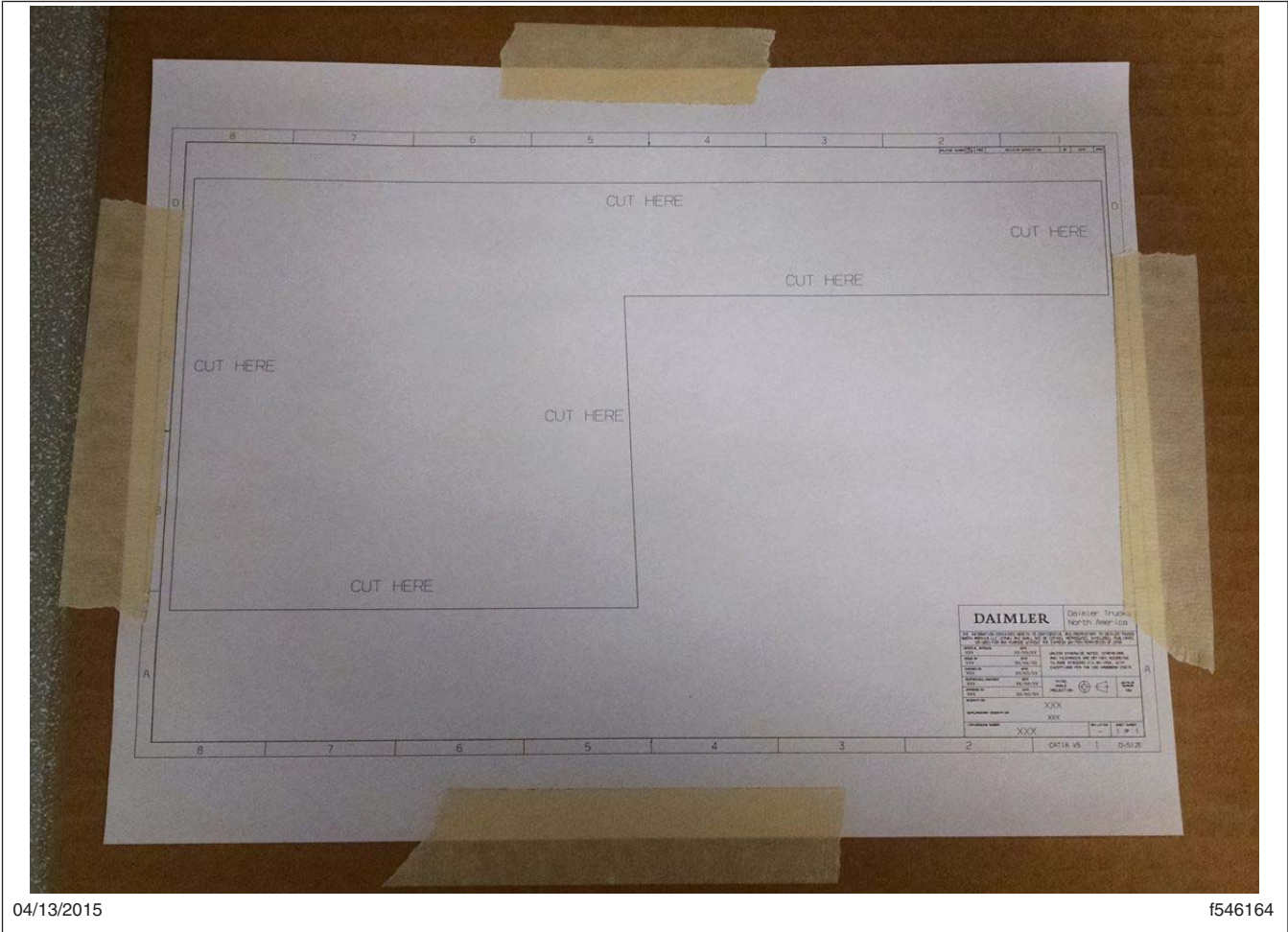

04/13/2015

f546164

Fig. 3, Template Taped to Cardboard

Detroit Assurance Lane Departure Warning Camera Installation

54-291

FLA COE
FLB COE
FLD Conventional
Business Class
FLC 112 Conventional

Century Class Conventional
Argosy COE
Cargo
Columbia

122SD and Coronado
Business Class M2
> Cascadia
108SD/114SD

**Freightliner
Service Bulletin**

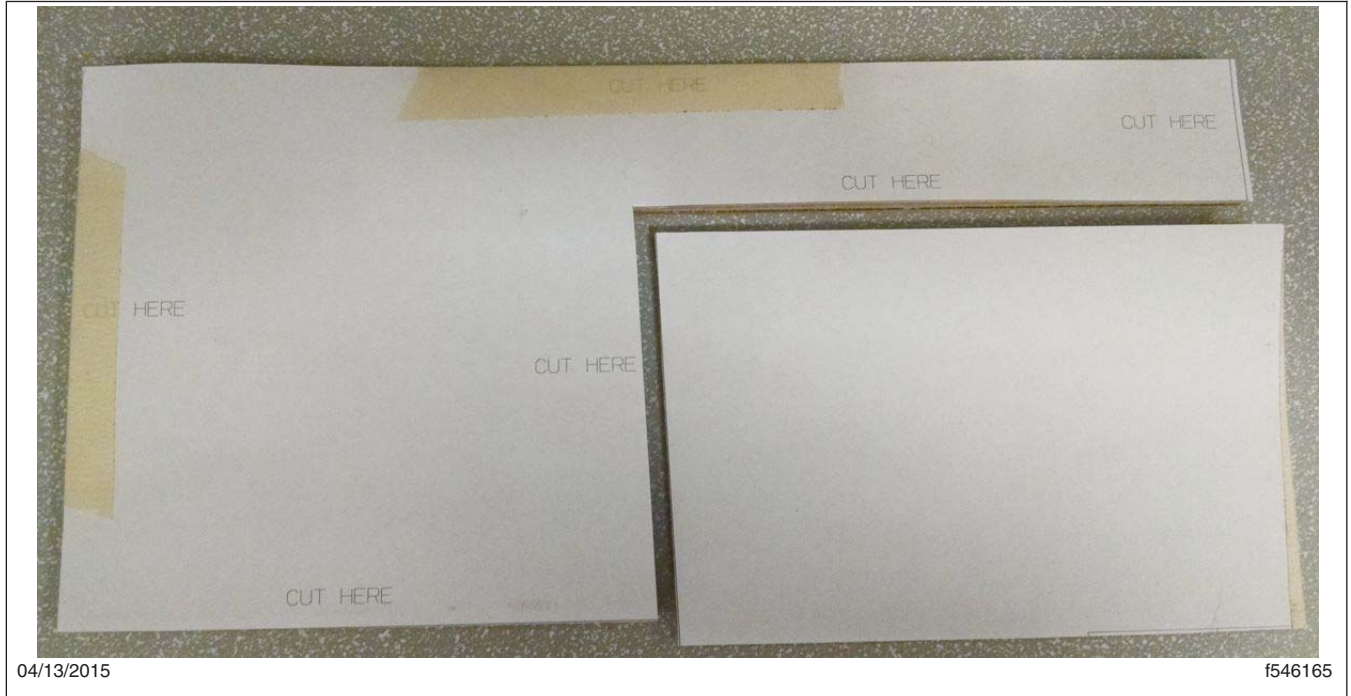

Fig. 4, Template Cut with a Razor Knife



Fig. 5, Measuring the Level on the Surface where the Vehicle is Parked

Freightliner Service Bulletin

FLA COE
FLB COE
FLD Conventional
Business Class
FLC 112 Conventional

Century Class Conventional
Argosy COE
Cargo
Columbia

122SD and Coronado
Business Class M2
> Cascadia
108SD/114SD



Fig. 6, Mounting the Camera Base using the Template

Detroit Assurance Lane Departure Warning Camera Installation

54-291

FLA COE
FLB COE
FLD Conventional
Business Class
FLC 112 Conventional

Century Class Conventional
Argosy COE
Cargo
Columbia

122SD and Coronado
Business Class M2
> Cascadia
108SD/114SD

Freightliner Service Bulletin

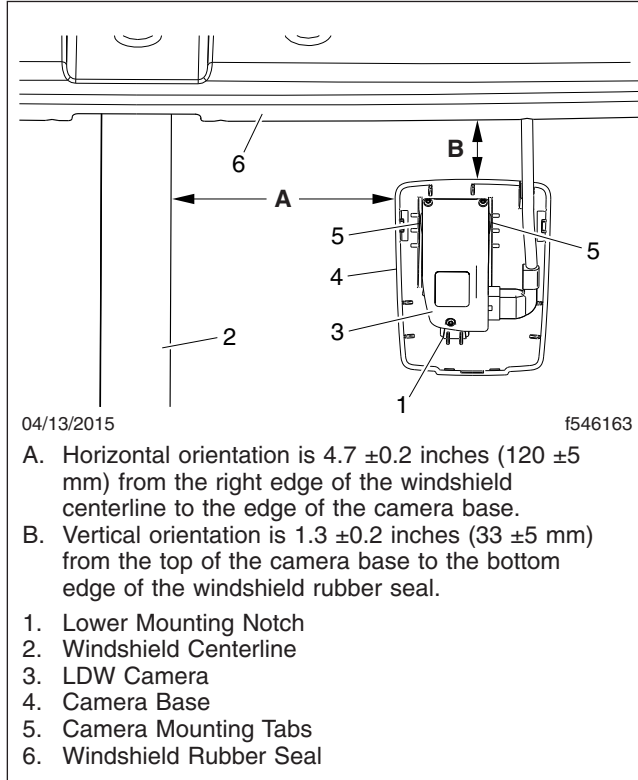

Fig. 7, Installing the Camera Base



Fig. 8, Aligning the Base with a Digital Level

Freightliner Service Bulletin

FLA COE
FLB COE
FLD Conventional
Business Class
FLC 112 Conventional

Century Class Conventional
Argosy COE
Cargo
Columbia

122SD and Coronado
Business Class M2
> Cascadia
108SD/114SD



Fig. 9, Camera Base Tabs

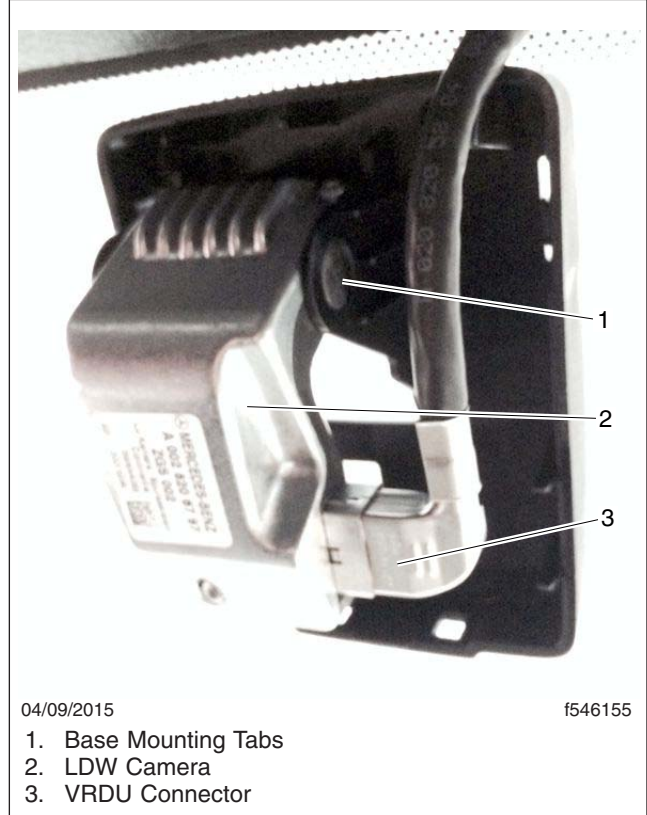

Fig. 10, LDW Camera Installed

