



Service Bulletin

TECHNICAL

Subject: Information for No Start Due to Inoperative LPG Fuel Pump Resulting from Upfitter Modifications

Models: 2012-2015 Chevrolet Express
2012-2015 GMC Savana
Equipped with Liquefied Petroleum Gas (LPG) – RPO KO7

This Bulletin has been revised to change connector callout X305 to connector callout X350. Please discard Corporate Bulletin Number 14-06-04-002A.

Condition

Some customers may comment that their vehicle will not start. They may also comment that the condition is intermittent.

Cause

An inoperative LPG fuel pump may be caused by an improperly connected G400 terminal. This condition may be the result of one or more of the following:
The necessity of the upfitter removing and repositioning the G400 terminal from its original factory location to another location on the chassis frame rail.

Specifically:

- The upfitter not properly preparing the chassis frame surface area selected for the new ground location for good electrical contact.
- The upfitter not properly preparing the electrical contact area of the G400 terminal and not using a new replacement fastener with a conductive finish to secure the terminal.
- The upfitter not properly finishing the area to provide corrosion control.
- Intermittent conditions and poor connections at connector X350 as a result of any of the preceding G400 terminal conditions.

Correction

Notice: When replacing an LPG fuel pump that has failed, the following **MUST** be performed to ensure the integrity of G400 and connector X350:

Correction for G400

- For information on correctly performing an electrical ground repair, refer to the latest version of Corporate Bulletin 10-08-45-001: Information for Electrical Ground Repair - Use New Replacement Fasteners with Conductive Finish.
- For information on correctly performing the procedures for prepping and corrosion control, refer to the latest version of PI0564: Wax Coating on Frame Peeling, Metal Shows Corrosion/Rusting.
- For information on selecting the proper products and coatings that GM believes to be reliable, refer to the latest version of Corporate Bulletin 01-08-51-003: Application of Anti-Corrosion Materials.

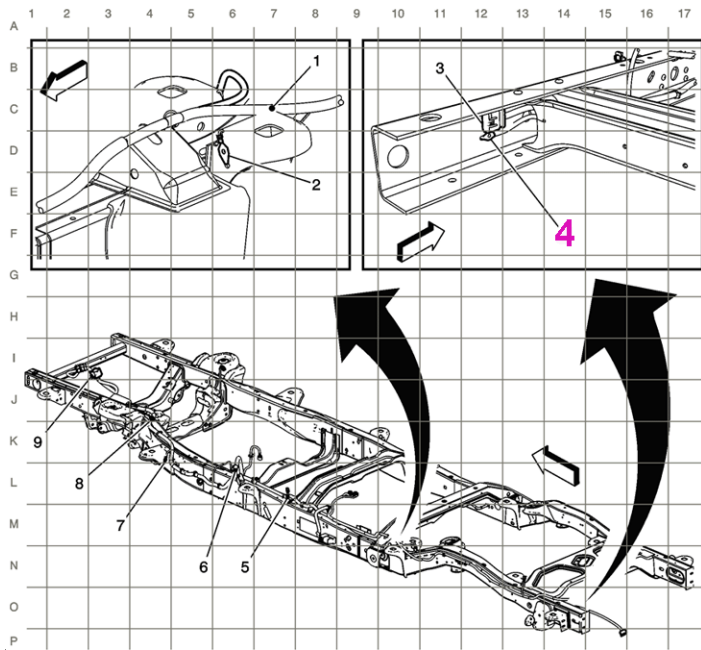

1. Review the original OEM location of G400 (4) in the graphic. The new G400 location selected by the upfitter will be in this general area of the chassis frame.



2. Review the graphics of the several new G400 locations that were possibly selected for use by the upfitter on the chassis frame in order to become familiar with the various locations.
3. Using GM approved residue-free solvent or equivalent, remove any grease from the G400 terminal.
4. Disconnect and remove the G400 terminal from the chassis frame.
5. Carefully remove any corrosion from both sides of the G400 terminal.
6. Using GM approved residue-free solvent or equivalent, remove any grease from the area and allow to dry.
7. Carefully remove any factory coating from the area until clean bare metal is visible.
8. Prep the repair area, as outlined in the Recommendations/Instructions in the latest version of PI0564: Wax Coating on Frame Peeling, Metal Shows Corrosion/Rusting.
9. Select a conductive fastener for the repair. Refer to the latest version of Bulletin 10-08-45-001: Information for Electrical Ground Repair - Use New

Replacement Fasteners with Conductive Finish.

10. Using a small brush, apply Dielectric Lubricant to both sides of the G400 terminal, install and secure as needed.
11. Perform the corrosion control procedure as outlined in the Recommendations/Instructions in the latest version of PI0564.

Correction for Connector X350

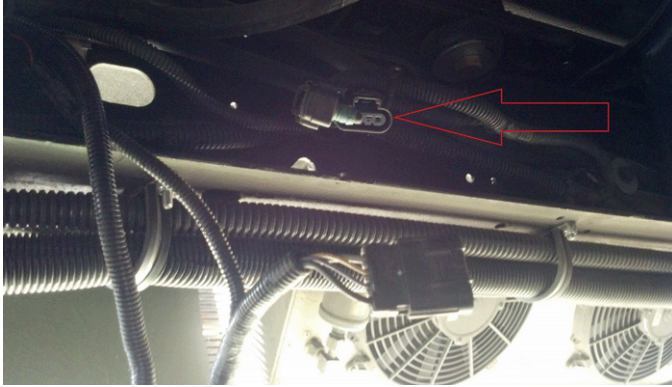

1. Disconnect the LPG fuel pump connector X350.



2. The X350 connector is shown with the plastic insert in position and then removed. Inspect the X350 connector for intermittent conditions and poor connections. Refer to Testing for Intermittent Conditions and Poor Connections in SI.
 - ⇒ If intermittent conditions and poor connections are found, repair as needed. Refer to Repairing Connector Terminals, Connector Repairs and Wiring Repairs in SI.

GM bulletins are intended for use by professional technicians, NOT a "do-it-yourselfer". They are written to inform these technicians of conditions that may occur on some vehicles, or to provide information that could assist in the proper service of a vehicle. Properly trained technicians have the equipment, tools, safety instructions, and know-how to do a job properly and safely. If a condition is described, DO NOT assume that the bulletin applies to your vehicle, or that your vehicle will have that condition. See your GM dealer for information on whether your vehicle may benefit from the information.



WE SUPPORT VOLUNTARY TECHNICIAN CERTIFICATION