



Service Bulletin

PRELIMINARY INFORMATION

Subject: Front Shock Mount Bracket Crack (Install Reinforcement)

Models: 2006-2015 Chevrolet Express
2006-2015 GMC Savana
with RPO ANC, YF2, YF1 or B3D (Cutaway Body)

This PI has been revised to add the 2013-2015 Model Years and update Step 16. Please discard PI1080.

Condition/Concern



Some customers may comment that a crack has developed on the spring mount area of the front shock absorber mounting bracket.

Recommendation/Instructions

A metal reinforcement plate has been developed to correct this condition and prevent future concerns in this area.

Use the following steps to install the shock mount bracket reinforcement:

Note: Clean and de-grease the area at this point if possible. Use white spray paint to locate and identify the position of the adjustable components of the suspension and steering systems. This will aid in locating the components during reassembly.

1. Raise and support the vehicle. Refer to Lifting and Jacking the Vehicle in SI.
2. Remove the tire and wheel. Refer to Tire and Wheel Removal and Installation in SI.
3. Remove the wheelhouse splash shield. Refer to Wheelhouse Splash Shield Replacement in SI.
4. Disconnect the wheel speed sensor at the chassis connector and remove the harness attachments.

Important: When removing the upper control arm, is not necessary to separate the components at the lower ball joint or to remove the wheel hub. The steering knuckle, hub and lower control arm can remain attached to the vehicle.

5. Remove and support the front brake caliper as follows:

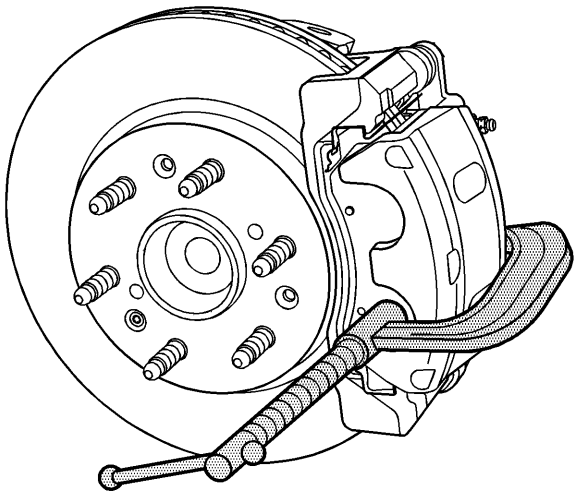

- 5.1. Install two large C-clamps over the top of the caliper housing and against the back of the outboard brake pad.
- 5.2. Slowly tighten the C-clamps until the caliper pistons are pushed completely into the caliper bores.
- 5.3. Remove the C-clamps.

Note: Remove the brake caliper bracket and the brake caliper as an assembly.

- 5.4. Remove the two brake caliper bracket mounting bolts.

Caution: Support the brake caliper with heavy mechanic wire, or equivalent, whenever it is separated from its mount and the hydraulic flexible brake hose is still connected. Failure to support the caliper in this manner will cause the flexible brake hose to bear the weight of the caliper, which may cause damage to the brake hose and in turn may cause a brake fluid leak.

- 5.5. Remove the caliper and bracket assembly and support with heavy mechanics wire or equivalent.

6. Remove the brake rotor.
7. Remove the front spring. Refer to Front Spring Replacement in SI.
8. Disconnect the upper ball joint from the upper control arm. Refer to Steering Knuckle Replacement (RWD) in SI.
9. Remove the upper control arm. Refer to Upper Control Arm Replacement in SI.
10. Using a general purpose adhesive remover, remove any factory protective coatings and clean the area to be repaired. If necessary, use a grinder to remove any rust or scale.



11. Inspect the spring mounting area for cracks. If any cracks are detected, repair as required. Dress any crack repair to ensure the service part will fit flush.

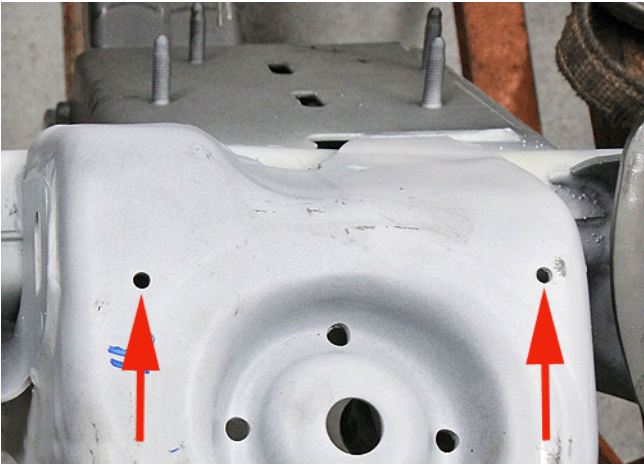

12. Place two 6 mm x 16 mm pan head machine screws in the speed sensor wiring harness retainer holes located on the top of the bracket.

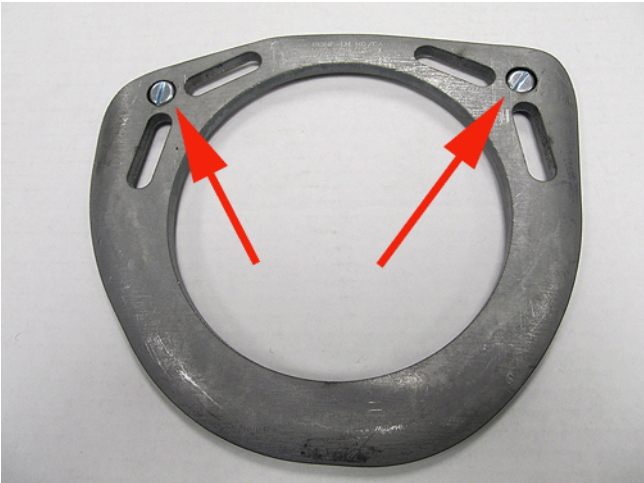

13. Position the reinforcement on the vehicle and position the screw heads through the two round alignment holes.

14. With the reinforcement positioned, clamp in place.

15. Weld the reinforcement to the bracket.

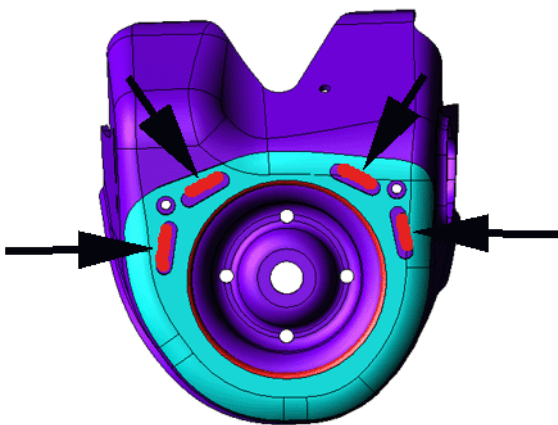

- Weld the four slots.

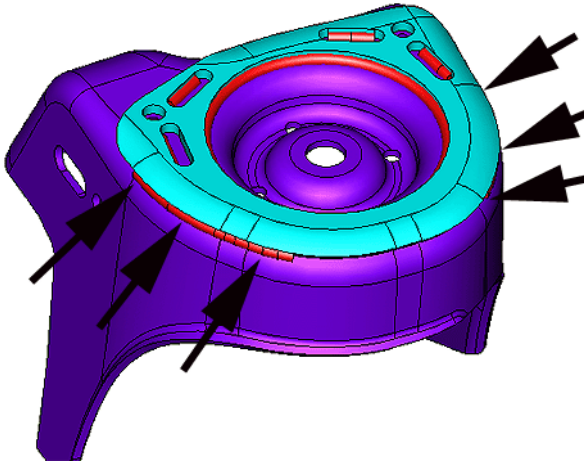

- Weld the outer edge of the reinforcement leaving a gap in the center as shown. To avoid heat build up, stitch weld along the entire joint. Make 25 mm (1 in) welds along the seam with 25 mm (1 in) gaps between, then go back and complete the weld.

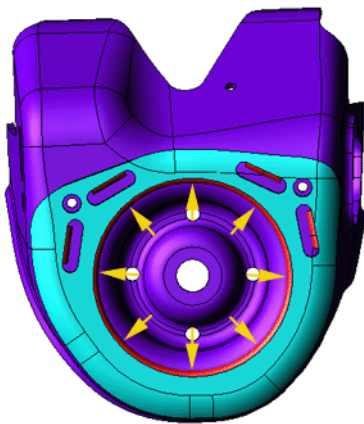

- Weld the entire circumference of the inner ring. To avoid heat build up, stitch weld along the entire joint. Make 25 mm (1 in) welds along the seam with 25 mm (1 in) gaps between, then go back and complete the weld.
16. Before proceeding to the next step: if the vehicle is model year 2006-2012, review PI0489A to verify the reinforcements outlined in the bulletin have been installed. If the vehicle is model year 2013-2015, proceed to step 17.

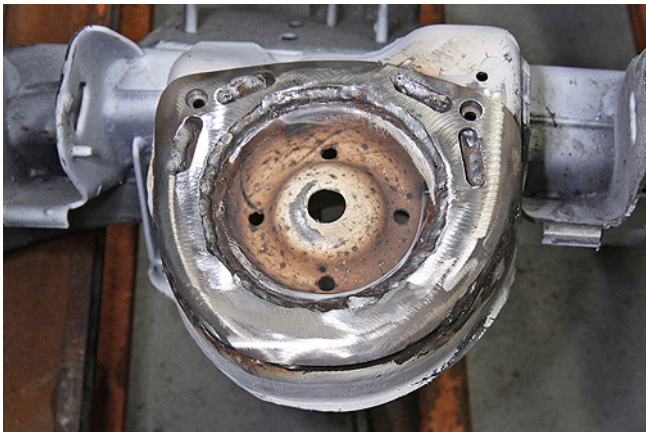

17. Clean and prepare all of the welded surfaces.
18. Apply the required sealers and anti-corrosion materials to the repair area. Refer to Anti-Corrosion Treatment and Repair in SI.
19. Reinstall the upper control arm. Refer to Upper Control Arm Replacement in SI.
20. Reinstall the front spring. Refer to Front Spring Replacement in SI.
21. Reattach the upper ball joint. Refer to Steering Knuckle Replacement (RWD) in SI.
22. Reinstall the front brake caliper, bracket and rotor.

23. Reconnect the wheel speed sensor at the chassis connector and reinstall the harness attachments.
24. Reinstall the wheelhouse splash shield. Refer to Wheelhouse Splash Shield Replacement in SI.
25. Reinstall the tire and wheel. Refer to Tire and Wheel Removal and Installation in SI.
26. Repeat the above steps on the opposite side of the vehicle.

Parts Information

Part Number	Description
23208009	LH Spring Seat Reinforcement Bracket
23208010	RH Spring Seat Reinforcement Bracket

Warranty Information

For vehicles repaired under warranty, use:

Labor Operation	Description	Labor Time
1480018*	Front Shock Mount Bracket Reinforcement Installation	3.5 hrs

*This is a unique Labor Operation for Bulletin use only. It will not be published in the Labor Time Guide.

GM bulletins are intended for use by professional technicians, NOT a "do-it-yourselfer". They are written to inform these technicians of conditions that may occur on some vehicles, or to provide information that could assist in the proper service of a vehicle. Properly trained technicians have the equipment, tools, safety instructions, and know-how to do a job properly and safely. If a condition is described, DO NOT assume that the bulletin applies to your vehicle, or that your vehicle will have that condition. See your GM dealer for information on whether your vehicle may benefit from the information.



WE SUPPORT VOLUNTARY TECHNICIAN CERTIFICATION