



Service Bulletin

PRELIMINARY INFORMATION

Subject: Rapid Flashing Turn Signals During Operation

Models: 2013-2015 GMC Acadia

Attention: This PI also applies to any of the above models that may be Middle East Export vehicles.

Condition/Concern

Some customers may comment while operating the turn signals, the signal will flash rapidly.

This condition may be caused by poor terminal tension in the stop and tail lamp connectors.

Recommendation/Instructions

If this condition exists, removal of the affected tail lamp assembly to perform a terminal tension test to the stop and tail lamp connector is necessary.

Follow the instructions below:

Tail Lamp Connector Terminal Tension Testing

1. Remove the affected tail lamp assembly. Refer to the Tail Lamp Replacement (Acadia) in SI.

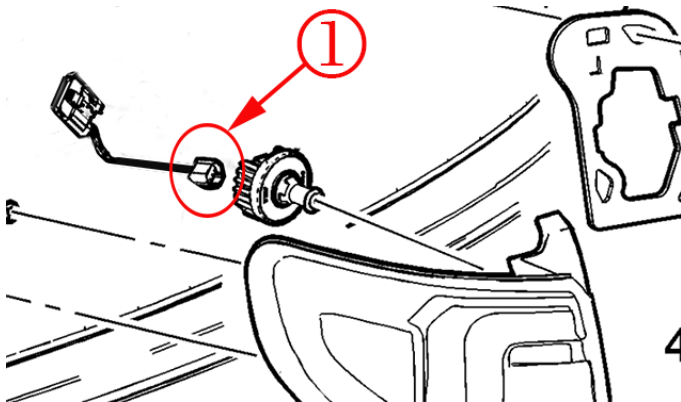

2. Disconnect the stop and tail lamp connector (1) and test probe each terminal for poor tension with J-35616-64B (L-BU).
3. If the terminal tension is within specification, continue diagnoses. Refer to the appropriate service information.
4. If any of the terminals have poor tension, replace the affected tail lamp as an assembly.
5. After the replacement of the tail lamp assembly, verify the condition has been corrected.

Parts Information

Part Number	Description
23236014 (Left Side)	Tail Lamp Assembly

23236015 (Right Side)	Tail Lamp Assembly
--------------------------	--------------------

Warranty Information

For vehicles repaired under the Bumper-to-Bumper coverage (Canada Base Warranty coverage), use the following labor operation. Reference the Applicable Warranties section of Investigate Vehicle History (IVH) for coverage information.

Labor Operation	Description	Labor Time
2680348*	Tail Lamp Assembly Test and Replace	0.3 hr
Add	Both Tail Lamp Assemblies Test and Replace	0.2 hr

*This is a unique Labor Operation for Bulletin use only. It will not be published in the Labor Time Guide.

GM bulletins are intended for use by professional technicians, NOT a "do-it-yourselfer". They are written to inform these technicians of conditions that may occur on some vehicles, or to provide information that could assist in the proper service of a vehicle. Properly trained technicians have the equipment, tools, safety instructions, and know-how to do a job properly and safely. If a condition is described, DO NOT assume that the bulletin applies to your vehicle, or that your vehicle will have that condition. See your GM dealer for information on whether your vehicle may benefit from the information.



WE SUPPORT VOLUNTARY TECHNICIAN CERTIFICATION