



# Service Bulletin

## PRELIMINARY INFORMATION

**Subject:** Brake Squeal or Squeak Noise Intermittently on Initial Brake Applies

**Models:** 2013-2015 Cadillac ATS Equipped with RPO J55  
2013-2015 Cadillac XTS Equipped with RPO J64  
2014-2015 Cadillac CTS Sedan (VIN A) Equipped with RPO J55 or J56

**Attention:** This PI also applies to any of the above models that may be Export vehicles.

*This PI has been revised to remove the Regal GS and SS models, update the Parts and Warranty Information and the procedure under Recommendation/Instructions. Please discard PI0917E.*

### Condition/Concern

Some customers may comment on a squeal or squeak noise from the front brakes. This condition normally only occurs on initial brake applications after the vehicle has sat for an extended time. The condition occurs typically under light braking, in speeds under 16km/h (10 mph). After 1-6 brake applies, or after braking at higher speeds, the noise no longer occurs. This condition may occur more often in high humidity conditions.

### Recommendation/Instructions

**Important:** Do not apply the copper paste to the back of the backing plate.

Replace the front brake pads and apply a coat of copper paste to completely cover the pad backing plate abutments on each end. The paste should not extend onto the friction material. Follow the instructions listed below.

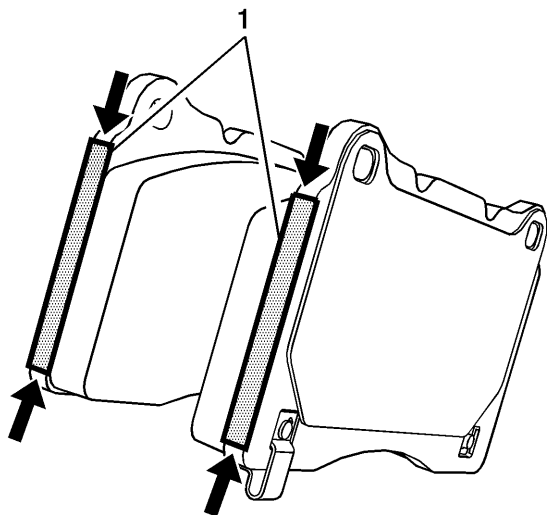

1. Abutment Area

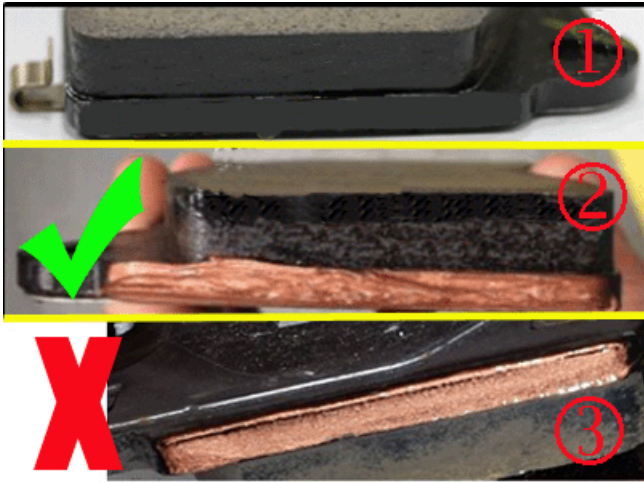

1. *Cleaned Abutment Area*
2. *Correct Amount of Copper Paste*
3. *Incorrect Amount of Copper Paste*

1. Remove the front disc brake pads and discard. Refer to the Front Disc Brake Pads Replacement in SI.
2. Wipe clean both ends of the abutment area of the calipers.
3. Apply approximately 0.10 g (0.0035 oz) of copper paste to each end of the disc brake pad abutments that contact the brake caliper bracket.  
**Note:** Avoid a light apply of the paste as illustrated above.
4. Install the front disc brake pads. Refer to the Front Disc Brake Pads Replacement in SI.

## Parts Information

Part Number	Description	Qty
19303310 (In Canada, use 19303311)	Lubricant	1
23271117	PAD KIT- FRT DISC BRK	1

## Warranty Information

For vehicles repaired under the Bumper-to-Bumper coverage (Canada Base Warranty coverage), use the following labor operation. Reference the Applicable Warranties section of Investigate Vehicle History (IVH) for coverage information.

Labor Operation	Description	Labor Time
2420150	Front Disc Brake Pads Replacement	Use Published Labor Operation Time

GM bulletins are intended for use by professional technicians, NOT a "do-it-yourselfer". They are written to inform these technicians of conditions that may occur on some vehicles, or to provide information that could assist in the proper service of a vehicle. Properly trained technicians have the equipment, tools, safety instructions, and know-how to do a job properly and safely. If a condition is described, DO NOT assume that the bulletin applies to your vehicle, or that your vehicle will have that condition. See your GM dealer for information on whether your vehicle may benefit from the information.



WE SUPPORT VOLUNTARY TECHNICIAN CERTIFICATION