



Service Bulletin

INFORMATION

Subject: 2016 Chevrolet Camaro New Model Features

Brand:	Model:	Model Year:		VIN:		Engine:	Transmission:
		From:	To:	From:	To:		
Chevrolet	Camaro	2016	2016	All	All	V6 3.6L — RPO LGX V8 6.2L — RPO LT1	Hydra-Matic™ Automatic 8-Speed 8L45 — RPO M5T (LT Model) Hydra-Matic™ Automatic 8-Speed 8L90 — RPO M5U (SS Model) Manual 6 Speed Tremec TR3160 — RPO M13 (LT Model) Manual 6 Speed Tremec TR6060 — RPO MM6 (SS Model)

Involved Region or Country	North America and N.A. Export Regions
----------------------------	---------------------------------------

Overview



Bulletin Purpose

This is a special bulletin to introduce the sixth-generation 2016 Chevrolet Camaro. The purpose of this bulletin is to help the Service Department Personnel become familiar with the vehicle's new features and to describe some of the action they will need to take to ensure that they are able to service this vehicle.

About the Car

The 2016 Camaro is offered as a coupe in 4 models: 1LT, 2LT, 1SS and 2SS. The first vehicles delivered to customers are the coupe models, the SS with the V8 6.2L or the LT with the V-6 3.6L. The Camaro Convertible and models with the 2.0L Turbo engine will begin shipping in early 2016 depending on the Region

The sixth-generation 2016 Camaro offers higher levels of performance, technology and refinement and is designed to maintain the sporty car segment leadership it has earned over the past six Model Years.

The Camaro now shares the same light, rear wheel drive architecture as the Cadillac ATS and CTS sport sedans. Approximately 70 percent of the architectural components are unique to the Camaro. Vehicle mass has been reduced between 223–390 pounds (101–177 kg), depending on the model, creating a more nimble, responsive driving experience. Even with the reduced weight, using extensive computer-aided engineering, structural rigidity was increased by 28 percent. The Camaro will offer a noticeable change in driving feel with better balance, improved steering feel and precise turning, more nimbleness and improved braking. With the lighter, stiffer architecture and more powerful engines, the sixth-generation Camaro SS delivers better lap times than the fifth-generation's track-focused Camaro 1LE package.



The front of the Camaro is defined by a cross-car grille/headlamp aperture, a signature cue that dates to the first-generation Camaro. The new, expressive execution gives the Camaro a stronger, more determined face.



A more expressive take on the taillamps blends the horizontal aesthetic of the first-generation with a dual-element theme and aggressive tapers for a contemporary appearance. SS models have a unique rear spoiler.



The leaner, stiffer platform and slightly smaller dimensions are accentuated by a dramatic, sculpted exterior. The aerodynamically optimized design is the result of 350 hours of wind tunnel testing and results in reducing drag on LT models and improving the downforce on SS models. The exterior contributes to performance through better handling while enhancing efficiency. The aerodynamic driven design uses a subtle “air curtain” on the front fascia which guides air around the wheels to help reduce drag.

All sixth-generation Camaros will benefit from some level of bolt-on bracing. A strategy designed to provide adequate stiffness and help contribute to an improved ride, handling and steering. When comparing the bolt-on bracing between vehicles it is important to make sure that you are comparing *like* models.



The SS hood has functional air vents that help to improve engine cooling and reduce front end lift, while the SS front fascia has integrated brake cooling ducts. Standard HID headlamps on the SS are available on the LT with the RS Appearance Package. LED daytime running lamps are standard on all models.



Inside, a driver-focused cockpit with an available 8-inch (203 mm) diagonal configurable color digital screen that acts as the instrument cluster integrates class-leading technologies, including a new Driver Mode Selector.

Standard on the 2SS and available on the 2LT is a customizable Interior Spectrum Lighting feature, that offers 24 different ambient lighting effects including fade and transition on the dash, door panels and center console. This feature also includes the theatrical “*car show*” mode. When using the key fob and unlocking the vehicle, a lighting pulse will display inside the car. Upon vehicle start-up there is light movement across the car moving outward from the infotainment touchscreen to the doors and occurs for approximately 1.5 seconds. When switching driving modes the same light movement occurs also for approximately 1.5 seconds.

The sculpted dashboard will house an available 8-inch (203 mm) and on the 1LT and 1SS a 7-inch (178 mm) infotainment color touch screen display, able to provide drivers over 20 sources of information with Chevrolet MyLink™. Standard connectivity features include Chevrolet MyLink™ with Apple CarPlay™ capability and OnStar® 4G LTE with Wi-Fi hotspot. Up to seven devices such as smartphones, tablets and laptops can be connected to high-speed internet through the vehicle built-in Wi-Fi hotspot.

A key new feature is the functionality of the 4 air vent trim rings. These air vent trim rings around the center air vents are the functional controls and rotate to adjust temperature and fan speed if equipped with the single-zone HVAC system or independent temperatures for the driver and passenger when equipped with the dual-zone HVAC system.

All models come standard with Passive Entry Passive Start (PEPS).

The 2016 Camaro will be produced at GM's Lansing Grand River assembly plant in Lansing, Mich.

Available Vehicle Packages

The available vehicle packages are a Track Performance Option and an RS Appearance Package:

Track Performance Option (LT Only) — RPO Y4Q

This package includes:

- Engine Oil Cooler — RPO KC4
- Heavy Duty Brake System — RPO J55 (LT has Brembo brakes on the front only).
- Cooling System Extra Capacity — RPO V03
- Cooling System Auxiliary — RPO V18

RS Appearance Package (LT Only) — RPO WRS

This package includes:

- 20" Wheel: 20 X 8.5, ALUMINUM, DESIGN 1 — RPO RQ9, ALUMINUM, DESIGN 3 — RPO RTH or ALUMINUM, DESIGN 4 — RPO RTJ
- Unique Front and Rear Exterior Lighting — RPO T4F, T61
- Fascia and Front Grille
- Lip Spoiler Rear End Panel — RPO D80

Engines

The available engines during the initial vehicle launch period are the V8 6.2L Continuous VVT, DI with AFM — RPO LT1 and the V6 3.6L with Continuous VVT, DI with AFM — RPO LGX.

Engine V8 6.2L — RPO LT1

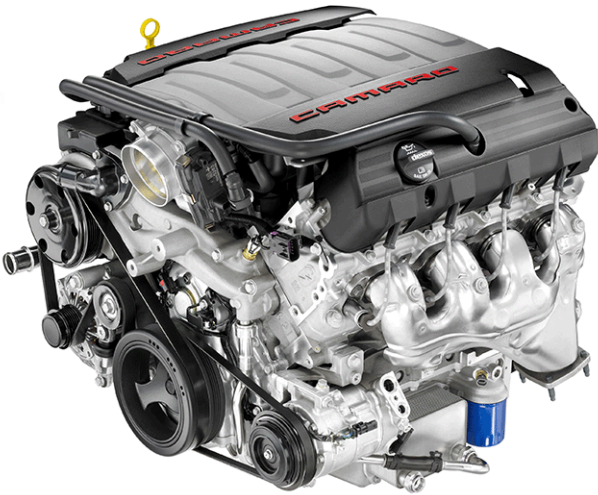
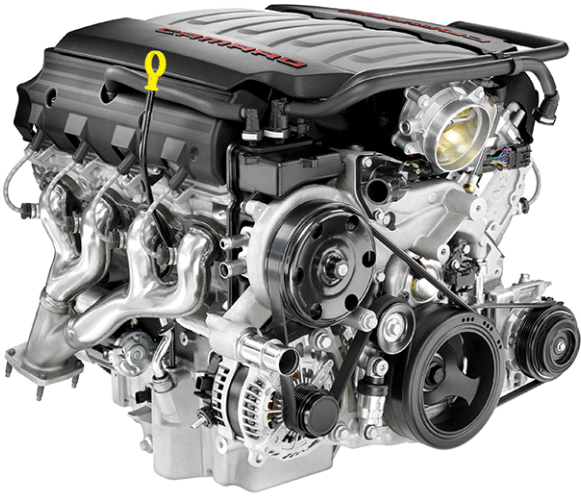

For 2016, the V8 6.2L — RPO LT1 small-block is standard in the Camaro SS versions. The SS equipped with the eight-speed 8L90 automatic transmission — RPO M5U, is capable of 0–60 mph (0–97 km/h) in 4.0 seconds and produces an SAE certified 455 horsepower (339 kW) at 6,000 rpm and 455 lb-ft (617 Nm) of torque at 4,400 rpm.

- **Displacement:** 376 cu in (6,162 cc).
- **Bore and Stroke:** 4.06 x 3.62 in (103.25 x 92 mm).
- **Block Material:** Cast aluminum with cast-in-place iron bore liners.
- **Cylinder Head Material:** Cast aluminum.
- **Valvetrain:** Overhead valve, two valves per cylinder, variable valve timing (VVT) with Active Fuel Management (AFM). AFM disables two cylinders under light throttle conditions to enhance efficiency.
- **Fuel Delivery:** Direct high pressure fuel injection.
- **Compression Ratio:** 11.5:1
- **Exhaust Manifolds:** New tubular “*tri-Y*” type exhaust manifolds.
- **Exhaust Sound:** Each engine has been carefully tuned for a distinctive performance sound. The 6.2L features mechanical sound enhancers - resonators that direct induction noise from the engine bay into the cabin.
- **Dual-Mode Exhaust:** The available dual-mode exhaust features electronically controlled valves that bypass the mufflers under acceleration delivering improved performance.

Engine V6 3.6L — RPO LGX



For 2016, the all-new V6 3.6L — RPO LGX is standard in the Camaro LT versions. The LT can be equipped with the 8-speed 8L45 automatic transmission — RPO M5T or the Manual 6-Speed Tremec — RPO M13. The engine produces an SAE certified 335 horsepower (250 kW) at 6,800 rpm and 284 lb-ft (385 Nm) of torque at 5,300 rpm.

- **Displacement:** 222 cu in (3,640 cc).
- **Bore and Stroke:** 3.74 x 3.37 in (95 x 85.6 mm).
- **Block Material:** Cast aluminum with cast-in-place iron bore liners.
- **Cylinder Head Material:** Cast aluminum.
- **Valvetrain:** DOHC, four valves per cylinder, variable valve timing (VVT) with Active Fuel Management (AFM). AFM disables two cylinders under light throttle conditions to enhance efficiency.
- **Fuel Delivery:** Direct high pressure fuel injection.
- **Compression Ratio:** 11.5:1
- **Exhaust Sound:** Each engine has been carefully tuned for a distinctive performance sound. The 3.6L features mechanical sound enhancers - resonators that direct induction noise from the engine bay into the cabin.
- **Dual-Mode Exhaust:** The available dual-mode exhaust features electronically controlled valves that bypass the mufflers under acceleration delivering improved performance.

dexos® Engine Oil



Ask for and use engine oils that meet the dexos® specification. Engine oils that have been approved by GM as meeting the dexos® specification are marked with either of the dexos1® approved logos that are shown. For additional information, visit this General Motors website: <http://www.gmdexos.com>

Viscosity Grade

Use AC Delco dexos1® synthetic blend SAE 5W-30 viscosity grade engine oil.

In an area of extreme cold, where the temperature falls below -20°F (-29°C) use SAE 0W-30 engine oil. An oil of this viscosity grade will provide easier cold starting for the engine at extremely low temperatures.

Engine Oil Life System

The vehicle features GM's engine oil life system, which better protects engines by recommending oil changes based on a computer software algorithm using actual engine operating conditions and can save the vehicle owner money by avoiding unnecessary oil changes.

Transmissions

- The Camaro LT V6 3.6L can be equipped with the Tremec TR3160 6-speed manual transmission or the Hydra-Matic™ 8-speed 8L45 automatic transmission.
- The Camaro SS V8 6.2L can be equipped with the Tremec TR6060 6-speed manual transmission, now with Active Rev Match or the Hydra-Matic™ 8-speed 8L90 automatic transmission.

Active Rev Match

Camaro SS vehicles equipped with a TR6060 6-speed manual transmission have Active Rev Match (ARM). ARM aids in smoother shifting by matching the engine speed to the next selected gear. By monitoring shift lever and clutch operation, ARM adjusts engine speed to match a calibrated value based on gear selection. On upshifts and downshifts, engine speed will be increased and decreased to match vehicle road speed and transmission gear position. ARM is maintained for a few seconds between shifts, then deactivates if the shift is not completed. The system is activated and deactivated by pressing either of the paddles marked REV MATCH on the steering wheel. The system must be activated with each new ignition cycle.

Powertrain Braking

When driving on steep descents with the shift lever in **D** (Drive) where frequent braking is required, the automatic transmission — RPO 8L45 and 8L90 will downshift a gear to help hold vehicle speed and to reduce brake wear. If the driver continues to press the brake, the transmission will downshift until **3** (third) gear is reached. If the brake is released for some time, the transmission will upshift a gear. If the road levels out and the accelerator pedal is pressed, the transmission will upshift until the appropriate gear is reached. This is a normal operating characteristic.

Tap Shift

Tap Shift allows you to manually control the automatic transmission. To use Tap Shift, the shift lever must be in **D** (Drive). The paddles are on the back of the steering wheel. Tap the left paddle (-) to downshift, and the right paddle (+) to upshift. The Driver Information Center (DIC) display indicates the gear the vehicle is in.

Temporary Tap Shift

Temporary Tap Shift Mode allows brief entry into Tap Shift Mode while in **D** (Drive). Tapping either the upshift or downshift control will place the transmission in Tap Shift Mode. Exit Tap Shift Mode by holding the upshift control for two seconds. The system will return to automatic shifting after seven seconds of driving at a steady speed, or when the vehicle comes to a stop.

Performance Shifting

While driving in Sport Mode and Track Mode (V8 only), if Tap Shift has not been activated, the transmission determines when the vehicle is being driven in a competitive manner. The transmission may remain in a gear longer than it would in the normal driving mode based on throttle input and vehicle lateral acceleration. If there is a rapid reduction in throttle from a heavy throttle position at high rpm, the transmission will maintain the current gear up to near redline rpm. While braking, the transmission will automatically downshift to the next lower gear keeping engine speed above approximately 3,000rpm. If the vehicle is then driven for a short time at a steady speed, and without high cornering loads, the transmission will upshift one gear at a time, until **8** (Eighth) gear. After shifting to **8** gear, or coming to a complete stop, the transmission will return to normal Sport Mode shifting.

Manual Mode — Driver Shift Control

Driver Shift Control (DSC) allows shifting an automatic transmission similar to a manual transmission. While using the DSC feature, the vehicle will have firmer, quicker shifting. You can use this for sport driving or when climbing or descending hills, to stay in gear longer, or to downshift for more power or engine braking. To use the DSC feature:

1. Move the shift lever to the left from **D** into the side gate marked with +/-
2. Press the shift lever forward to upshift or rearward to downshift.

The transmission will only allow the driver to shift into gears appropriate for the vehicle speed and engine rpm. The transmission will not automatically shift to the next lower gear if the engine rpm is too high, nor to the next higher gear when the maximum engine rpm is reached. While in the DSC mode, the transmission will automatically downshift as the vehicle comes to a stop. This will allow for more power during take-off.

Gear Ratios - Tremec TR3160 6-Speed Manual Transmission — RPO M13 (V6 3.6L)

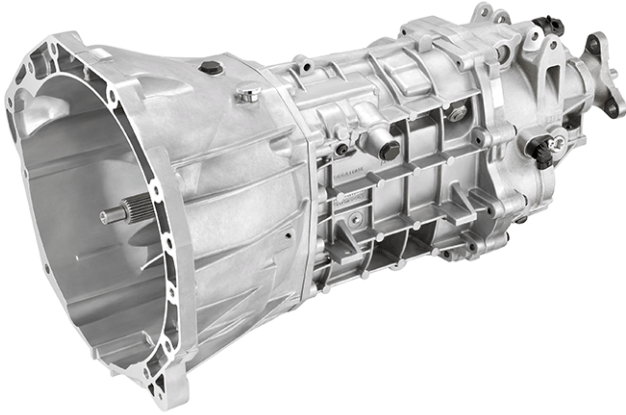

- **First:** 4.40
- **Second:** 2.59
- **Third:** 1.80
- **Fourth:** 1.34
- **Fifth:** 1.00
- **Sixth:** 0.75
- **Reverse:** 3.99
- **Final Drive Ratio:** 3.27

Gear Ratios - Hydra-Matic™ 8-speed 8L45 Automatic Transmission — RPO M5T (V6 3.6L)

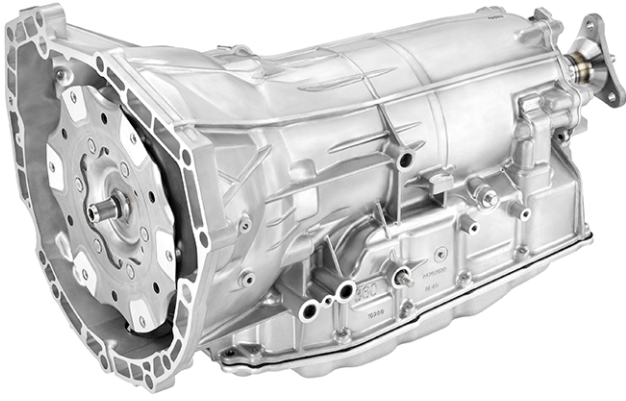

- **First:** 4.62
- **Second:** 3.04
- **Third:** 2.07
- **Fourth:** 1.66
- **Fifth:** 1.26
- **Sixth:** 1.00
- **Seventh:** 0.85
- **Eighth:** 0.66
- **Reverse:** 3.93
- **Final Drive Ratio:** 2.77

Gear Ratios - Tremec TR6060 6-Speed Manual Transmission with Active Rev Match — RPO MM6 (V8 6.2L)

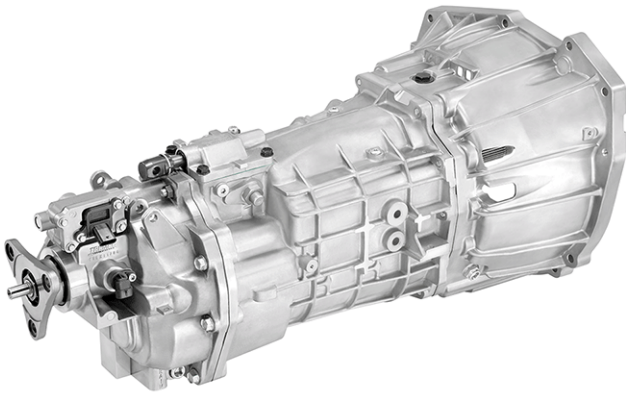

- **First:** 2.66
- **Second:** 1.78
- **Third:** 1.30
- **Fourth:** 1.00
- **Fifth:** 0.74

- **Sixth:** 0.50
- **Reverse:** 2.90
- **Final Drive Ratio:** 3.73

Gear Ratios - Hydra-Matic™ 8-speed 8L90 Automatic Transmission — RPO M5U (V8 6.2L)

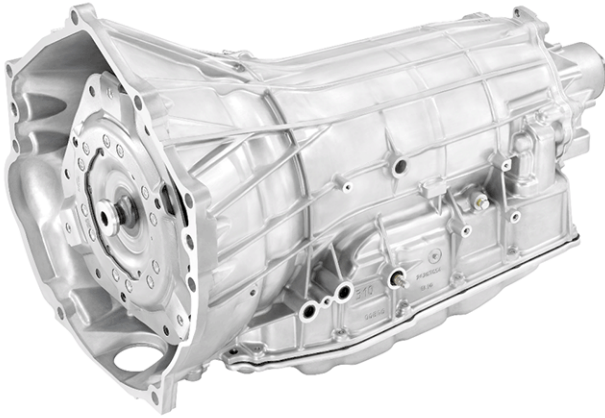

- **First:** 4.56
- **Second:** 2.97
- **Third:** 2.08
- **Fourth:** 1.69
- **Fifth:** 1.27
- **Sixth:** 1.00
- **Seventh:** 0.85
- **Eighth:** 0.65
- **Reverse:** 3.82
- **Final Drive Ratio:** 2.77

Brakes

Brakes



Brembo brakes are standard on SS models and available on LT models with RPO J55 on the front brakes only. The brakes are optimized for the car's mass and performance capability and provide an improved brake feel across the board for all models due to the new ABS system and reduced vehicle mass. The vehicle is equipped with a Bosch ABS 9.0 brake system. The electronic brake control module (EBCM) and the brake pressure modulator valve are serviced separately. The brake pressure modulator valve uses a four circuit configuration to control hydraulic pressure to each wheel independently. Vehicles built with

option RPO FX3 will feature stability enhancement.

The following vehicle performance enhancement systems are provided:

- ABS
- Brake Assist
- Electronic Brake Distribution
- Electronic stability control
- Hill start assist
- Traction control system

Notice: Camaro LT models that are equipped with — RPO JL9 brakes require a revised brake bleed procedure. Refer to SI.

- For the Camaro LT, the brakes include 12.6-inch (320 mm) front rotors with four-piston calipers and 12.4-inch (315 mm) rear rotors with single-piston sliding calipers. The rear brake calipers have an integrated park brake actuator.
- For the Camaro SS, the standard brakes include 13.6-inch (345 mm) front rotors with four-piston fixed calipers and 13.3-inch (338 mm) rear rotors with four piston fixed calipers.

Hill Start Assist

When stopped on a hill, the hill start assist feature prevents the vehicle from rolling before driving off, whether facing uphill or downhill by holding the brake pressure during the transition between when the driver releases the brake pedal and starts to accelerate. The EBCM calculates the brake pressure, which is needed to hold the vehicle on an incline or grade greater than 5% and locks that pressure for up to two seconds by commanding the appropriate solenoid valves **ON and OFF** when the brake pedal is released. The stop lamps will stay illuminated during the hill start assist operation even though the brake pedal is released. This is considered normal operation.

Brake Bleeding

When performing brake system bleeding on any model, you **must** refer to the proper procedure in SI. On LT models equipped with base brakes — RPO JL9, the brake bleed procedure in SI has **additional steps** to enable proper bleeding of that system. Refer to SI and follow the revised procedure.

Electronic Park Brake (EPB) System Description and Operation (RPO J77) — SS Models

Notice: SS Models utilize what is called an Electronic Park Brake (EPB) cable puller system.

The electronic park brake (EPB) apply input force is transferred and evenly distributed, through the park brake cables and the park brake cable equalizer, to the left and right park brake apply levers. The park brake apply levers multiply and transfer the apply input force to the park brake actuators which expand the park brake shoe toward the friction surface of the drum-in-hat portion of the rear brake rotor in order to prevent the rotation of the rear tire and wheel assemblies.

Electronic Park Brake (EPB) Apply (RPO J77) — SS Models

The EPB can be applied any time the vehicle is stopped or in motion. The electric parking brake is applied by momentarily lifting up on the park brake control switch. The red park brake light will momentarily flash while the parking brake is being applied. Once fully applied, the red park brake light will turn **ON**. If the electric parking brake is applied while the vehicle is in motion, a chime will sound, and the message "Release Park Brake Switch" will be displayed.

Electronic Park Brake (EPB) Release (RPO J77) — SS Models

To release the EPB, turn the ignition switch to the **ON or RUN** position, apply and hold the brake pedal, and push down momentarily on the park brake control switch. When the electric parking brake is released the red park brake light turns **OFF**. The EPB can be used to prevent roll back for vehicles with a manual transmission taking off on a hill. In a situation where no roll back is desired, an applied electric parking brake will allow both feet to be used for the clutch and accelerator pedals in preparation for starting the vehicle moving in the intended direction. In this situation, perform the normal clutch and accelerator actions required to begin moving the vehicle. There is no need to push the switch to release the electric parking brake. To disable this feature lift and hold the park brake control switch while the vehicle is in motion, this will keep the electric parking brake applied.

Electric Parking Brake Switch (RPO J71, Motor on Caliper) — LT Models

Notice: LT Models utilize what is called a "Motor on Caliper", which is a small motor attached to the top of the caliper and when the customer presses the button, it applies this motor and thus the rear parking brake. This is integrated in the rear caliper.

Vehicles with the electric parking brake have a switch in the center console, which takes the place of the manual parking brake system, the foot pedal and release handle. In case of insufficient electrical power, the electric parking brake **CANNOT** be applied or released.

Electric Parking Brake Apply (RPO J71, Motor on Caliper) — LT Models

The electric parking brake can be applied any time the vehicle is stopped or in motion. The electric parking brake is applied by momentarily lifting up on the park brake control switch. The red park brake light will momentarily flash while the parking brake is being applied. Once fully applied, the red park brake light will turn **ON**. If the electric parking brake is applied while the vehicle is in motion, a chime will sound, and the message "Release Park Brake Switch" will be displayed.

Electric Parking Brake Release (RPO J71, Motor on Caliper) — LT Models

To release the electric parking brake, turn the ignition switch to the **ON or RUN** position, apply and hold the brake pedal, and push down momentarily on the park brake control switch. When the electric parking brake is released the red park brake light turns **OFF**. The electric parking brake can be used to prevent roll back for vehicles with a manual transmission taking off on a hill. In a situation where no roll back is desired, an applied electric parking brake will allow both feet to be used for the clutch and accelerator pedals in preparation for starting the vehicle moving in the intended direction. In this situation, perform the normal clutch and accelerator actions required to begin moving the vehicle. There is no need to push the switch to release the electric parking brake. To disable this feature lift and hold the park brake control switch while the vehicle is in motion, this will keep the electric parking brake applied.

Suspension

The Camaro features a new, multi-link MacPherson strut front suspension with Camaro-specific geometry. The double-pivot design provides a more precise feeling of control, including more linear and communicative feel from the quick-ratio electric power steering system. At the rear, a new five-link independent suspension yields outstanding wheel control and reduces “squat” during acceleration. The use of lightweight components, including aluminum front suspension links and steel rear suspension links with lightening holes, contributed to a 26 pound (12 kg) reduction in the overall suspension weight.

Magnetic Ride Control is available on the Camaro SS for the first time. Previously limited to the Camaro ZL1, the active suspension reads road and driving conditions 1,000 times per second, and automatically adjusts the damper settings to optimize ride comfort and control.

Steering

All models will incorporate quick-ratio Electric Power Steering (EPS). Each trim level will have a unique and customized steering effort and feel. Two steering gears will be offered, both with variable ratio. The SS models will offer an overall faster ratio with 2.5 turns lock-to-lock.

Tires / Wheels

Notice: If the Customer has a flat tire with run-flat tires, the DIC will display a message of zero tire pressure.

Goodyear tires are used on all models as follows:

- The Camaro LT features standard 18-inch wheels matched with Goodyear Eagle® Sport AS (all-season) 245mm tires. An inflator kit comes standard with all 18-inch tires.
- The Camaro LT available 20-inch wheels matched with Goodyear Eagle® F1 Asymmetric AS (all-season) EMT (extended mobility technology) 245mm run-flat tires. This 20-inch tire blends the attributes of the 18-inch tire with all season capability with the steering response of the 20-inch summer tire. The 20-inch tires are run-flat with a driving distance of 50 miles (80 km).
- The Camaro SS features standard 20-inch aluminum wheels with Goodyear Eagle F1 Asymmetric 2 EMT (extended mobility technology) performance tire with a staggered fitment of 245 mm front and 275 mm rear width. All four wheels are 12.7 mm wider than previous fifth-generation SS wheels. The 20-inch tires are run-flat with a driving distance of 50 miles (80 km). SS tires are **summer-only tires**.

Driver Mode Control — Tour, Sport, Snow/Ice and Track Settings

Driver Mode Control

Driver Mode Control adds a sportier feel, provides a more comfortable ride, or assists in different weather conditions or terrain. This system simultaneously changes the software calibration of various sub-systems. Depending on the option package, available features, and mode selected, the suspension, steering, and powertrain will change calibrations to achieve the desired mode characteristics. If the vehicle is equipped with Magnetic Ride Control, selecting the various Driver Modes adjusts the ride of the vehicle to enhance the ride performance for the road conditions and the selected mode.

While in the Sport and/or Track Modes, the vehicle monitors driving behavior and automatically enables Performance Shift Features when spirited driving is detected. These features maintain lower transmission gears to increase available engine braking and improve acceleration response. The vehicle will exit these features and return to normal operation after a short period when no spirited driving is detected.



- **Driver Mode Control Switch:** The Driver Mode Control has three or four modes: Tour, Sport, Snow/Ice, and Track. The Track Mode is for V8 models only. Press the **UP** or **DOWN** arrow on the MODE control switch on the center console to make a mode selection. Pressing the switch will display a graphic of all available ride modes and change to the next mode. The Tour and Sport Modes will feel similar on a smooth road. Select a new setting whenever driving conditions change.

- **Tour Mode:** Use for normal city and highway driving to provide a smooth, soft ride. When selected, the Tour Mode indicator will display in the Driver Information Center (DIC).
- **Sport Mode:** Use when road conditions or personal preference demand a more controlled response. When selected, the Sport Mode indicator will display in the DIC. When in Sport Mode, the vehicle will shift automatically but hold a lower gear longer than it would in the normal driving mode based on braking, throttle input, and vehicle lateral acceleration. The steering will change to provide more precise control. If the vehicle has Magnetic Ride Control the suspension will change to provide better cornering performance. If the vehicle is equipped with Active Exhaust, the exhaust valves will open earlier and more often. Competitive Driving Mode can be accessed through this mode by pressing the button with the Traction Control/StabiliTrak® icon twice.
- **Snow/Ice Mode:** Use when more traction is needed during slippery conditions. The vehicle will upshift normally when the vehicle is moving. The acceleration will adjust to help provide a smoother launch. The transmission will also shift differently to assist in maintaining traction. When selected, the Snow/Ice Mode indicator will display in the DIC. This feature is **not** intended for use when the vehicle is stuck in sand, mud, ice, snow, or gravel.
- **Track Mode (SS Only):** Use when maximum vehicle handling is desired. When selected, the Track Mode indicator will display in the DIC. When in Track Mode, the automatic transmission and steering will function similar to Sport Mode. The accelerator pedal is adjusted to give maximum control during the highest level of spirited driving. The Magnetic Ride Control will be set to the optimum level for vehicle responsiveness. If the vehicle is equipped with Active Exhaust, the exhaust valves will open. Competitive Driving Mode can be accessed through this mode by pressing the button with the Traction Control/StabiliTrak® icon.

Driver Mode Control — Competitive Driving Mode Settings

- **Competitive Driving Mode (SS Only):** Competitive Driving Mode and Launch Control are systems designed to allow increased performance while accelerating and/or cornering. This is accomplished by regulating and optimizing the engine, brakes, and suspension performance. These modes are for use at a closed course race track and **are not intended for use on public roads**. They will not compensate for a driver's inexperience or lack of familiarity with the race track. Drivers who prefer to allow the system to have more control of the engine, brakes, and suspension are advised to turn the normal TCS and StabiliTrak® systems ON.
- **Competitive Driving Mode (SS Only):** Competitive Driving Mode allows full engine power while the StabiliTrak system helps maintain directional control of the vehicle by selective brake application. In this mode, TCS is OFF and Launch Control is available. Adjust your driving style to account for the available engine power.

Notice: This feature is intended for use during closed course race events where consistent zero to sixty and quarter mile times are desirable.
- **Launch Control (SS Only):** The Launch Control feature is available, within Competitive Driving Mode, to allow the driver to achieve high levels of vehicle acceleration in a straight line. Launch Control is a form of traction control that manages tire spin while launching the vehicle. Launch Control is only available when the following criteria are met:
 - Competitive Driving Mode is selected.
 - The vehicle is not moving.
 - The steering wheel is pointing straight.
- **Launch Control - Manual Transmissions (SS Only):** The clutch is pressed and the vehicle is in **1** (First) gear. The accelerator pedal is rapidly applied to wide open throttle. The Launch Control feature will initially limit engine speed as the driver rapidly applies the accelerator pedal to wide open throttle. Allow the engine rpm to stabilize. A smooth, quick release of the clutch, while maintaining the fully pressed accelerator pedal, will manage wheel slip.
- **Launch Control - Automatic Transmissions (SS Only):** The brake pedal must be firmly pressed to the floor, equivalent to a panic brake event. The accelerator pedal is rapidly applied to wide open throttle. If the vehicle rolls due to wide open throttle, release the throttle, press the brake pedal more firmly, and re-apply the accelerator to wide open throttle. After the vehicle is launched, the system continues in Competitive Driving Mode.

Accessories and Performance Parts Portfolio

Refer to the Accessory Information Guide in Global Connect for a complete list of available accessories.

Driver Assistance Systems

Rear Vision Camera

Notice: Periodically clean the rear vision camera (RVC) lens, which is located above the rear license plate with clean water and a soft cloth.

Rear vision camera (RVC) is standard on all models. When the vehicle is shifted into **R** (Reverse), an image of the area behind the vehicle appears in the infotainment screen. The previous screen displays when the vehicle is shifted out of **R** after a short delay.

To see the previous screen sooner, perform one of the following:

- Press a button on the infotainment system.
- Shift into **P** (Park).

To turn the RVC Guidance Lines or Rear Park Assist Symbols **ON** or **OFF**, go to Rear Camera in the Settings menu.

Rear Park Assist

Available on 2LT and standard on the 2SS is Rear Park Assist. When the vehicle is in **R** (Reverse), detected objects are indicated by audible beeps. The interval between beeps becomes shorter as the vehicle gets closer to an object. When the distance is less than 16 in. (40 cm), the beeps are continuous for 5 seconds. The system only operates at speeds of less than 5 mph (8 km/h).

Lane Change Alert (LCA)

If equipped, the LCA system is a lane-changing aid that assists drivers with avoiding lane change crashes that occur with moving vehicles in the side blind zone (or spot) areas or with vehicles rapidly approaching these areas from behind. The LCA warning display will illuminate in the corresponding outside side mirror and will flash if the turn signal is **ON**. The Side Blind Zone Alert (SBZA) system is included as part of the LCA system. The SBZA system is a lane-changing aid that assists drivers with avoiding crashes that occur with moving vehicles in the side blind zone (or spot) areas. When the vehicle is in a forward gear, the left or right side mirror display will illuminate if a moving vehicle is detected in that blind zone. If the turn signal is activated and a vehicle is also detected on the same side, the display will flash as an extra warning not to change lanes.

Rear Cross Traffic Alert (RCTA) System

Standard on the 2SS and available on the 2LT, the RCTA system uses a triangle with an arrow displayed on the RVC screen to warn of traffic behind your vehicle that may cross your vehicle's path while in **R** (Reverse). In addition, beeps will sound.

Wireless Inductive Smartphone Charging System

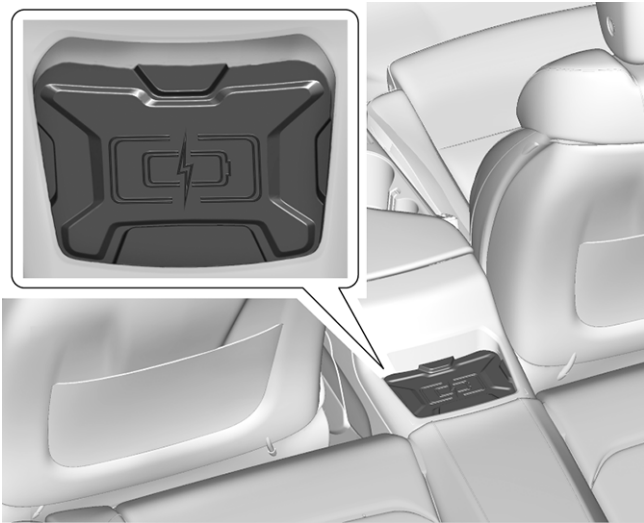

Wireless charging is standard on the 2SS and available on the 2LT. If equipped, the vehicle has a wireless charging pad at the back of the floor console.

The wireless inductive charging system for smartphones is Compatible with Powermat and other in-phone wireless charging technologies, this convenient feature eliminates the need for charging cords. An increasing number of smartphones have wireless charging either embedded or as an option. To charge a compatible device using the wireless inductive charging system, the device is simply placed on the rubberized pad.

The system is capable of charging the batteries of many aftermarket devices, including cell phones, PDAs, pagers, MP3 players, etc.

A compatible device is one that is compliant with the Power Matters Alliance (PMA) or Wireless Power Consortium's (WPC) Qi Standard, meaning that it is equipped with a PMA or Qi wireless charge "**receiver**" that will work with the charge "**transmitter**" installed in the vehicle. A device may use built-in charging circuitry or an adapter (an external plug-in device which contains the charging circuitry).

When the Interruptible Retained Accessory Power (RAP) relay is closed (when the vehicle ignition is in **Run** or **Accessory** position), the system is able to detect the device, establish communications with the device to confirm it is a compatible device, and then deliver charging power to the device via the wireless interface.

If a non-compatible device or metallic foreign object is detected, the system will not transfer power. The charger monitors its internal temperature and will shut down if the charger temperature exceeds 185°F (85°C).

The BCM will detect that the device battery is charging and send a serial data message to the infotainment touch screen, which will indicate a device is currently charging. When the battery charging symbol is toggling **ON** and **OFF**, it indicates a thermal limit has been reached and the device will not charge. Charging may also be interrupted while driving over rough conditions.

- ⇒ If the device does not charge or stops charging, remove it from the pad for approximately 3–5 seconds before returning the mobile device to the pad to continue charging.

To check for phone or other device compatibility, Go to www.gmttotalconnect.com. or in Canada, Go to www.gmttotalconnect.ca (English) or www.connexiontotalegm.ca (French).

Air Bags

The sixth-generation Camaro will have eight air bags compared to the fifth-generation having six air bags. The two additional air bags are driver and front

passenger knee air bags.

Chevrolet MyLink™ with Phone Integration Technology

Infotainment Options

The Camaro offers three different infotainment options. Availability varies based on the model.

- **Radio — RPO IOB:** Radio infotainment system - Midlevel HMI, midlevel connectivity, No Apps Infotainment, 7-inch (178 mm) color touchscreen ICS display. Bluetooth® provided via OnStar®. Bring your own media.
- **Radio — RPO IO5:** Radio infotainment system - Uplevel HMI, enhanced connectivity, including OnStar® Directions. Base connectivity features plus 8-inch (203 mm) color touchscreen ICS display.
- **Radio — RPO IO6:** Radio infotainment system - Embedded navigation radio system, uplevel HMI. Enhanced connectivity features plus 8-inch (203 mm) color touchscreen ICS display.



Chevrolet MyLink™ — RPOs IO5 and IO6

The 2016 Camaro has Chevrolet's MyLink infotainment system gives owners a smart and simple way to access Apple CarPlay and Android Auto (Android Auto was a mid-model year introduction – see bulletin 16-NA-042 for more details). Each of these system builds off of the features smartphone users rely on most, with many controlled via voice commands using a button on the steering wheel. That helps drivers spend more time with their eyes on the road and hands on the wheel. New volume control and other physical buttons reduce complexity and enhance the system's intuitiveness.

- Apple CarPlay™ puts iPhone® features on the vehicle's display in a smart, simple manner, allowing drivers to make calls, send and receive messages and listen to music right from the touchscreen or by voice via Siri®. Supported apps for Apple CarPlay™ include Phone, Messages, Maps, Music and compatible third-party apps. For a full list of supported apps visit: www.Apple.com/ios/carplay
- Android Auto™ is built around Google Maps™, Google Now™ and the ability to talk to Google®, as well as a growing audio and messaging app ecosystem that includes WhatsApp, Skype, Google Play Music, Spotify, and podcast players. For a full list of supported apps visit: www.Android.com/auto

Using either application is simple. A "Projection" icon on the MyLink™ screen is visible when a phone is **not** connected and changes to indicate Apple CarPlay™ or Android Auto™ when a compatible phone is connected via a USB. Apple CarPlay™ requires an iPhone® 5 or later and Android Auto™ requires a phone running the Android Lollipop 5.0 operating system or above.

Compatible apps need to be downloaded to a phone before using.

OnStar® 4G LTE with Built-In Wi-Fi Hotspot

Notice: To retrieve the SSID and password for the Wi-Fi hotspot, press the OnStar® Voice Command button on the rearview mirror, wait for the prompt, and then say "Wi-Fi settings." The information will be displayed on the screen. For assistance, press the blue OnStar® button or call 1-888-4-ONSTAR (1-888-466-7827).

The OnStar® built-in Wi-Fi hotspot supports up to seven mobile devices so passengers can connect to the content they want. OnStar® with 4G LTE offers a stronger, more reliable signal; and it's built-in, so it's easy to use. Plus, it's connected to your vehicle battery, so you're always fully charged for the adventure ahead.

The powerful OnStar® connection also enables improved access to existing OnStar® safety and security services, including the ability to transmit voice and data simultaneously. That means OnStar® advisors can run a diagnostic check without ever leaving the call, making customer interactions quicker and more seamless. It's the most comprehensive in-vehicle safety and connectivity system available.

Towing / Transport / Recovery

Caution: Incorrectly towing a disabled vehicle may cause damage. The damage would not be covered by the vehicle warranty. **DO NOT lash or hook to suspension components. Use the proper straps around ALL of the tires to secure the vehicle.**

Tow Hook / Access Point and Cover



The tow hook (shown installed) access **point** on the Camaro was uniquely packaged in the front grille to keep a clean, bold, front end appearance. The LT and the GM accessory grille do not have a tow hook access **cover**. To access the tow hook access **point** on the SS, a small **cover** will need to be removed.

Towing and Recovery of a Disabled Vehicle

Transport the vehicle on a flatbed car carrier only. A wheel lift tow truck could damage the vehicle. Consult your dealer or a professional towing service if the disabled vehicle must be towed.

- **DO NOT** hook, pull or secure the vehicle using any of the under body or suspension components.
 - Recover/transport the vehicle using a flatbed car carrier only.
 - Once on a flatbed, secure the vehicle to the bed using a nylon strap type harness over **all** four tires.
1. If it is necessary to use the flat bed mounted winch to recover the vehicle, locate the recover tow eye secured in the rear compartment storage area.
 2. Carefully open the cover in the front fascia. V6 and V8 models differ. Refer to the Owner Manual.
 3. Install the tow eye into the socket by turning it clockwise until it stops.
 4. Attach the recovery cable to the installed tow eye and load the vehicle onto the flatbed.

Trailer Towing

The vehicle was neither designed nor intended to tow a trailer.

Recreational Vehicle Towing

The vehicle was neither designed nor intended to be towed with any of its wheels **on** the ground.

Training Courses — United States and Canada

Notice: Other Global Regions should refer to their local GM Training sources as applicable.

The majority of the systems found on this vehicle are taught in GM's core curriculum from a conceptual theory and operation perspective. The North American technical training core curriculum structure is system based.

To access **all** of the available training courses visit the following website:

- In the United States, Go to > www.centerlearning.com
- In Canada, Go to > GM GlobalConnect and select "Centre of Learning"

Training Course Name or System – Course Number and Description

Course Name or System	Course Number and Description
New Model Launch 2016 Chevrolet Camaro New Model Launch	#10316.39W 2016 Chevrolet Camaro New Model Launch (WBT) (U.S. and Canada)

ENGINE-GAS, 6 CYL, 3.6L, V6, DI, DOHC, VVT, ALUM, GEN 2	#16440.20D Engines: New and Updates for RPOs LF4 LGXLGW L3A LV7 LE2 LWN
ENGINE-GAS, 8 CYL, 6.2L, DI, AFM, VVT, HO,ALUM, GMNA	#16440.18D Engines: New and Updates for RPOs LT1,LV3, LUZ, LKW, LF3, L83, L86
TRANSMISSION-AUTO 8 SPD, 8L45	#17440.16D Transmissions: New and Updates for 8L45and Aisin AF50
TRANSMISSION-AUTO 8 SPD, 8L90	#17440.15 Transmissions: New and Updates for 8L90Automatic Transmission RPO M5U
TRANSMISSION-MAN 6 SPD, TREMEC, 85MM,2.66 1ST, 0.50 6TH, O/D	#17043.45V GM TR6060 Tremec 6-Speed TransmissionOverhaul
TRANSMISSION-MAN 6 SPD, 81MM, 4.45 1ST,2.83 2ND, 1.98 3RD, 1.40 4TH, 1.00 5TH, 0.76	

Special Tools

The following new tools were released for the 2016 Camaro:

Tool #	Description
CH-47976-513	AFIT Adapter G2C, STOP/START with SENT Fuel Sensor
CH-47976-507	AFIT Adapter, SENT Fuel Pressure
CH-47976-511	Cable, G5, Active Fuel Injection Tester (AFIT) SIDI
DT-50905-3	Adapter, Clutch Air Travel Fixture Used with DT-50905-1 Base
DT-51087	Installer, Case Extension Bearing
DT-51088	Installer, Turbine Shaft Seal
DT-51089	Installer, Clutch Housing Bearing
DT-51196	Installer, Stator Shaft Seal
DT-51791	Removers, Front Cover Slide Hammer Adapters (Set of 2)
EN-42385-70	Head Bolt Thread Repair Torque Plate
EN-44226-5	Crankshaft Button
EN-46335-A	Valve Spring Compressor - Head On
EN-51333	Timing Chain Retainer
EN-51760	Flywheel Holder
EN-51766	Crankshaft Rear Oil Seal Installation Tool

EN-51767	Stretchy Belt Tool Installer
DT-50806	Bushing Replacer
DT-51075	Remover Legs, 4th Speed Driven Gear
DT-51076	Installer, Bearing and Gear
DT-51077	Shift Rail Seal Installer (Installs Below Flush)
DT-51263	Pinion Flange Installer Adapter (Linamar RDM - Camaro & CT6)
DT-51750	Pinion Seal Installer (Linamar RDM - Camaro & CT6)
EN-28540-A (or J-28540-A)	Seal Installer, Output Shaft (Linamar RDM - Camaro & CT6)

Version Information

Version	2
Modified	Oct. 28, 2016 – Updated Chevrolet MyLink™ information and Training Courses.

Trademark Footnotes

Android™ is a Trademark of Google Inc.

Android Auto™ is a Trademark of Google Inc.

Apple® is a Registered Trademark of Apple Inc.

Apple CarPlay™ is a Trademark of Apple Inc.

The Bluetooth® Word Mark and Logos are Registered Trademarks Owned by Bluetooth SIG, Inc.

dexos® is a Registered Trademark of General Motors LLC

dexos1® Icons are Registered Trademarks of General Motors LLC

Chevrolet MyLink™ is a Trademark of General Motors LLC

Goodyear Eagle® is a Registered Trademark of The Goodyear Tire & Rubber Company

Google® is a Registered Trademark of Google Inc.

Hydra-Matic™ is a Trademark of General Motors LLC

iPhone® is a Registered Trademark of Apple Inc.

OnStar® is a Registered Trademark of OnStar LLC

Siri® is a registered Trademark of Apple Inc.

GM bulletins are intended for use by professional technicians, NOT a "do-it-yourselfer". They are written to inform these technicians of conditions that may occur on some vehicles, or to provide information that could assist in the proper service of a vehicle. Properly trained technicians have the equipment, tools, safety instructions, and know-how to do a job properly and safely. If a condition is described, DO NOT assume that the bulletin applies to your vehicle, or that your vehicle will have that condition. See your GM dealer for information on whether your vehicle may benefit from the information.



WE SUPPORT VOLUNTARY TECHNICIAN CERTIFICATION