



Service Bulletin

PRELIMINARY INFORMATION

Subject: Creak or Squeak When Opening Rear Compartment Lid

Models: 2014-2015 Chevrolet Caprice PPV
2014-2015 Chevrolet SS

Condition/Concern

Some customers may comment that during the opening of the rear compartment lid, there is a creak or squeak noise heard.

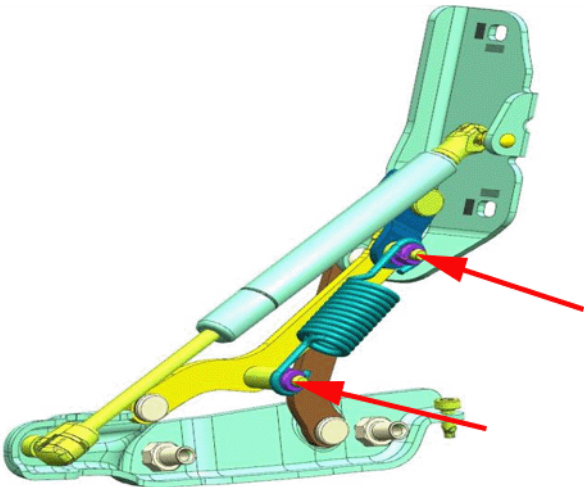

This may be caused by interference between the rear compartment lid hinge spring bushings and the rear compartment lid hinge spring pins.

Recommendation/Instructions

Use the following steps to lubricate the left and right hinge spring bushings.

1. Attach the extension tube onto a can of Super Lube® Synthetic Multipurpose Lubricant 11 oz. Aerosol.

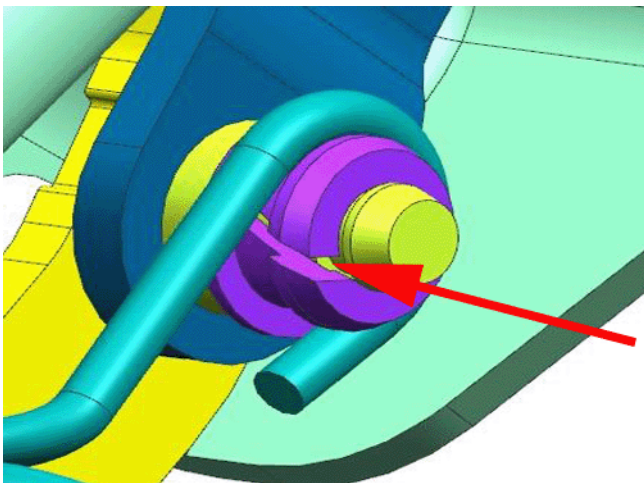

2. Spray the lubricant into both of the bushing grooves as illustrated above.
Note: There are two hinge spring bushings per spring.
3. Repeat step 2 on the opposite side of vehicle.
Important: Failure to properly lubricate the bushings may lead to noisy operation.
4. Wipe off any lubricant overspray from the repair area using a shop towel.
5. Open and close the rear compartment lid to verify the noise is gone.

Parts Information

Part Number	Description
12346241 (in Canada, 10953474)	Super Lube® Synthetic Multipurpose Lubricant 11 oz. Aerosol

Warranty Information

For vehicles repaired under the Bumper-to-Bumper coverage (Canada Base Warranty coverage), use the following labor operation. Reference the Applicable Warranties section of Investigate Vehicle History (IVH) for coverage information.

Labor Operation	Description	Labor Time
2080448*	Lube Rear Compartment Lid Hinge Spring Bushings	0.2 hr
*This is a unique Labor Operation for Bulletin use only. It will not be published in the Labor Time Guide.		

GM bulletins are intended for use by professional technicians, NOT a "do-it-yourselfer". They are written to inform these technicians of conditions that may occur on some vehicles, or to provide information that could assist in the proper service of a vehicle. Properly trained technicians have the equipment, tools, safety instructions, and know-how to do a job properly and safely. If a condition is described, DO NOT assume that the bulletin applies to your vehicle, or that your vehicle will have that condition. See your GM dealer for information on whether your vehicle may benefit from the information.



WE SUPPORT VOLUNTARY TECHNICIAN CERTIFICATION