



# Service Bulletin

## SERVICE UPDATE

**SUBJECT:** Service Update for Inventory and Customer Vehicles  
Body Harness Contact with Park Brake Bracket  
Expires with Base Warranty

**MODELS:** 2014-2015 Chevrolet Silverado  
2014-2015 GMC Sierra

This service update includes vehicles in dealer inventory and customer vehicles that return to the dealership for any reason. This bulletin will expire at the end of the involved vehicle's New Vehicle Limited Warranty period.

### PURPOSE

This bulletin provides a service procedure to tie strap the “Main” and “BCM” branches of the body harness (near the front of dash pass-through inside the vehicle) together to prevent them from coming in contact with park brake bracket on **certain** 2014 and 2015 model year Chevrolet Silverado and GMC Sierra vehicles. These vehicles may have exposed body harness wires in close proximity to the parking brake bracket at the front dash pass-through inside the vehicle. The exposed body harness wires can rub against or be pinched by the brake bracket. While there is no evidence of this happening in customer vehicles, if the wires were to be sufficiently damaged from rubbing against or being pinched by the brake bracket, certain electrical systems could be affected. For example, sufficient damage to the wires could result in the loss of various exterior lights, wipers, the driver’s airbag telltale light, throttle control, defog controls, or trailer brake controls. In addition, while there is no evidence of any stalls resulting from this condition, it is possible that if the run/crank wire was sufficiently damaged, it could result in an engine stall. Depending on which circuit is damaged, a telltale or DIC message may be displayed alerting the customer that an issue exists.

**This service procedure should be completed as soon as possible on involved vehicles currently in dealer inventory and customer vehicles that return to the dealer for any type of service during the New Vehicle Limited Warranty coverage period.**

### VEHICLES INVOLVED

All involved vehicles are identified by VIN in the Global Warranty Management System – Investigate Vehicle History Application. Dealership technicians should always check this site to confirm vehicle involvement prior to beginning any required inspections and/or repairs. It is important to routinely use this tool to verify eligibility because not all similar vehicles may be involved regardless of description or option content.

Additionally, a list of involved vehicles currently in dealer inventory is available on the “Service Update Bulletin Information” link under the “Service” tab in GM GlobalConnect (US) or attached

to the GlobalConnect message (Canada) used to release this bulletin. Customer vehicles that return for service, for any reason, and are still covered under the vehicle's base warranty should also be checked for vehicle eligibility.

### PART INFORMATION

No parts are required for this repair.

### SERVICE PROCEDURE

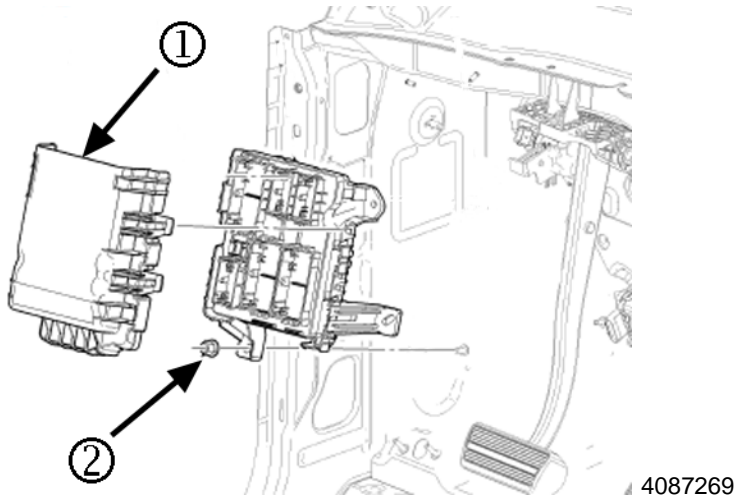

1. Remove the body wiring harness junction block cover (1) located on firewall, right of the park brake assembly. Pull the tabs on either side of the cover to remove.
2. Remove the nut (2) from the junction block bracket.



3. Position the junction block away from the park brake.



4087276

4. Locate the fork (1) of the BCM break-out harness from the body harness.
5. Secure the break-out harness away from the park brake bracket by adding the tie strap (2), approximately 25 mm (1.0 in) above the fork.
6. Verify the increased clearance between the harness and the park brake bracket.

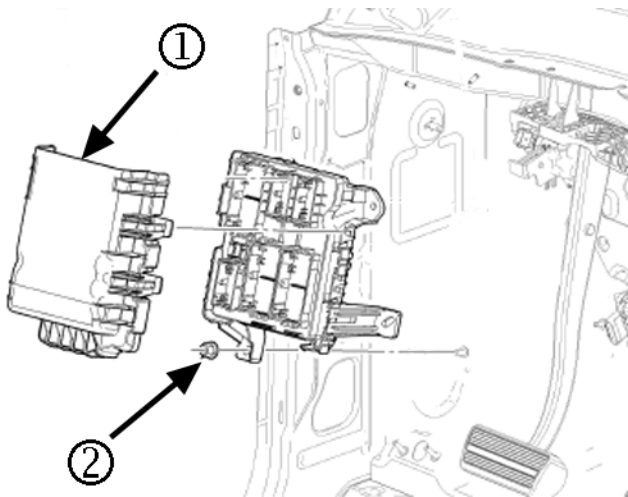

4087269

7. Reinstall the junction block and install the nut (2). Tighten the nut to 9 N\*m (80 lb in).
8. Reinstall the body wiring harness junction block cover (1).

### WARRANTY TRANSACTION INFORMATION

Submit a transaction using the table below. All transactions should be submitted as a ZFAT transaction type, unless noted otherwise.

Labor Code	Description	Labor Time
9101319	Reposition and Tie Strap Body Harness Wiring	0.5

**DEALER PROGRAM RESPONSIBILITY**

Whenever a vehicle subject to this service update enters your vehicle inventory, or is in your facility for service in the future, and the vehicle is still covered under the New Vehicle Limited Warranty, you must take the steps necessary to be sure the service update correction has been made before selling or releasing the vehicle.



GM CUSTOMER CARE AND AFTERSALES  
DCS3562  
URGENT - DISTRIBUTE IMMEDIATELY

Date: February 24, 2015

Subject: 14725 – Service Update Bulletin  
Body Harness Contact with Park Brake Bracket

Models: 2014-2015 Chevrolet Silverado  
2014-2015 GMC Sierra

To: All Chevrolet and GMC Dealers

Attention: General Manager, Service Advisor, Service Manager, Parts and  
Service Director, Parts Manager, New Vehicle Sales Manager,  
and Warranty Administrator

General Motors is releasing Service Update Bulletin 14725 today. The total number of U.S. vehicles involved is approximately 14032. Please see the attached bulletin for details.

**Global Warranty Management (GWM)**

The “Investigate Vehicle History” (IVH) screen will be updated February 26, 2015. A list of involved vehicles in dealer inventory is attached to this message.

END OF MESSAGE  
GM CUSTOMER CARE AND AFTERSALES