

# Tire Pressure Warning System Initialization

**Service Category** General

**Section** Pre-Delivery Service

**Market** USA

Lexus Supports  
ASE Certification 

## Applicability

YEAR(S)	MODEL(S)	ADDITIONAL INFORMATION
2016	IS200T, IS300, IS350	

## Introduction

2016 model year IS 200t/300/350 vehicles are equipped with a direct-type Tire Pressure Warning System (TPWS). Each tire (except the spare tire) has a tire pressure warning valve/transmitter and the measured tire pressure data is sent to the tire pressure warning antenna by electric wave and then sent to the receiver.

During Pre-Delivery Service (PDS), the TPWS must be initialized according to the procedure in this bulletin.

## Warranty Information

OP CODE	DESCRIPTION	TIME	OFP	T1	T2
N/A	Not Applicable to Warranty	–	–	–	–

## Required Tools & Equipment

REQUIRED EQUIPMENT	SUPPLIER	PART NUMBER	QTY
Techstream 2.0*	ADE	TS2UNIT	1
Techstream Lite		TSLITEPDLR01	

\* Essential SST.

### NOTE

- Only ONE of the Techstream units listed above is required.
- Software version 10.20.030 or later is required.
- Additional Techstream units may be ordered by calling Approved Dealer Equipment (ADE) at 1-800-368-6787.

# Tire Pressure Warning System Initialization

## Initialization Procedure

1. Adjust all tires (except the spare tire) to the standard tire inflation pressure, as indicated on the Tire and Loading information label located inside the vehicle.

**NOTE**

- To adjust tire pressure correctly when outside temperature is significantly colder than shop temperature, perform a Health Check using Techstream and select the “Compensation Tire Pressure” checkbox. Compensation pressures will be displayed on the health check results screen.
- Adjust the tire pressure when the tires are cold.

**Figure 1.**

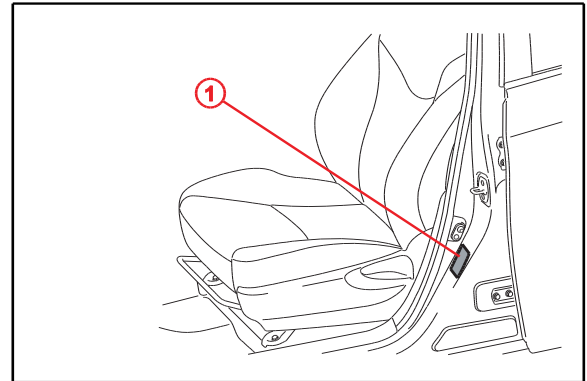

<b>1</b>	<b>Tire and Loading Information Label</b>
----------	---

2. Cycle the ignition switch to the “IG-ON” position and press and hold the Tire Pressure Warning Reset Switch for at least 3 seconds so that the Tire Pressure Warning light blinks 3 times.

**Figure 2.**

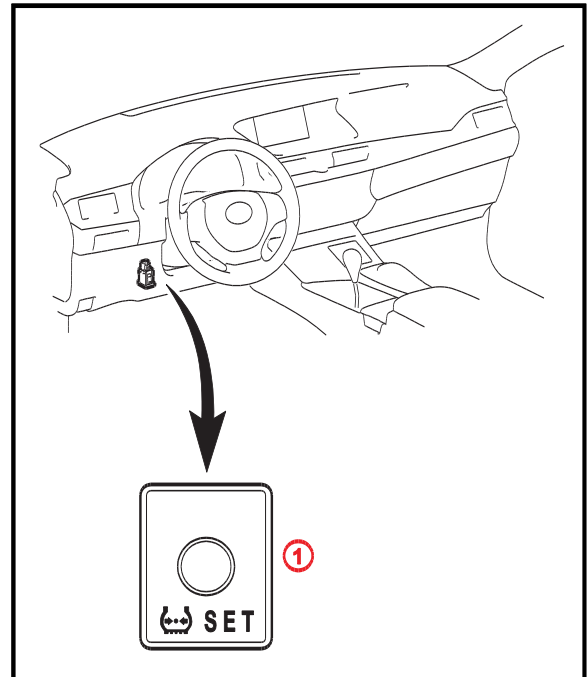

<b>1</b>	<b>Tire Pressure Warning Reset Switch</b>
----------	---

## Tire Pressure Warning System Initialization

---

### Initialization Procedure (Continued)

3. Cycle the ignition switch to the "OFF" position and then to the "IG-ON" position.

**NOTE**

It is necessary for the ignition to be in the "IG-ON" mode AT LEAST 5 minutes for the initialization to complete correctly.

4. Check the tire pressure values of all the tires using Techstream.

**NOTE**

- It can take 2 – 3 minutes for the tire pressure values to be displayed on the Techstream Data List.
- If the tire pressure values CANNOT be displayed on the Techstream screen, the initialization is NOT completed. Repeat steps 2 – 4.