

Initial Calibration of Compass During PDS

Service Category General

Section Pre-Delivery Service

Market USA

Lexus Supports ASE Certification

Applicability

YEAR(S)	MODEL(S)	ADDITIONAL INFORMATION
2016	ES300H, ES350	

Introduction

2016 model year ES 350 and ES 300h vehicles are equipped with a compass in the rear view mirror. Use the following procedure to complete initial calibration of the compass during Pre-Delivery Service (PDS).

Warranty Information

OP CODE	DESCRIPTION	TIME	OFF	T1	T2
N/A	Not Applicable to Warranty	-	-	-	-

Compass Calibration Procedure

1. Cycle the ignition switch to the "IG-ON" position and push and hold the mirror switch until the zone number appears on the compass display.

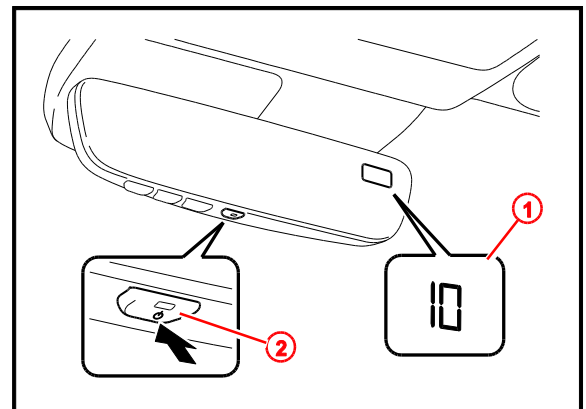

1	Compass Display
2	Mirror Switch

Initial Calibration of Compass During PDS

Compass Calibration Procedure (Continued)

2. Push the mirror switch to select the number of the zone where the vehicle is located.

NOTE

When the compass is NOT in calibration mode, pushing the Mirror Switch will toggle the compass display ON and OFF.

See the map for zone reference.

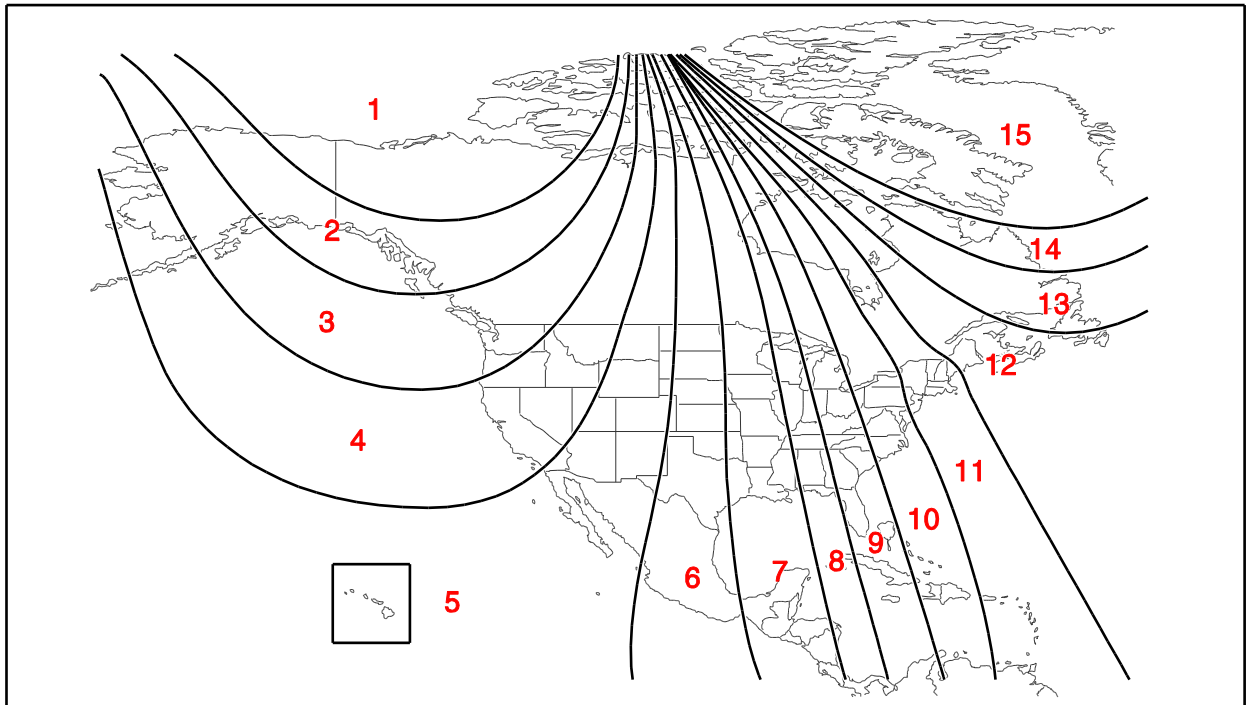

3. Start the engine (or hybrid system) and push and hold the mirror switch for about 12 seconds until "C" appears on the compass display.

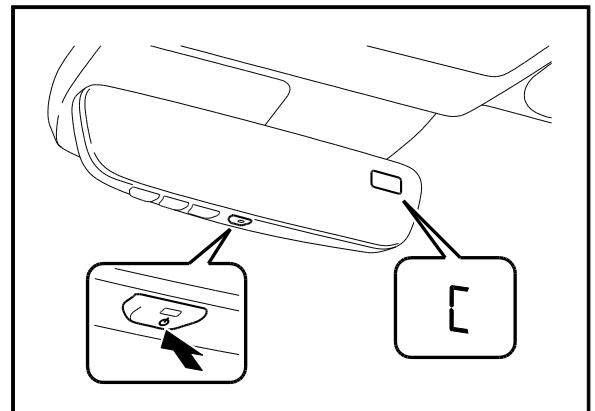

Initial Calibration of Compass During PDS

Compass Calibration Procedure (Continued)

4. Drive the vehicle slowly at 5 mph (8 km/h), or less, in a circle until the direction is displayed. If there is NOT enough space to drive in a circle, drive around the block until the direction is displayed.

Once the direction is displayed, the calibration is complete.

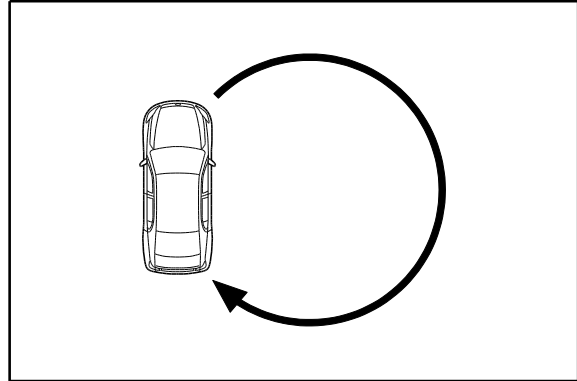

NOTE

- Do NOT perform calibration of the compass in a place where the Earth's magnetic field is subject to interference by artificial magnetic fields (underground parking, under a steel tower, between buildings, roof parking, near a railroad crossing, near a large vehicle, etc.)
- During calibration, do NOT operate electric systems (moon roof, power windows, etc.) as they may interfere with the calibration.