

Pre-release 5  
April 02, 2015

Material: added images; Step 5 & 6: grind flush prepare & protect; Added appendix "A"

## POSITIVE BOOSTER BLOCK PROTECTION Prevost vehicles

### DESCRIPTION







On the vehicles affected by this bulletin, replace the existing positive booster block and cable terminal by a protected assembly.



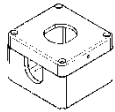





### MODEL YEAR(S) AND VEHICLES INVOLVED

<i>NOTICE TO SERVICE CENTERS</i>	
<i>Verify vehicle eligibility by checking warranty bulletin status with <b>SAP</b> or via <b>ONLINE WARRANTY SYSTEM</b> available on Service / Warranty tab of Prevost website.</i>	
Model	VIN
X3-45 coaches Model Year : 2008 - 2009	The following <b>GLI / Bolt Bus</b> Fleet vehicles: 2PCG334908 <u>C729426</u> up to 2PCG334959 <u>C729794</u> incl.
X3-45 coaches Model Year : 2008 - 2010	The following <b>PWT Diversified</b> Fleet vehicles: 2PCG334937 <u>1028938</u> up to 2PCG33490 <u>AC729948</u> incl.
<p><b>This bulletin does not necessarily apply to all the above-mentioned vehicles, some vehicles may have been modified before delivery. The owners of the vehicles affected by this bulletin will be advised by a letter indicating the Vehicle Identification Number (VIN) of each vehicle concerned.</b></p>	

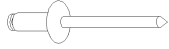

### MATERIAL NEEDED

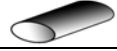
Order SP15-313 which includes the following parts:

Part No.	Identification	Description	Qty
382441	① 	Box, Protective 120x122x91	1
5001305	② 	Screw, Machine Round Head PH, SS 8-32 X 3/4	1
5001137	③ 	Washer, Flat SS .203 x .438 x .05	1
500678	④ 	Nut, Well 8-32 x .450	1
382444	⑤ 	Washer, Foam Sealing	1
500270	⑥ 	Washer, Flat SS .406 x 1 x .063	1
504671	⑦ 	Grommet 1 x .125 x .437 x 1.312	1

5001936		Nut, Hex Nylon Insert, SS 3/8-16	1
560895		RING TERMINAL .375 / 2/0 (CLOSED END)	1
561856		BOOSTER BLOCK, REMOTE / RED	1
5001935		WSH FL SS 10.5 X 18 X 1.6 MM	1
381210		SEPARATOR / FIBERGLASS RED	1
504339		RIVET POP DOME OPEN END 3/16x3/8 SS	4
561755		SHRINK TUBING / 0.750" TO .375" / RED	50mm
563156		SHRINK TUBING / 0.700" TO 0.175" BLACK	60mm
062682		DECAL / "BOOSTER BLOCK" ENG & FRENCH	1
063824		BRACKET, BOOSTER BLOCK	1

Other parts that may be required:

Part No.		Description	Qty
684213		COLOR GUARD	90 ml
680532		SEALANT SIKA #221 / GREY / 310ml CARTRIDGE	310ml
682175		3M 08883 RUBBERIZED UNDERCOATING (19.7 oz Can)	A/R

**NOTE**  
Material can be obtained through regular channels.

Date	Expiration	Release	Page
04.2015	04.2017	5	3(8)

## TOOLS

Use of the following specific tools is mandatory for this bulletin.

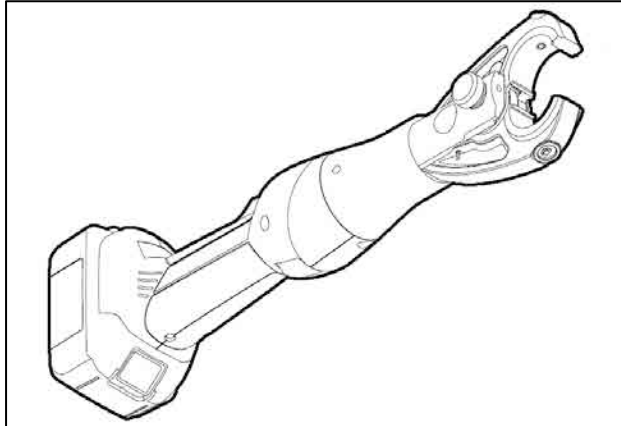

Figure 1 Greenlee Gator® EK628L



Figure 2: Greenlee® KC22 2/0 Copper Connector Die

## PROCEDURE



### DANGER

Park vehicle safely, apply parking brake, stop engine. In the battery box, set the battery cut-off switch to the OFF position prior to working on the vehicle.

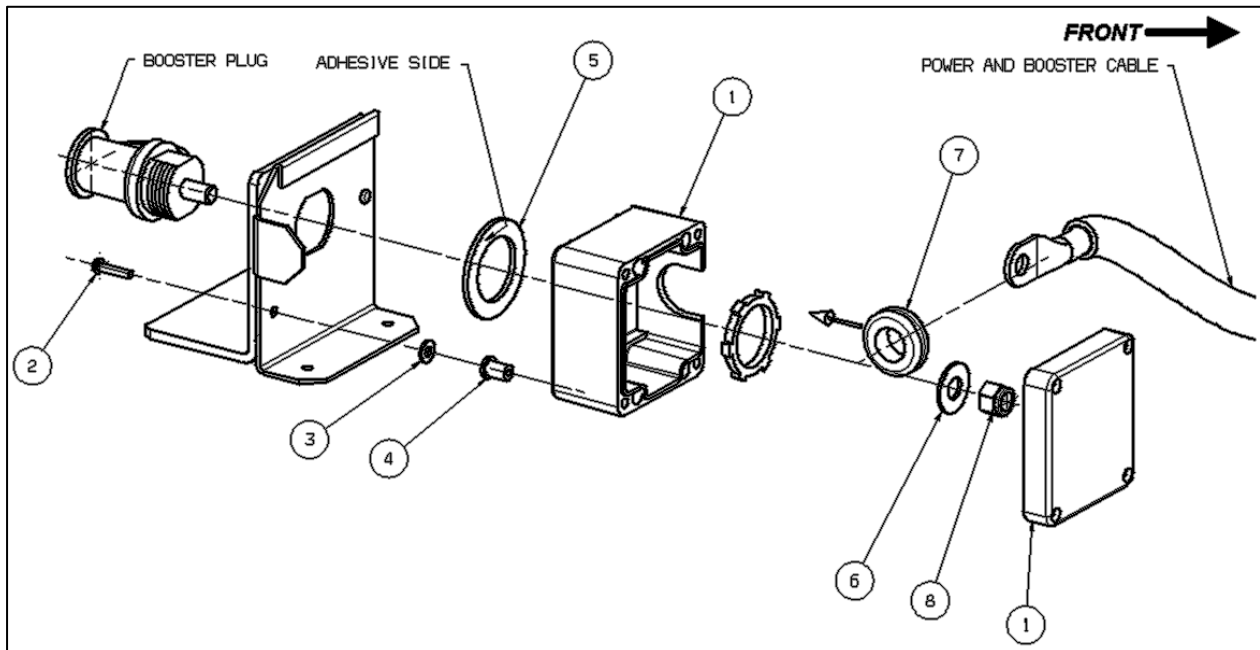

Figure 3

1. Open engine compartment R.H. side door.
2. Locate booster block positive terminal.
3. Unfasten positive terminal block fixing nut. (8), Fig. 3) remove booster block and discard.
4. Protect the auxiliary heater and cables. Remove the support bracket and fiber protector off the vehicle frame. (Fig. 4) Discard.
5. Grind flush any remaining weld.
6. Protect exposed metal with rubberized undercoating #682175.  
Refer to Appendix A for preparation and application instructions.
7. Protect bracket #063824 with the same process. Refer to appendix A.



Figure 4

8. Cut power cable just past the ring terminal where cable isolation begins. We must have un-corroded copper for the new connection. After cutting the cable, look for any trace of corrosion that may have seeped up the cable. If corrosion is found, cut the cable a little further until good copper is found.
9. Remove cable isolation and crimp new terminal #560895 according to crimp tool recommendations. Perform crimp exclusively with mandatory tools Refer to "TOOLS" section at the beginning of this document.
10. Slip *black* heat shrink tube #563156 over terminal shank and cable, as close as possible from terminal (fig. 5) Seal with heat gun.

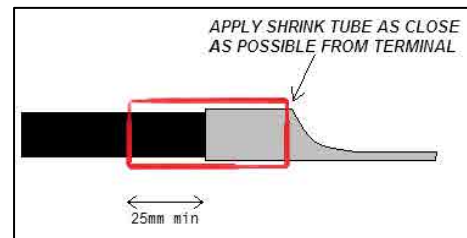

11. Slip *red* heat shrink tube #561755 over black heat shrink, seal with heat gun
12. Temporarily assemble the booster block, support bracket and newly crimped terminal "finger tight". Slide support assembly upward along the slope and wall to new support location.
13. Ensure power cable has a smooth routing and no pulling is induced as a result of the new position. **Mark new mounting holes.**

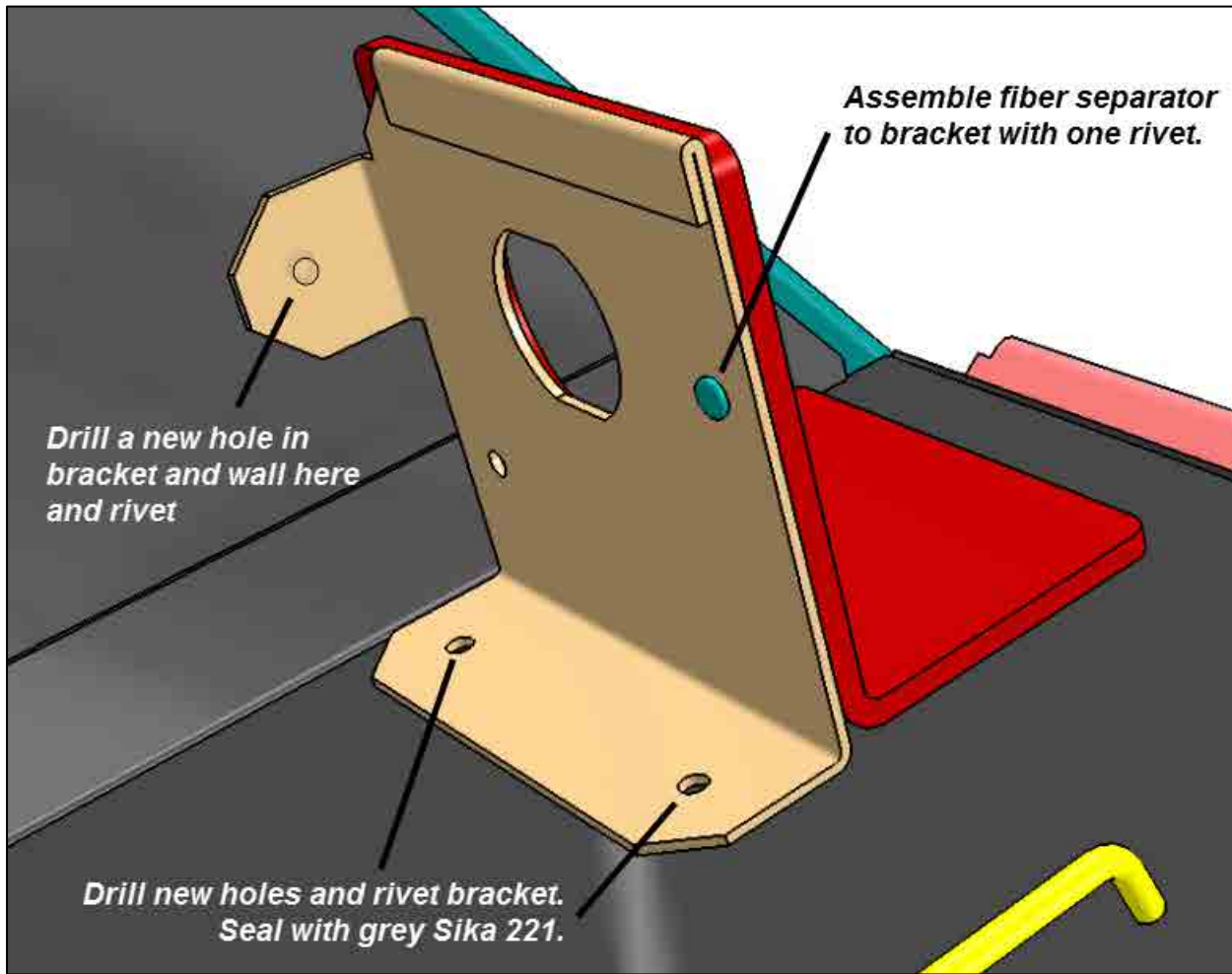

Figure 5, New Location: Bracket and fiber separator installation

14. Assemble bracket #063824 and separator #381210 with one rivet, leaving the second hole blank. (Fig 6)
15. Drill holes at previously marked locations and rivet support to frame (Fig. 6) Protect exposed side with #682175 rubberized undercoating.
16. Drill a new hole in bracket wall tab to rivet to wall.(Fig. 6)
17. Apply Sika 221 #680532 to seal holes.
18. Insert well nut **④** #500678 in protective box lower right mounting hole. (Fig 3, 7)

Date	Expiration	Release	Page
04.2015	04.2017	5	6(8)

19. Insert booster block #561856 through support hole, slide foam sealing washer ⑤ #382444 over, adhesive side towards box, and then protective box ① #382441 making sure drip hole is at the bottom. Fasten fixing nut of booster block terminal (Refer to figure 3).

20. Secure protective box ① to support using round head machine screw ② #5001305, flat washer ③ #5001137. (Fig. 3 & 7)



Figure 6

21. Install grommet ⑦ #504671 onto protective box side. (Fig. 8)

22. Pass cable ring terminal through grommet ⑦.

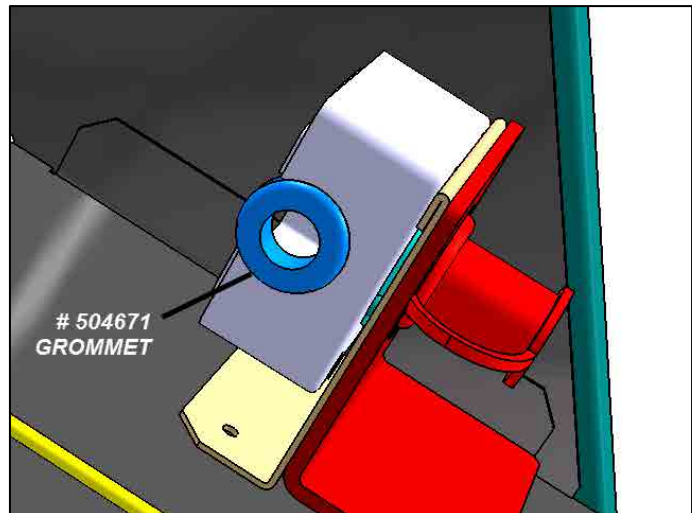

Figure 7

Date	Expiration	Release	Page
04.2015	04.2017	5	7(8)

23. Connect cable.
24. Tighten to **149 lbf-in ( $\pm 28$  lbf-in)**  
(Ref eng. spec 10.2)
25. Liberally coat nut, terminal and threaded booster block stud with "Colorguard" compound. (Fig. 9)

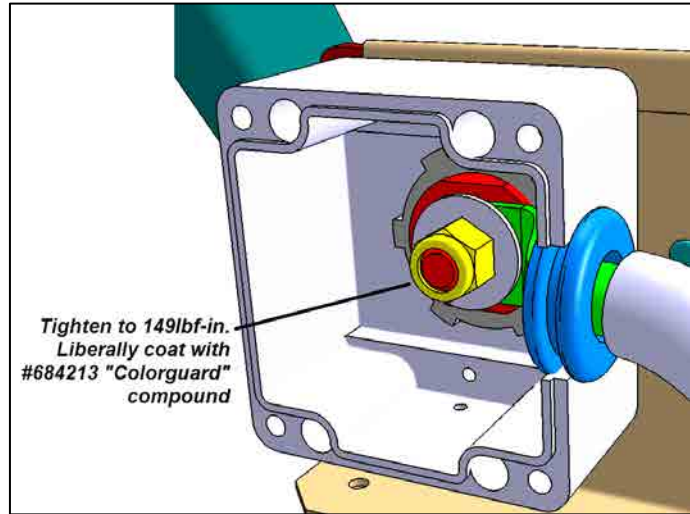

Figure 8

26. Install protective box cover. (Fig. 10)
27. Confirm proper operation.

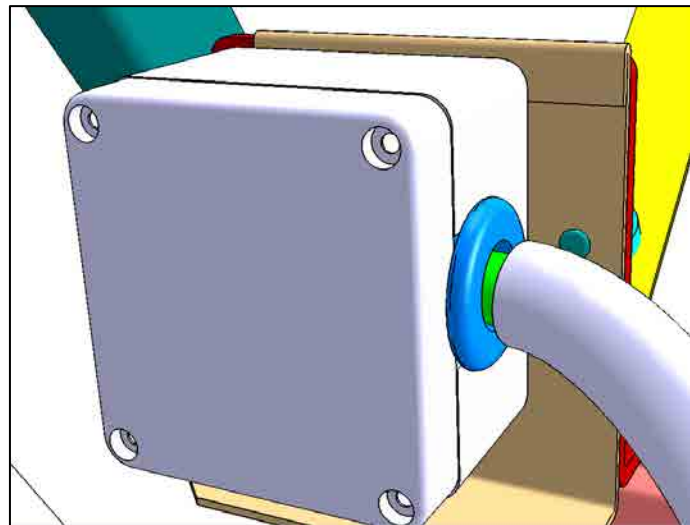

Figure 9

## APPENDIX "A": #682175 UNDERCOATING APPLICATION

Refer to product safety data sheet before undergoing any work.

1. *Product can be applied over bare metal or primer.*
2. *Clean and dry surface with soap and water, then with a Xylene - Naphta based general purpose adhesive cleaner.*
3. *Shake can thoroughly for 1 minute after the agitator ball begins to move.*
4. *Apply in relatively light coats, allowing for the solvent to evaporate somewhat between coats (3-5minutes). Build to desired thickness.*
5. *Dry time is typically 30 minutes at room temperature. Thicker applications may take longer to dry.*
6. *Product can be painted after 30 minutes (best to wait 1 hour). If waiting longer than 24 hours, scuff lightly before painting.*
7. *Always invert can and purge nozzle after use, to insure sprayability the next time.*

## **PARTS / WASTE DISPOSAL**

Return replaced parts to Prevest with A.F.A. for full reimbursement. Discard waste according to applicable environmental regulations (Municipal/State[Prov.]/ Federal)
---

## **ESTIMATED TIME**

The time required to perform this special bulletin is approximately 1 and a half hour (1h ½).

## **OTHER**

VBC Bulletin	N/A
Fail Code	06.00
Defect Code	09
System Condition	B
Causal Part	561856

Prevest engages in a continuous program of testing and evaluating to provide the best possible product. Prevest, however, is not committed to, or liable for updating existing products.