

1 12 07-15



Service Information Bulletin

SUBJECT	DATE
SPN 651 (MCM) (EPA10;GHG14); SPN 652 (MCM) (EPA10;GHG14); SPN 653 (MCM) (EPA10;GHG14); SPN 654 (MCM) (EPA10;GHG14); SPN 655 (MCM) (EPA10;GHG14); SPN 656 (MCM) (EPA10;GHG14);	December 2015

Additions, Revisions, or Updates

Publication Number / Title	Platform	Section Title	Change
DDC-SVC-MAN-0084	DD Platform - EPA10 - GHG14	SPN 651/FMI 6 - EPA10 - GHG14	Updated procedures with adding EPA10 to the GHG14 title.
		SPN 652/FMI 6 - EPA10 - GHG14	
		SPN 653/FMI 6 - EPA10 - GHG14	
		SPN 654/FMI 6 - EPA10 - GHG14	
		SPN 655/FMI 6 - EPA10 - GHG14	
		SPN 656/FMI 6 - EPA10 - GHG14	

DiagnosticLink® users: Please update the troubleshooting guides in DiagnosticLink with this newest version. To update the tool troubleshooting guide, open DiagnosticLink and from the Help - Troubleshooting Guides menu, select the appropriate troubleshooting manual, then click Update.



13400 Outer Drive, West, Detroit, Michigan 48239-4001
Telephone: 313-592-5000
www.demanddetroit.com

2 SPN 651/FMI 6 - EPA10 - GHG14

Injector Cylinder #1 Needle Control Valve Shorted Circuit

Table 1.

SPN 651/FMI 6	
Description	Injector Cylinder #1 Needle Control Valve Shorted Circuit
Monitored Parameter	Injector Cylinder #1 Needle Control Valve
Typical Enabling Conditions	Engine rpm = idle or higher
Monitor Sequence	None
Execution Frequency	Continuous when enabling conditions met
Typical Duration	Two Seconds
Dash Lamps	MIL, CEL
Engine Reaction	Derate 25%
Verification	Engine Idle (one minute)

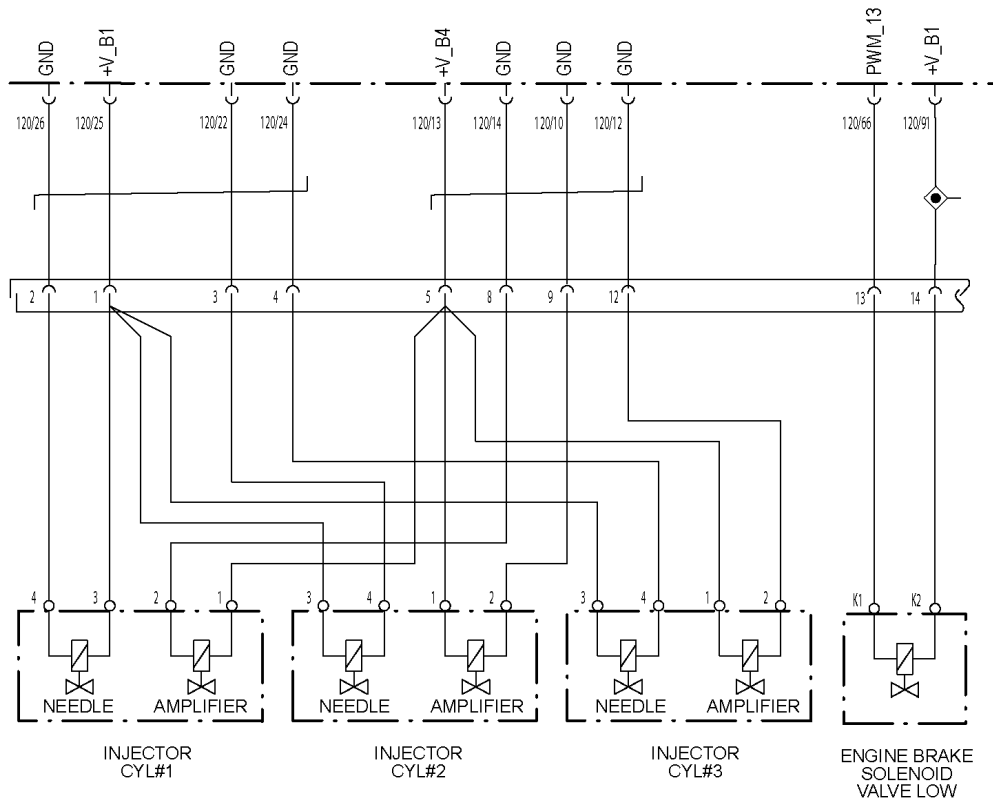

d150021

Check as follows:

NOTE: Submit completed diagnostics with warranty claim.

NOTE: Injector chart PDF available on DDCSN/SUPPORT/SPECIALIZED SERVICE.

1. Check for multiple codes. Using DiagnosticLink[®], retain log file of active fault and clear codes (code active for one key cycle).

- a. If SPN fault code 168 or 723/FMI any is present, service those faults first.
 - b. If SPN fault code 168 or 723/FMI any is NOT present, Go to step 2.
2. Check the warranty claim history. Check with driver. Is this the first occurrence of this fault within the last 30 days?
- a. Yes; Go to step 3.
 - b. No; complete diagnostics, retain a log file of active fault and the measured resistance values recorded in this procedure and contact the Customer Support Center at 800-445-1980.



WARNING: ENGINE EXHAUST

To avoid injury from inhaling engine exhaust, always operate the engine in a well-ventilated area. Engine exhaust is toxic.



WARNING: PERSONAL INJURY

To avoid injury before starting and running the engine, ensure the vehicle is parked on a level surface, parking brake is set, and the wheels are blocked.

- 3. Start and warm the engine until the coolant temperature is above 71°C (160°F).
- 4. Turn the engine OFF.
- 5. Disconnect the front fuel injector harness 14-pin connector.
- 6. Inspect the front fuel injector harness 14-pin injector connectors for bent or spread pins; inspect the connector seal for damage (signs of water or oil intrusion).
 - a. If water or oil intrusion, bent or spread pins are found, repair as necessary.
 - b. If the connector shows no signs of damage, Go to step 7.

NOTE: DO NOT touch the metal ohmmeter leads with your hands when the measurements are made.

- 7. Using the appropriate chart below, measure and record the resistance values between the corresponding pins on the valve cover side of the front fuel injector harness listed below. Are the resistances within range?

Table 2.

Front Fuel Injector Harness 14-Pin Connector Resistance Chart (Valve Cover Side)				
Injector #1 Needle	Pins 1 and 2	Pins 1 and 8	Pin 2 and ground	Pin 8 and ground
	1.3 to 2.5Ω*	Greater than 100kΩ*	Greater than 100kΩ*	Greater than 100kΩ*
	Ω	Ω	Ω	Ω
Injector #2 Needle	Pins 1 and 3	Pins 1 and 9	Pin 3 and ground	Pin 9 and ground
	1.3 to 2.5Ω*	Greater than 100kΩ*	Greater than 100kΩ*	Greater than 100kΩ*
	Ω	Ω	Ω	Ω
Injector #3 Needle	Pins 1 and 4	Pins 1 and 12	Pin 4 and ground	Pin 12 and ground
	1.3 to 2.5Ω*	Greater than 100kΩ*	Greater than 100kΩ*	Greater than 100kΩ*
	Ω	Ω	Ω	Ω
* = acceptable resistance				

VALVE COVER SIDE

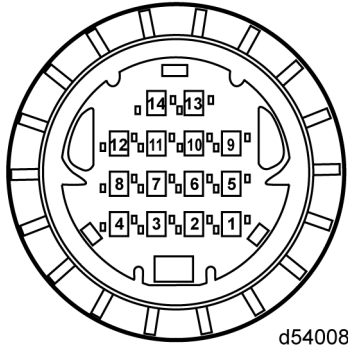

d540083

Table 3.

Front Fuel Injector Harness 14-Pin Connector Resistance Chart (Using J-48671-10 Injector Breakout Box)				
Note: Ensure J-48671-10 ground strap is connected to cylinder head.				
Injector #1 Needle	Pins 3 and 4	Pins 2 and 3	Pin 2 and ground	Pin 3 and ground
	1.3 to 2.5Ω*	Greater than 100kΩ*	Greater than 100kΩ*	Greater than 100kΩ*
	Ω	Ω	Ω	Ω
Injector #2 Needle	Pins 3 and 4	Pins 2 and 3	Pin 2 and ground	Pin 3 and ground
	1.3 to 2.5Ω*	Greater than 100kΩ*	Greater than 100kΩ*	Greater than 100kΩ*
	Ω	Ω	Ω	Ω
Injector #3 Needle	Pins 3 and 4	Pins 2 and 3	Pin 2 and ground	Pin 3 and ground
	1.3 to 2.5Ω*	Greater than 100kΩ*	Greater than 100kΩ*	Greater than 100kΩ*
	Ω	Ω	Ω	Ω
* = acceptable resistance				

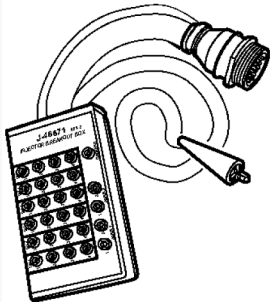

d580085

- a. Yes; Go to step 11.
- b. No; Go to step 8.

8. Remove the rocker cover. Refer to section "Removal of the Rocker Cover".
9. Remove the front fuel injector harness from the engine.
Refer to section "Removal of the Two-Piece Fuel Injector Wiring Harness - Three-Filter System".
Refer to section "Removal of the Two-Piece Fuel Injector Wiring Harness - Two-Filter System".

NOTE: DO NOT touch the metal ohmmeter leads with your hands when the measurements are made.

10. Using the chart below, measure and record the resistance values between the injector pins listed below. Are the resistance values within range?

Table 4.

Injector Needle Resistance Chart (Injector Harness must be removed from engine)				
Injector #1 Needle	Pins 3 and 4	Pins 3 and 2	Pin 2 and ground	Pin 3 and ground
	2.0Ω or less*	Greater than 100kΩ*	Greater than 100kΩ*	Greater than 100kΩ*
	Ω	Ω	Ω	Ω
Injector #2 Needle	Pins 3 and 4	Pins 3 and 2	Pin 2 and ground	Pin 3 and ground
	2.0Ω or less*	Greater than 100kΩ*	Greater than 100kΩ*	Greater than 100kΩ*
	Ω	Ω	Ω	Ω
Injector #3 Needle	Pins 3 and 4	Pins 3 and 2	Pin 2 and ground	Pin 3 and ground
	2.0Ω or less*	Greater than 100kΩ*	Greater than 100kΩ*	Greater than 100kΩ*
	Ω	Ω	Ω	Ω
* = acceptable resistance				

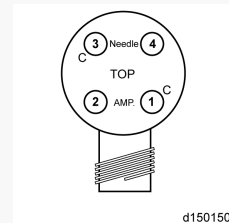

- a. Yes; replace the front fuel injector harness.
Refer to section "Removal of the Two-Piece Fuel Injector Wiring Harness - Three-Filter System".
Refer to section "Removal of the Two-Piece Fuel Injector Wiring Harness - Two-Filter System".
- b. No; replace the injector with the out-of-range resistance.
Refer to section "Removal of the Fuel Injector - Three-Filter System".
Refer to section "Removal of the Fuel Injector - Two-Filter System".

11. Disconnect the Motor Control Module (MCM) 120-pin connector.
12. Using the chart below, measure and record the resistance values between the engine side of the front valve cover 14-pin connector and the MCM 120-pin connector. Are the resistances within range?

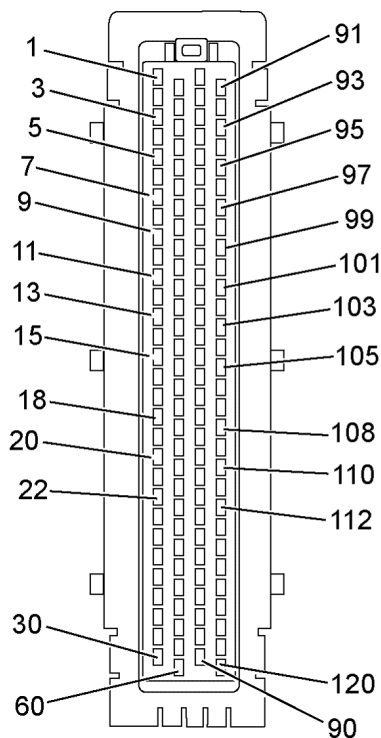

ENGINE HARNESS SIDE

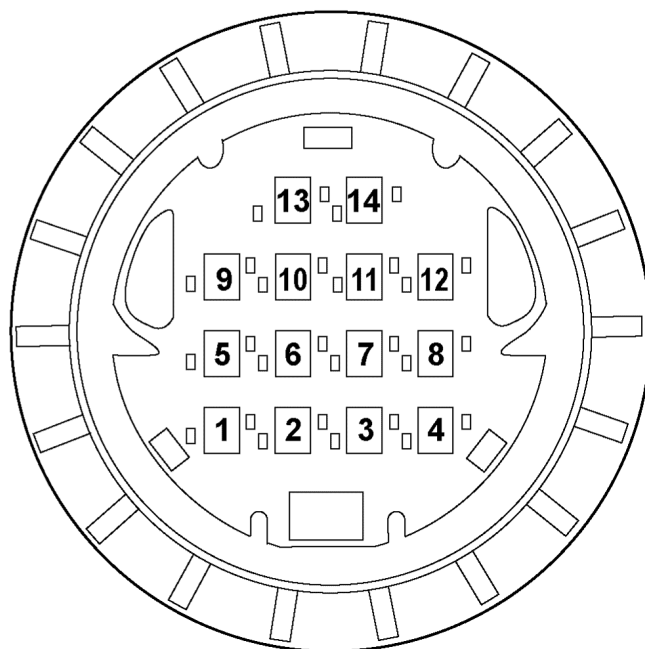

d540080

- a. If signs of damage are found, repair as necessary. Verify repairs.
- b. If no signs of damage, Go to step 13.

NOTE: DO NOT touch the metal ohmmeter leads with your hands when the measurements are made.

13. Using the chart below, measure and record the resistance values between the engine side of the front valve cover 14-pin connector and the MCM 120-pin connector. Are the resistances within range?

Table 5.

Engine Harness Injector Circuit Resistance Table				
Front Engine Side Valve Cover 14-pin connector #	MCM 120-Pin Harness Connector	Acceptable Resistance 1Ω or less	Front Engine Side Valve Cover 14 pin connector #	Acceptable Resistance 1KΩ or greater
1	25	Ω	1 and ground	Ω
2	26	Ω	2 and ground	Ω
3	22	Ω	3 and ground	Ω
4	24	Ω	4 and ground	Ω

- a. Yes; Go to step 14.
- b. No; repair the engine side harness. Verify repairs.

NOTE: The use of extension harness J-49120 will ease installation of test MCM.

14. Install a test MCM.
15. Reconnect all connections and start engine. Bring to operating temperature of 71°C (160°F). Road test the vehicle for 30 minutes. Does fault become active?
 - a. Yes; repeat all steps. If results are the same, retain a log file of active fault and the measured resistance values recorded in this procedure and contact the Customer Support Center at 800-445-1980 for further instructions.
 - b. No; Go to step 16.
16. Install original MCM. Bring to operating temperature of 71°C (160°F). Road test the vehicle for 30 minutes. Does fault become active?
 - a. Yes; retain log file of active fault. Replace the MCM. Refer to section "Removal of the Motor Control Module".
 - b. No; release vehicle.

3 SPN 652/FMI 6 - EPA10 - GHG14

Injector Cylinder #2 Needle Control Valve Shorted Circuit

Table 6.

SPN 652/FMI 6	
Description	Injector Cylinder #2 Needle Control Valve, Valve Shorted Circuit
Monitored Parameter	Injector Cylinder #2 Needle Control Valve
Typical Enabling Conditions	Engine rpm = idle or higher
Monitor Sequence	None
Execution Frequency	Continuous when enabling conditions met
Typical Duration	Two Seconds
Dash Lamps	MIL, CEL
Engine Reaction	Derate 25%
Verification	Engine Idle (one minute)

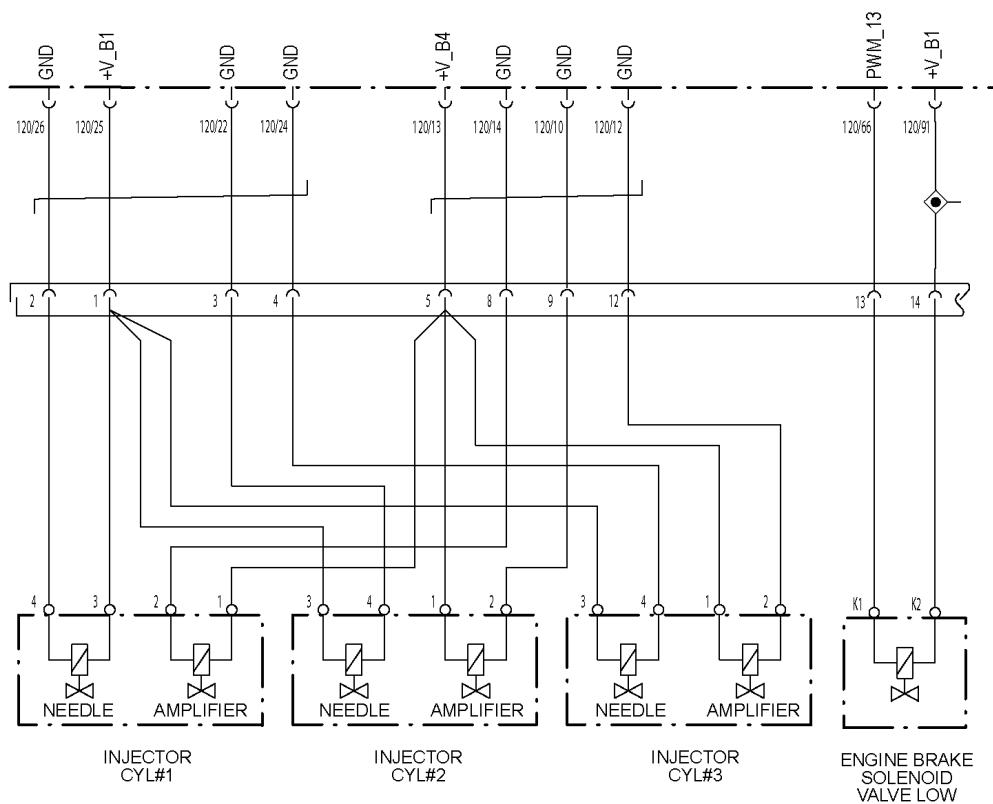

d150021

Check as follows:

NOTE: Submit completed diagnostics with warranty claim.

NOTE: Injector chart PDF available on DDCSN/SUPPORT/SPECIALIZED SERVICE.

1. Check for multiple codes. Using DiagnosticLink[®], retain log file of active fault and clear codes (code active for one key cycle).

- a. If SPN fault code 168 or 723/FMI any is present, service those faults first.
 - b. If SPN fault code 168 or 723/FMI any is NOT present, Go to step 2.
2. Check the warranty claim history. Check with driver. Is this the first occurrence of this fault within the last 30 days?
 - a. Yes; Go to step 3.
 - b. No; complete diagnostics, retain a log file of active fault and the measured resistance values recorded in this procedure and contact the Customer Support Center at 800-445-1980.



WARNING: ENGINE EXHAUST

To avoid injury from inhaling engine exhaust, always operate the engine in a well-ventilated area. Engine exhaust is toxic.



WARNING: PERSONAL INJURY

To avoid injury before starting and running the engine, ensure the vehicle is parked on a level surface, parking brake is set, and the wheels are blocked.

3. Start and warm the engine until the coolant temperature is above 71°C (160°F).
4. Turn the engine OFF.
5. Disconnect the front rocker cover 14-pin injector harness connector.
6. Inspect the front injector harness 14-pin injector connectors for bent or spread pins. Inspect the connector seal for damage (signs of water or oil intrusion).
 - a. If water or oil intrusion, bent or spread pins are found, repair as necessary.
 - b. If the connector shows no signs of damage, Go to step 7.

NOTE: DO NOT touch the metal ohmmeter leads with your hands when the measurements are made.

7. Using the appropriate chart below, measure and record the resistance values between the corresponding pins on the valve cover side of the front injector harness listed below. Are the resistances within range?

Table 7.

Front Fuel Injector Harness 14-Pin Connector Resistance Chart (Valve Cover Side)				
Injector #1 Needle	Pins 1 and 2	Pins 1 and 8	Pin 2 and ground	Pin 8 and ground
	1.3 to 2.5Ω*	Greater than 100kΩ*	Greater than 100kΩ*	Greater than 100kΩ*
	Ω	Ω	Ω	Ω
Injector #2 Needle	Pins 1 and 3	Pins 1 and 9	Pin 3 and ground	Pin 9 and ground
	1.3 to 2.5Ω*	Greater than 100kΩ*	Greater than 100kΩ*	Greater than 100kΩ*
	Ω	Ω	Ω	Ω
Injector #3 Needle	Pins 1 and 4	Pins 1 and 12	Pin 4 and ground	Pin 12 and ground
	1.3 to 2.5Ω*	Greater than 100kΩ*	Greater than 100kΩ*	Greater than 100kΩ*
	Ω	Ω	Ω	Ω
* = acceptable resistance				

VALVE COVER SIDE

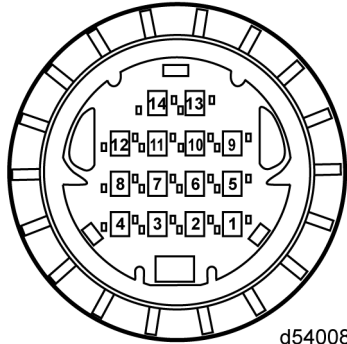

d540083

Table 8.

Front Fuel Injector Harness 14-Pin Connector Resistance Chart (Using J-48671-10 Injector Breakout Box)				
Note: Ensure J-48671-10 ground strap is connected to cylinder head.				
Injector #1 Needle	Pins 3 and 4	Pins 2 and 3	Pin 2 and ground	Pin 3 and ground
	1.3 to 2.5Ω*	Greater than 100kΩ*	Greater than 100kΩ*	Greater than 100kΩ*
	Ω	Ω	Ω	Ω
Injector #2 Needle	Pins 3 and 4	Pins 2 and 3	Pin 2 and ground	Pin 3 and ground
	1.3 to 2.5Ω*	Greater than 100kΩ*	Greater than 100kΩ*	Greater than 100kΩ*
	Ω	Ω	Ω	Ω
Injector #3 Needle	Pins 3 and 4	Pins 2 and 3	Pin 2 and ground	Pin 3 and ground
	1.3 to 2.5Ω*	Greater than 100kΩ*	Greater than 100kΩ*	Greater than 100kΩ*
	Ω	Ω	Ω	Ω
* = acceptable resistance				

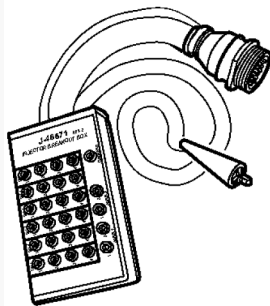

d580085

- a. Yes; Go to step 11.
- b. No; Go to step 8.

8. Remove the rocker cover. Refer to section "Removal of the Rocker Cover".
9. Remove the front fuel injector harness from the engine.
Refer to section "Removal of the Two-Piece Fuel Injector Wiring Harness - Three-Filter System".
Refer to section "Removal of the Two-Piece Fuel Injector Wiring Harness - Two-Filter System".

NOTE: DO NOT touch the metal ohmmeter leads with your hands when the measurements are made.

10. Using the chart below, measure and record the resistance values between the injector pins listed below. Are the resistances within range?

Table 9.

Injector Needle Resistance Chart (Injector Harness must be removed from engine)					
Injector #1 Needle	Pins 3 and 4	Pins 3 and 2	Pin 2 and ground	Pin 3 and ground	
	2.0Ω or less*	Greater than 100kΩ*	Greater than 100kΩ*	Greater than 100kΩ*	
	Ω	Ω	Ω	Ω	
Injector #2 Needle	Pins 3 and 4	Pins 3 and 2	Pin 2 and ground	Pin 3 and ground	
	2.0Ω or less*	Greater than 100kΩ*	Greater than 100kΩ*	Greater than 100kΩ*	
	Ω	Ω	Ω	Ω	
Injector #3 Needle	Pins 3 and 4	Pins 3 and 2	Pin 2 and ground	Pin 3 and ground	
	2.0Ω or less*	Greater than 100kΩ*	Greater than 100kΩ*	Greater than 100kΩ*	
	Ω	Ω	Ω	Ω	
* = acceptable resistance					

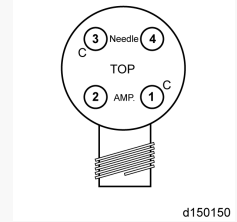

- a. Yes; replace the front fuel injector harness.
Refer to section "Removal of the Two-Piece Fuel Injector Wiring Harness - Three-Filter System".
Refer to section "Removal of the Two-Piece Fuel Injector Wiring Harness - Two-Filter System".
- b. No; replace the injector with the out-of-range resistance.
Refer to section "Removal of the Fuel Injector - Three-Filter System".
Refer to section "Removal of the Fuel Injector - Two-Filter System".

11. Disconnect the Motor Control Module (MCM) 120-pin connector.
12. Inspect the MCM 120-pin connector and 120-pin harness connector for signs of corrosion, spread, unseated (pushed out) or damaged pins, connector seal for damage (signs of water or oil intrusion) or signs of wire damage.

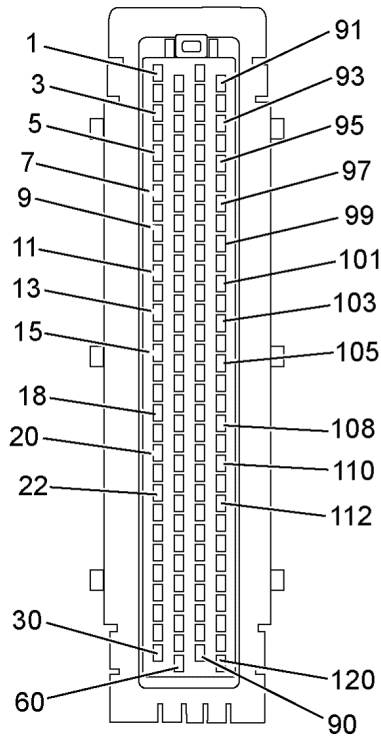

ENGINE HARNESS SIDE

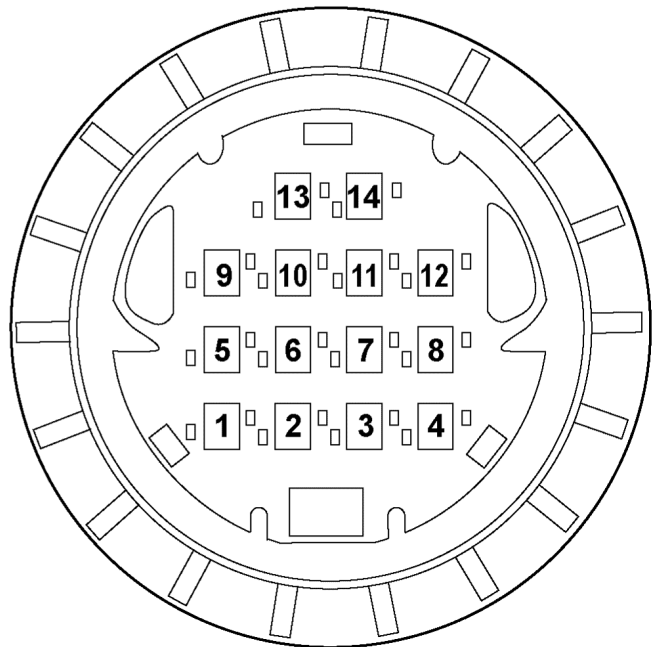

d540080

- a. If signs of damage are found, repair as necessary. Verify repairs.
- b. If no signs of damage, Go to step 13.

NOTE: DO NOT touch the metal ohmmeter leads with your hands when the measurements are made.

13. Using the chart below, measure and record the resistance values between the engine harness side of the front valve cover 14-pin connector and the MCM 120-pin harness connector. Are the resistances within range?

Table 10.

Engine Harness Injector Circuit Resistance Table				
Front Engine Side Valve Cover 14-pin connector #	MCM 120-Pin Harness Connector	Acceptable Resistance 1 Ω or less	Front Engine Side Valve Cover 14 pin connector #	Acceptable Resistance 1K Ω or greater
1	25	Ω	1 and ground	Ω
2	26	Ω	2 and ground	Ω
3	22	Ω	3 and ground	Ω
4	24	Ω	4 and ground	Ω

- a. Yes; Go to step 14.
- b. No; repair the engine side harness. Verify repairs.

NOTE: The use of extension harness J-49120 will ease installation of test MCM.

14. Install a test MCM.
15. Reconnect all connections and start engine. Bring to operating temperature of 71°C (160°F). Road test the vehicle for 30 minutes. Does fault become active?
 - a. Yes; repeat all steps. If results are the same, retain a log file of active fault and the measured resistance values recorded in this procedure and contact the Customer Support Center at 800-445-1980 for further instructions.
 - b. No; Go to step 16.
16. Install original MCM. Bring to operating temperature of 71°C (160°F). Road test the vehicle for 30 minutes. Does fault become active?
 - a. Yes; retain log file of active fault. Replace the MCM. Refer to section "Removal of the Motor Control Module".
 - b. No; release vehicle.

4 SPN 653/FMI 6 - EPA10 - GHG14

Injector Cylinder #3 Needle Control Valve Shorted Circuit

Table 11.

SPN 653/FMI 6	
Description	Injector Cylinder #3 Needle Control Valve Shorted Circuit
Monitored Parameter	Injector Cylinder #3 Needle Control Valve
Typical Enabling Conditions	Engine rpm = idle or higher
Monitor Sequence	None
Execution Frequency	Continuous when enabling conditions met
Typical Duration	Two Seconds
Dash Lamps	MIL, CEL
Engine Reaction	Derate 25%
Verification	Engine Idle (one minute)

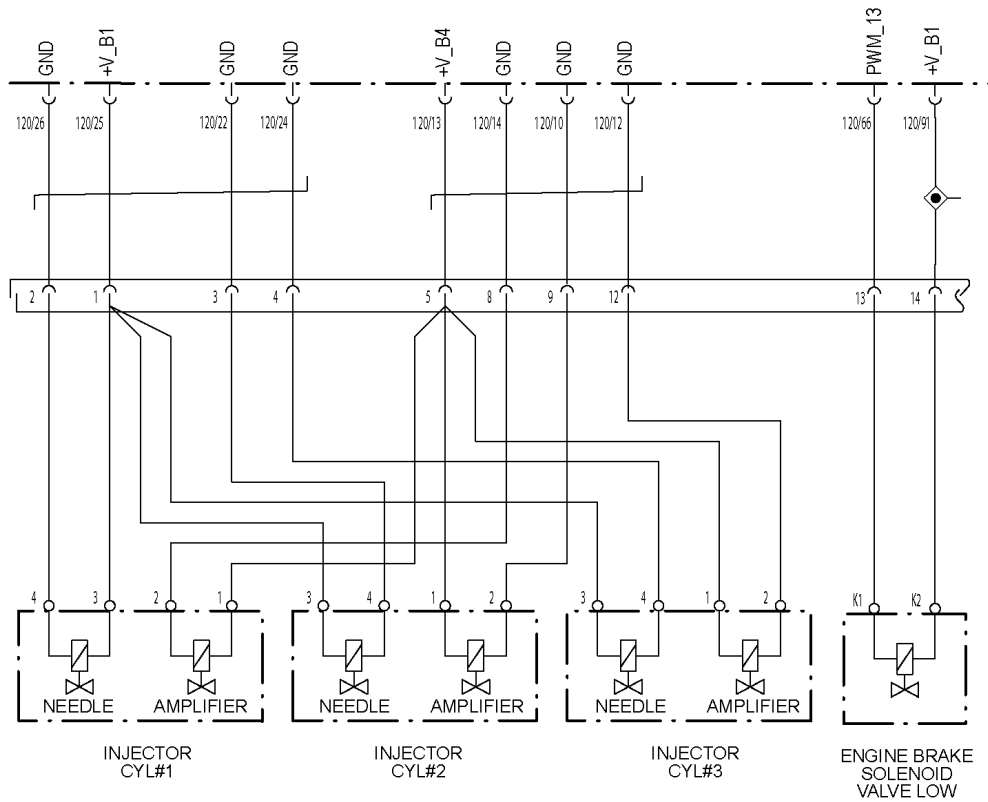

d150021

Check as follows:

NOTE: Submit completed diagnostics with warranty claim.

NOTE: Injector chart PDF available on DDCSN/SUPPORT/SPECIALIZED SERVICE.

1. Check for multiple codes. Using DiagnosticLink[®], retain log file of active fault and clear codes (code active for one key cycle).

- a. If SPN fault code 168 or 723/FMI any is present, service those faults first.
 - b. If SPN fault code 168 or 723/FMI any is NOT present, Go to step 2.
2. Check the warranty claim history. Check with driver. Is this the first occurrence of this fault within the last 30 days?
 - a. Yes; Go to step 3.
 - b. No; complete diagnostics, retain a log file of active fault and the measured resistance values recorded in this procedure and contact the Customer Support Center at 800-445-1980.

WARNING: ENGINE EXHAUST

To avoid injury from inhaling engine exhaust, always operate the engine in a well-ventilated area. Engine exhaust is toxic.

WARNING: PERSONAL INJURY

To avoid injury before starting and running the engine, ensure the vehicle is parked on a level surface, parking brake is set, and the wheels are blocked.

3. Start and warm the engine until the coolant temperature is above 71°C (160°F).
4. Turn the engine OFF.
5. Disconnect the front rocker cover 14-pin injector harness connector.
6. Inspect the front injector harness 14-pin injector connectors for bent or spread pins. Inspect the connector seal for damage (signs of water or oil intrusion).
 - a. If water or oil intrusion, bent or spread pins are found, repair as necessary.
 - b. If the connector shows no signs of damage, Go to step 7.

NOTE: DO NOT touch the metal ohmmeter leads with your hands when the measurements are made.

7. Using the appropriate chart below, measure and record the resistance values between the corresponding pins on the valve cover side of the front injector harness listed below. Are the resistances within range?

Table 12.

Front Fuel Injector Harness 14-Pin Connector Resistance Chart (Valve Cover Side)				
Injector #1 Needle	Pins 1 and 2	Pins 1 and 8	Pin 2 and ground	Pin 8 and ground
	1.3 to 2.5Ω*	Greater Than 100kΩ*	Greater Than 100kΩ*	Greater Than 100kΩ*
	Ω	Ω	Ω	Ω
Injector #2 Needle	Pins 1 and 3	Pins 1 and 9	Pin 3 and ground	Pin 9 and ground
	1.3 to 2.5Ω*	Greater Than 100kΩ*	Greater Than 100kΩ*	Greater Than 100kΩ*
	Ω	Ω	Ω	Ω
Injector #3 Needle	Pins 1 and 4	Pins 1 and 12	Pin 4 and ground	Pin 12 and ground
	1.3 to 2.5Ω*	Greater Than 100kΩ*	Greater Than 100kΩ*	Greater Than 100kΩ*
	Ω	Ω	Ω	Ω
* = acceptable resistance				

VALVE COVER SIDE

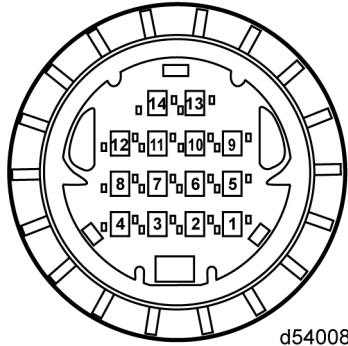

d540083

Table 13.

Front Fuel Injector Harness 14-Pin Connector Resistance Chart (Using J-48671-10 Injector Breakout Box)				
Note: Ensure J-48671-10 ground strap is connected to cylinder head.				
Injector #1 Needle	Pins 3 and 4	Pins 2 and 3	Pin 2 and ground	Pin 3 and ground
	1.3 to 2.5Ω*	Greater Than 100kΩ*	Greater Than 100kΩ*	Greater Than 100kΩ*
	Ω	Ω	Ω	Ω
Injector #2 Needle	Pins 3 and 4	Pins 2 and 3	Pin 2 and ground	Pin 3 and ground
	1.3 to 2.5Ω*	Greater Than 100kΩ*	Greater Than 100kΩ*	Greater Than 100kΩ*
	Ω	Ω	Ω	Ω
Injector #3 Needle	Pins 3 and 4	Pins 2 and 3	Pin 2 and ground	Pin 3 and ground
	1.3 to 2.5Ω*	Greater Than 100kΩ*	Greater Than 100kΩ*	Greater Than 100kΩ*
	Ω	Ω	Ω	Ω
* = acceptable resistance				



d580085

- a. Yes; Go to step 11.
- b. No; Go to step 8.

8. Remove the rocker cover. Refer to section "Removal of the Rocker Cover".
9. Remove the front fuel injector harness from the engine.
Refer to section "Removal of the Two-Piece Fuel Injector Wiring Harness - Three-Filter System".
Refer to section "Removal of the Two-Piece Fuel Injector Wiring Harness - Two-Filter System".

NOTE: DO NOT touch the metal ohmmeter leads with your hands when the measurements are made.

10. Using the chart below, measure and record the resistance values between the injector pins listed below. Are the resistances within range?

Table 14.

Injector Needle Resistance Chart (Injector Harness must be removed from engine)					
Injector #1 Needle	Pins 3 and 4	Pins 3 and 2	Pin 2 and ground	Pin 3 and ground	
	2.0Ω or less*	Greater Than 100kΩ*	Greater Than 100kΩ*	Greater Than 100kΩ*	
	Ω	Ω	Ω	Ω	
Injector #2 Needle	Pins 3 and 4	Pins 3 and 2	Pin 2 and ground	Pin 3 and ground	
	2.0Ω or less*	Greater Than 100kΩ*	Greater Than 100kΩ*	Greater Than 100kΩ*	
	Ω	Ω	Ω	Ω	
Injector #3 Needle	Pins 3 and 4	Pins 3 and 2	Pin 2 and ground	Pin 3 and ground	
	2.0Ω or less*	Greater Than 100kΩ*	Greater Than 100kΩ*	Greater Than 100kΩ*	
	Ω	Ω	Ω	Ω	
* = acceptable resistance					

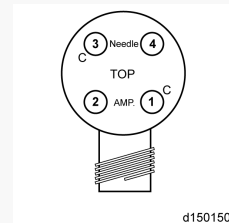

- a. Yes; replace the front fuel injector harness.
Refer to section "Removal of the Two-Piece Fuel Injector Wiring Harness - Three-Filter System".
Refer to section "Removal of the Two-Piece Fuel Injector Wiring Harness - Two-Filter System".
 - b. No; replace the injector with the out-of-range resistance.
Refer to section "Removal of the Fuel Injector - Three-Filter System".
Refer to section "Removal of the Fuel Injector - Two-Filter System".
11. Disconnect the Motor Control Module (MCM) 120-pin connector.
 12. Inspect the MCM 120-pin connector and 120-pin harness connector for signs of corrosion, spread, unseated (pushed out) or damaged pins, connector seal for damage (signs of water or oil intrusion) or signs of wire damage.
 - a. If signs of damage are found, repair as necessary. Verify repairs.
 - b. If no signs of damage, Go to step 13.

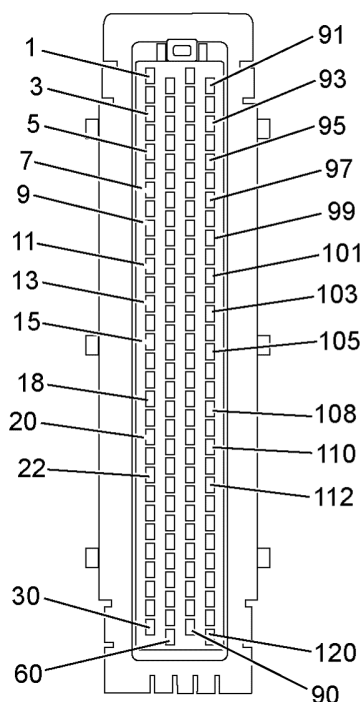

ENGINE HARNESS SIDE

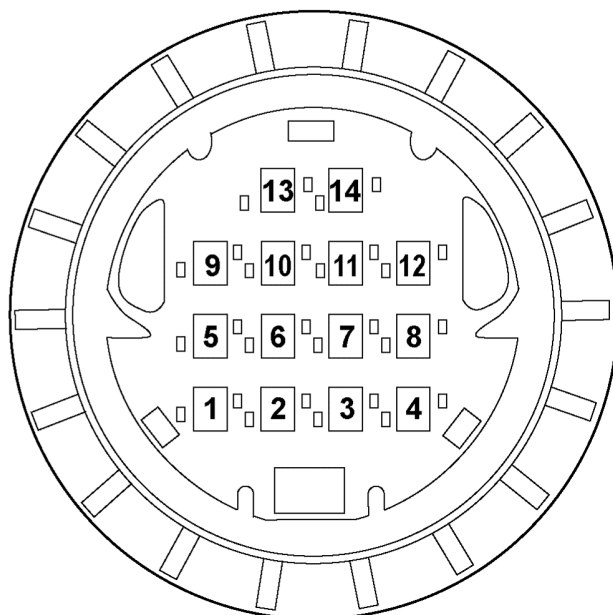

d540080

NOTE: DO NOT touch the metal ohmmeter leads with your hands when the measurements are made.

13. Using the chart below, measure and record the resistance values between the engine side of the front valve cover 14-pin connector and the MCM 120-pin connector. Are the resistances within range?

Table 15.

Engine Harness Injector Circuit Resistance Table				
Front Engine Side Valve Cover 14-pin connector #	MCM 120-Pin Harness Connector	Acceptable Resistance 1Ω or less	Front Engine Side Valve Cover 14 pin connector #	Acceptable Resistance 1KΩ or greater
1	25	Ω	1 and ground	Ω
2	26	Ω	2 and ground	Ω
3	22	Ω	3 and ground	Ω
4	24	Ω	4 and ground	Ω

- a. Yes; Go to step 14.
b. No; repair the engine side harness. Verify repairs.

NOTE: The use of extension harness J-49120 will ease installation of test MCM.

14. Install a test MCM.
15. Reconnect all connections and start engine. Bring to operating temperature of 71°C (160°F). Road test the vehicle for 30 minutes. Does fault become active?
a. Yes; repeat all steps. If results are the same, retain a log file of active fault and the measured resistance values recorded in this procedure and contact the Customer Support Center at 800-445-1980 for further instructions.
b. No; Go to step 16.
16. Install original MCM. Bring to operating temperature of 71°C (160°F). Road test the vehicle for 30 minutes. Does fault become active?
a. Yes; retain log file of active fault. Replace the MCM. Refer to section "Removal of the Motor Control Module".
b. No; release vehicle.

5 SPN 654/FMI 6 - EPA10 - GHG14

Injector Cylinder #4 Needle Control Valve Shorted Circuit

Table 16.

SPN 654/FMI 6	
Description	Injector Cylinder #4 Needle Control Valve Shorted Circuit
Monitored Parameter	Injector Cylinder #4 Needle Control Valve
Typical Enabling Conditions	Engine rpm = idle or higher
Monitor Sequence	None
Execution Frequency	Continuous when enabling conditions met
Typical Duration	Two Seconds
Dash Lamps	MIL, CEL
Engine Reaction	Derate 25%
Verification	Engine Idle (one minute)

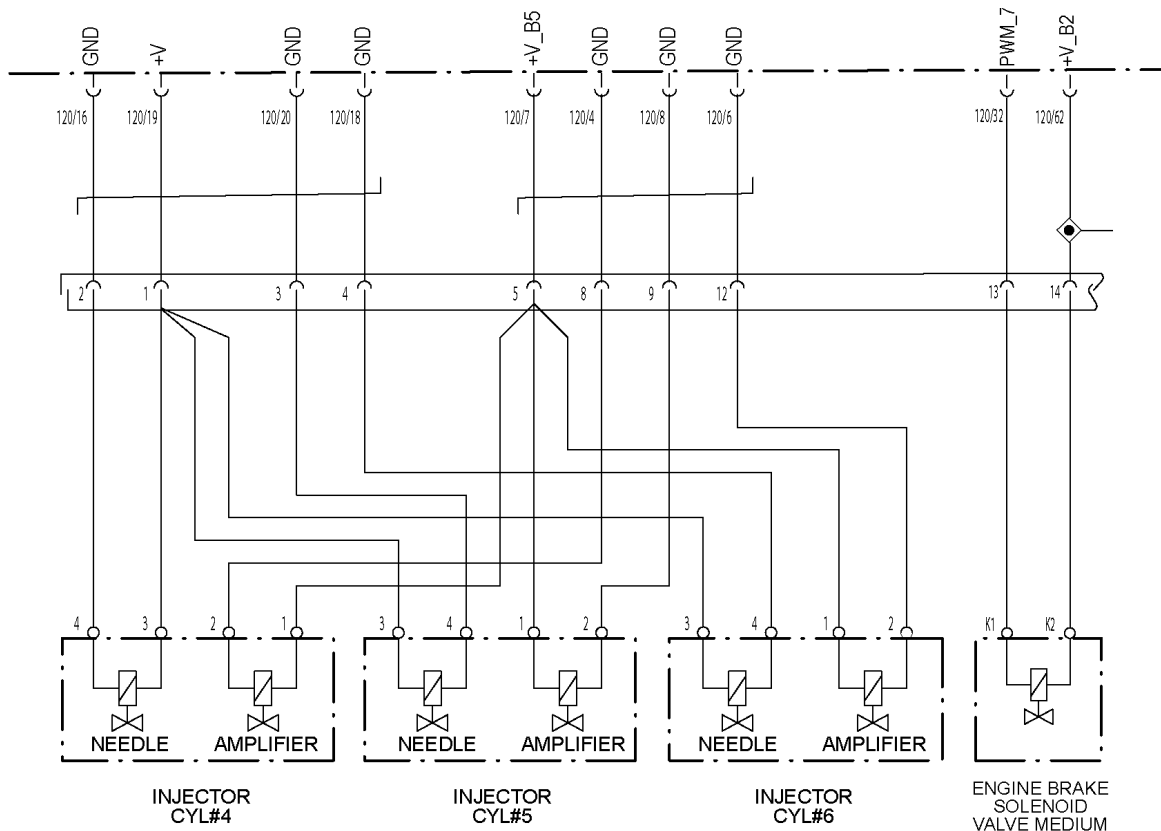

d150022

Check as follows:

NOTE: Submit completed diagnostics with warranty claim.

NOTE: Injector chart PDF available on DDCSN/SUPPORT/SPECIALIZED SERVICE.

1. Check for multiple codes. Using DiagnosticLink[®], retain log file of active fault and clear codes (code active for one key cycle).

- a. If SPN fault code 168 or 723/FMI any is present, service those faults first.
 - b. If SPN fault code 168 or 723/FMI any is NOT present, Go to step 2.
2. Check the warranty claim history. Check with driver. Is this the first occurrence of this fault within the last 30 days?
 - a. Yes; Go to step 3.
 - b. No; complete diagnostics, retain a log file of active fault and the measured resistance values recorded in this procedure and contact the Customer Support Center at 800-445-1980.

**WARNING: ENGINE EXHAUST**

To avoid injury from inhaling engine exhaust, always operate the engine in a well-ventilated area. Engine exhaust is toxic.

**WARNING: PERSONAL INJURY**

To avoid injury before starting and running the engine, ensure the vehicle is parked on a level surface, parking brake is set, and the wheels are blocked.

3. Start and warm the engine until the coolant temperature is above 71°C (160°F).
4. Turn the engine OFF.
5. Disconnect the rear rocker cover 14-pin injector harness connector.
6. Inspect the rear fuel injector harness 14-pin injector connectors for bent or spread pins; inspect the connector seal for damage (signs of water or oil intrusion).
 - a. If water or oil intrusion, bent or spread pins are found, repair as necessary.
 - b. If the connector shows no signs of damage, Go to step 7.

NOTE: DO NOT touch the metal ohmmeter leads with your hands when the measurements are made.

7. Using the appropriate chart below, measure and record the resistance values between the corresponding pins on the valve cover side of the rear fuel injector harness listed below. Are the resistances within range?

Table 17.

Rear Fuel Injector Harness 14-Pin Connector Resistance Chart (Valve Cover Side)				
Injector #4 Needle	Pins 1 and 2	Pins 1 and 8	Pin 2 and ground	Pin 8 and ground
	1.3 to 2.5Ω*	Greater than 100kΩ*	Greater than 100kΩ*	Greater than 100kΩ*
	Ω	Ω	Ω	Ω
Injector #5 Needle	Pins 1 and 3	Pins 1 and 9	Pin 3 and ground	Pin 9 and ground
	1.3 to 2.5Ω*	Greater than 100kΩ*	Greater than 100kΩ*	Greater than 100kΩ*
	Ω	Ω	Ω	Ω
Injector #6 Needle	Pins 1 and 4	Pins 1 and 12	Pin 4 and ground	Pin 12 and ground
	1.3 to 2.5Ω*	Greater than 100kΩ*	Greater than 100kΩ*	Greater than 100kΩ*
	Ω	Ω	Ω	Ω
* = acceptable resistance				

VALVE COVER SIDE

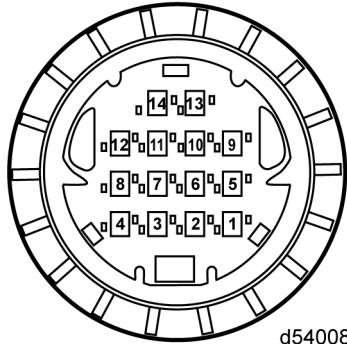

d540083

Table 18.

Rear Fuel Injector Harness 14-Pin Connector Resistance Chart (Using J-48671-10 Injector Breakout Box)				
Note: Ensure J-48671-10 ground strap is connected to cylinder head.				
Injector #4 Needle	Pins 3 and 4	Pins 2 and 3	Pin 2 and ground	Pin 3 and ground
	1.3 to 2.5Ω*	Greater than 100kΩ*	Greater than 100kΩ*	Greater than 100kΩ*
	Ω	Ω	Ω	Ω
Injector #5 Needle	Pins 3 and 4	Pins 2 and 3	Pin 2 and ground	Pin 3 and ground
	1.3 to 2.5Ω*	Greater than 100kΩ*	Greater than 100kΩ*	Greater than 100kΩ*
	Ω	Ω	Ω	Ω
Injector #6 Needle	Pins 3 and 4	Pins 2 and 3	Pin 2 and ground	Pin 3 and ground
	1.3 to 2.5Ω*	Greater than 100kΩ*	Greater than 100kΩ*	Greater than 100kΩ*
	Ω	Ω	Ω	Ω
* = acceptable resistance				

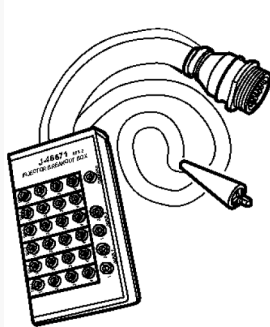

d580085

- a. Yes; Go to step 11.
- b. No; Go to step 8.

8. Remove the rocker cover. Refer to section "Removal of the Rocker Cover".
9. Remove the rear fuel injector harness from the engine.
Refer to section "Removal of the Two-Piece Fuel Injector Wiring Harness - Three-Filter System".
Refer to section "Removal of the Two-Piece Fuel Injector Wiring Harness - Two-Filter System".

NOTE: DO NOT touch the metal ohmmeter leads with your hands when the measurements are made.

10. Using the chart below, measure and record the resistance values between the injector pins listed below. Are the resistances within range?

Table 19.

Injector Needle Resistance Chart (Injector Harness must be removed from engine)					
Injector #4 Needle	Pins 3 and 4	Pins 2 and 3	Pin 2 and ground	Pin 3 and ground	
	2.0Ω or less*	Greater than 100kΩ*	Greater than 100kΩ*	Greater than 100kΩ*	
	Ω	Ω	Ω	Ω	
Injector #5 Needle	Pins 3 and 4	Pins 2 and 3	Pin 2 and ground	Pin 3 and ground	
	2.0Ω or less*	Greater than 100kΩ*	Greater than 100kΩ*	Greater than 100kΩ*	
	Ω	Ω	Ω	Ω	
Injector #6 Needle	Pins 3 and 4	Pins 2 and 3	Pin 2 and ground	Pin 3 and ground	
	2.0Ω or less*	Greater than 100kΩ*	Greater than 100kΩ*	Greater than 100kΩ*	
	Ω	Ω	Ω	Ω	
* = acceptable resistance					

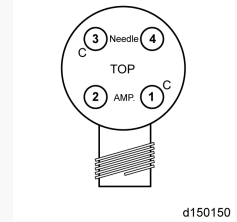

- a. Yes; replace the rear fuel injector harness.
Refer to section "Removal of the Two-Piece Fuel Injector Wiring Harness - Three-Filter System".
Refer to section "Removal of the Two-Piece Fuel Injector Wiring Harness - Two-Filter System".
 - b. No; replace the injector with the out-of-range resistance.
Refer to section "Removal of the Fuel Injector - Three-Filter System".
Refer to section "Removal of the Fuel Injector - Two-Filter System".
11. Disconnect the MCM 120-pin connector.
12. Inspect the MCM 120-pin connector and 120-pin harness connector for signs of corrosion, spread, unseated (pushed out) or damaged pins, connector seal for damage (signs of water or oil intrusion) or signs of wire damage.
- a. If signs of damage are found, repair as necessary. Verify repairs.
 - b. If no signs of damage, Go to step 13.

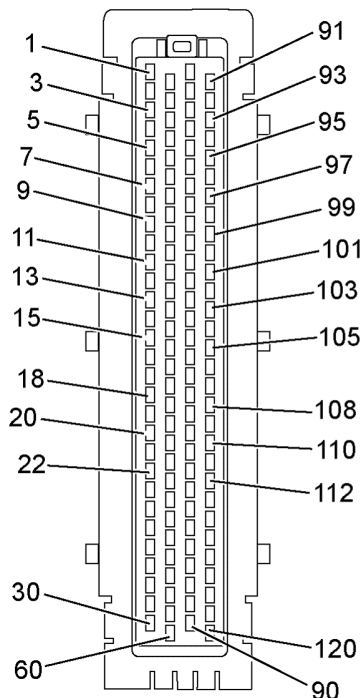

ENGINE HARNESS SIDE

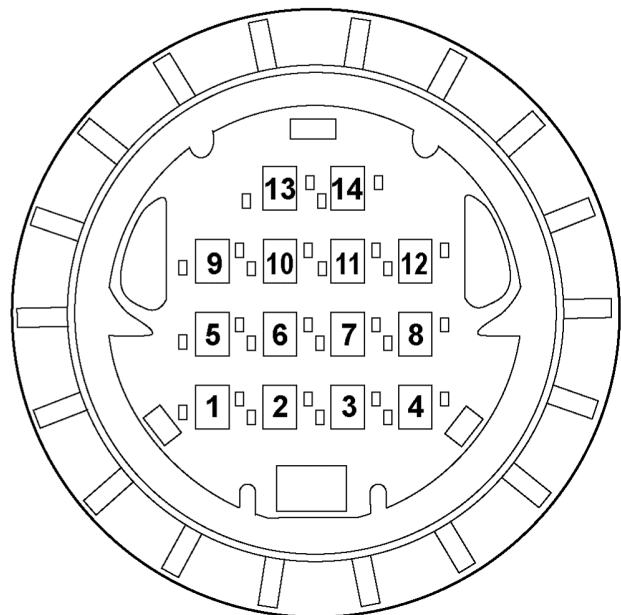

d540080

NOTE: DO NOT touch the metal ohmmeter leads with your hands when the measurements are made.

13. Using the chart below, measure and record the resistance values between the engine side of the rear valve cover 14-pin connector and the MCM 120-pin connector. Are the resistances within range?

Table 20.

Engine Harness Injector Circuit Resistance Table				
Rear Engine Side Valve Cover 14-pin connector #	MCM 120-Pin Harness Connector	Acceptable Resistance 1 Ω or less	Rear Engine Side Valve Cover 14 pin connector #	Acceptable Resistance 1K Ω or greater
1	19	Ω	1 and ground	Ω
2	16	Ω	2 and ground	Ω
3	20	Ω	3 and ground	Ω
4	18	Ω	4 and ground	Ω

- a. Yes; Go to step 14.
- b. No; repair the engine side harness. Verify repairs.

NOTE: The use of extension harness J49120 will ease installation of test MCM.

14. Install a test MCM.
15. Reconnect all connections and start engine. Bring to operating temperature of 71°C (160°F). Road test the vehicle for 30 minutes. Does fault become active?
 - a. Yes; repeat all steps. If results are the same, retain a log file of active fault and the measured resistance values recorded in this procedure and contact the Customer Support Center at 800-445-1980 for further instructions.
 - b. No; Go to step 16.
16. Install original MCM. Bring to operating temperature of 71°C (160°F). Road test the vehicle for 30 minutes. Does fault become active?
 - a. Yes; retain log file of active fault. Replace the MCM. Refer to section "Removal of the Motor Control Module".
 - b. No; release vehicle.

6 SPN 655/FMI 6 - EPA10 - GHG14

Injector Cylinder #5 Needle Control Valve Shorted Circuit

Table 21.

SPN 655/FMI 6	
Description	Injector Cylinder #5 Needle Control Valve Shorted Circuit
Monitored Parameter	Injector Cylinder #5 Needle Control Valve
Typical Enabling Conditions	Engine rpm = idle or higher
Monitor Sequence	None
Execution Frequency	Continuous when enabling conditions met
Typical Duration	Two Seconds
Dash Lamps	MIL, CEL
Engine Reaction	Derate 25%
Verification	Engine Idle (one minute)

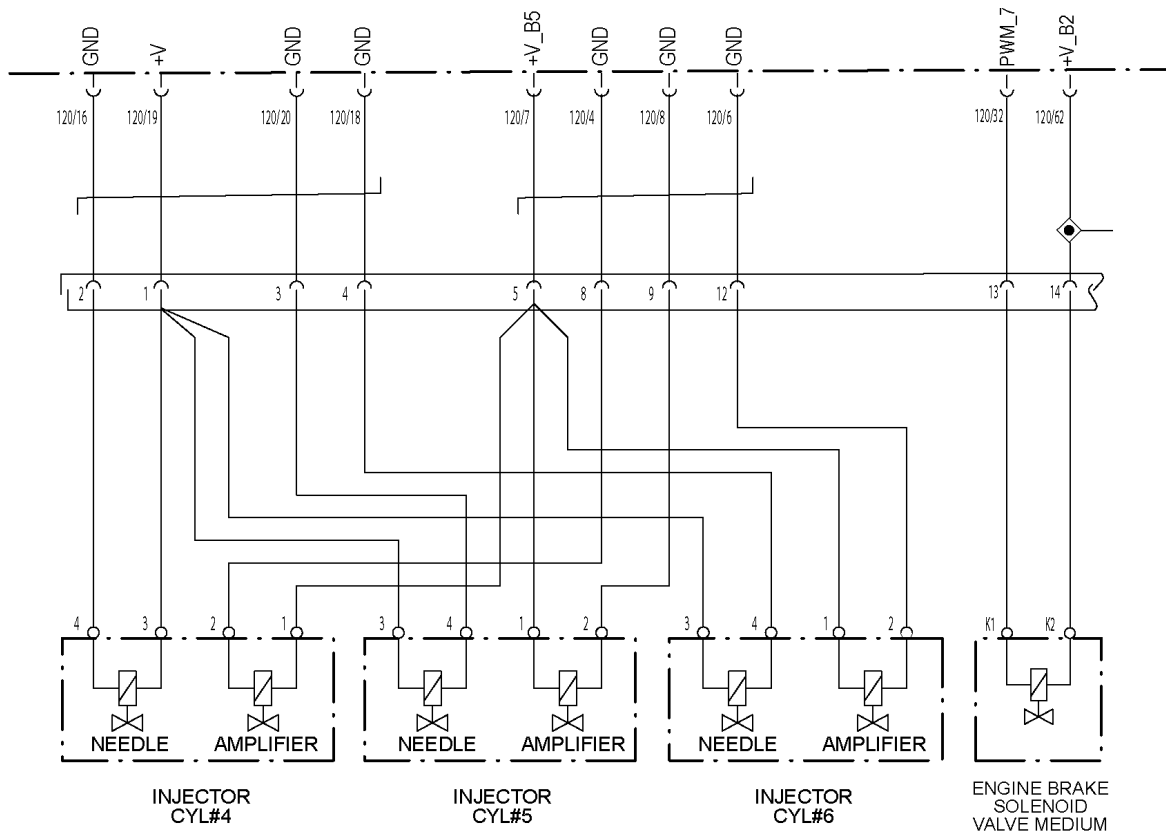

d150022

Check as follows:

NOTE: Submit completed diagnostics with warranty claim.

NOTE: Injector chart PDF available on DDCSN/SUPPORT/SPECIALIZED SERVICE.

1. Check for multiple codes. Using DiagnosticLink[®], retain log file of active fault and clear codes (code active for one key cycle).

- a. If SPN fault code 168 or 723/FMI any is present, service those faults first.
 - b. If SPN fault code 168 or 723/FMI any is NOT present, Go to step 2.
2. Check the warranty claim history. Check with driver. Is this the first occurrence of this fault within the last 30 days?
 - a. Yes; Go to step 3.
 - b. No; complete diagnostics, retain a log file of active fault and the measured resistance values recorded in this procedure and contact the Customer Support Center at 800-445-1980.

WARNING: ENGINE EXHAUST

To avoid injury from inhaling engine exhaust, always operate the engine in a well-ventilated area. Engine exhaust is toxic.

WARNING: PERSONAL INJURY

To avoid injury before starting and running the engine, ensure the vehicle is parked on a level surface, parking brake is set, and the wheels are blocked.

3. Start and warm the engine until the coolant temperature is above 71°C (160°F).
4. Turn the engine OFF.
5. Disconnect the rear rocker cover 14-pin injector harness connector.
6. Inspect the rear fuel injector harness 14-pin injector connectors for bent or spread pins; inspect the connector seal for damage (signs of water or oil intrusion).
 - a. If water or oil intrusion, bent or spread pins are found, repair as necessary.
 - b. If the connector shows no signs of damage, Go to step 7.

NOTE: DO NOT touch the metal ohmmeter leads with your hands when the measurements are made.

7. Using the appropriate chart below, measure and record the resistance values between the corresponding pins on the valve cover side of the rear fuel injector harness listed below. Are the resistances within range?

Table 22.

Rear Fuel Injector Harness 14-Pin Connector Resistance Chart (Valve Cover Side)				
Injector #4 Needle	Pins 1 and 2	Pins 1 and 8	Pin 2 and ground	Pin 8 and ground
	1.3 to 2.5Ω*	Greater than 100kΩ*	Greater than 100kΩ*	Greater than 100kΩ*
	Ω	Ω	Ω	Ω
Injector #5 Needle	Pins 1 and 3	Pins 1 and 9	Pin 3 and ground	Pin 9 and ground
	1.3 to 2.5Ω*	Greater than 100kΩ*	Greater than 100kΩ*	Greater than 100kΩ*
	Ω	Ω	Ω	Ω
Injector #6 Needle	Pins 1 and 4	Pins 1 and 12	Pin 4 and ground	Pin 12 and ground
	1.3 to 2.5Ω*	Greater than 100kΩ*	Greater than 100kΩ*	Greater than 100kΩ*
	Ω	Ω	Ω	Ω
* = acceptable resistance				

VALVE COVER SIDE

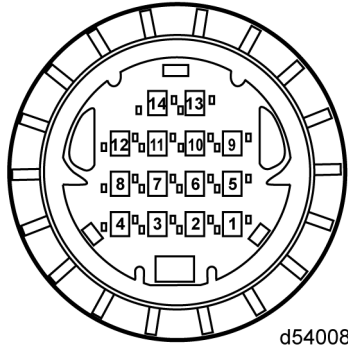

d540083

Table 23.

Rear Fuel Injector Harness 14-Pin Connector Resistance Chart (Using J-48671-10 Injector Breakout Box)				
Note: Ensure J-48671-10 ground strap is connected to cylinder head.				
Injector #4 Needle	Pins 3 and 4	Pins 2 and 3	Pin 2 and ground	Pin 3 and ground
	1.3 to 2.5Ω*	Greater than 100kΩ*	Greater than 100kΩ*	Greater than 100kΩ*
	Ω	Ω	Ω	Ω
Injector #5 Needle	Pins 3 and 4	Pins 2 and 3	Pin 2 and ground	Pin 3 and ground
	1.3 to 2.5Ω*	Greater than 100kΩ*	Greater than 100kΩ*	Greater than 100kΩ*
	Ω	Ω	Ω	Ω
Injector #6 Needle	Pins 3 and 4	Pins 2 and 3	Pin 2 and ground	Pin 3 and ground
	1.3 to 2.5Ω*	Greater than 100kΩ*	Greater than 100kΩ*	Greater than 100kΩ*
	Ω	Ω	Ω	Ω
* = acceptable resistance				

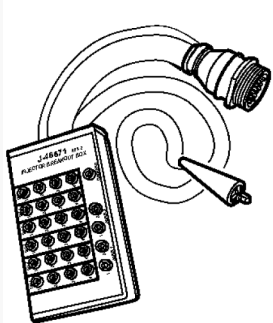

d580085

- a. Yes; Go to step 11.
- b. No; Go to step 8.

8. Remove the rocker cover. Refer to section "Removal of the Rocker Cover".
9. Remove the rear fuel injector harness from the engine.
Refer to section "Removal of the Two-Piece Fuel Injector Wiring Harness - Three-Filter System".
Refer to section "Removal of the Two-Piece Fuel Injector Wiring Harness - Two-Filter System".

NOTE: DO NOT touch the metal ohmmeter leads with your hands when the measurements are made.

10. Using the chart below, measure and record the resistance values between the injector pins listed below. Are the resistances within range?

Table 24.

Injector Needle Resistance Chart (Injector Harness must be removed from engine)				
Injector #4 Needle	Pins 3 and 4	Pins 2 and 3	Pin 2 and ground	Pin 3 and ground
	2.0Ω or less*	Greater than 100kΩ*	Greater than 100kΩ*	Greater than 100kΩ*
	Ω	Ω	Ω	Ω
Injector #5 Needle	Pins 3 and 4	Pins 2 and 3	Pin 2 and ground	Pin 3 and ground
	2.0Ω or less*	Greater than 100kΩ*	Greater than 100kΩ*	Greater than 100kΩ*
	Ω	Ω	Ω	Ω
Injector #6 Needle	Pins 3 and 4	Pins 2 and 3	Pin 2 and ground	Pin 3 and ground
	2.0Ω or less*	Greater than 100kΩ*	Greater than 100kΩ*	Greater than 100kΩ*
	Ω	Ω	Ω	Ω
* = acceptable resistance				

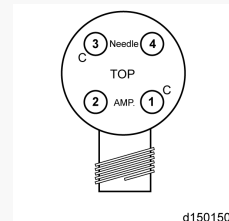

- a. Yes; replace the rear fuel injector harness.
Refer to section "Removal of the Two-Piece Fuel Injector Wiring Harness - Three-Filter System".
Refer to section "Removal of the Two-Piece Fuel Injector Wiring Harness - Two-Filter System".
 - b. No; replace the injector with the out-of-range resistance.
Refer to section "Removal of the Fuel Injector - Three-Filter System".
Refer to section "Removal of the Fuel Injector - Two-Filter System".
11. Disconnect the Motor Control Module (MCM) 120-pin connector.
 12. Inspect the MCM 120-pin connector and 120-pin harness connector for signs of corrosion, spread, unseated (pushed out) or damaged pins, connector seal for damage (signs of water or oil intrusion) or signs of wire damage.
 - a. If signs of damage are found, repair as necessary. Verify repairs.
 - b. If no signs of damage, Go to step 13.

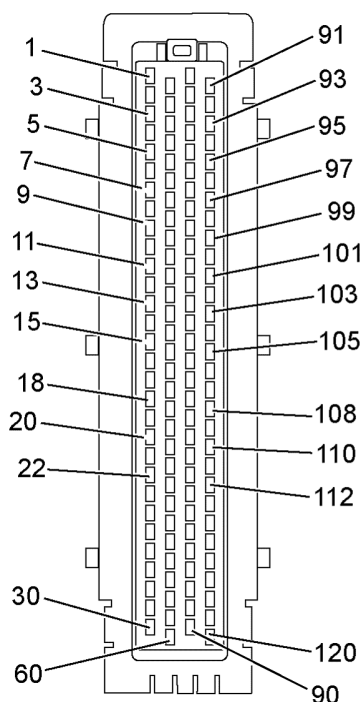

ENGINE HARNESS SIDE

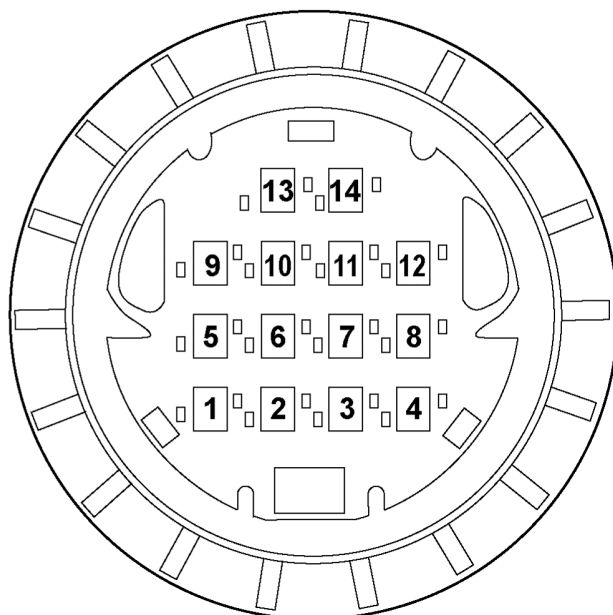

d540080

NOTE: DO NOT touch the metal ohmmeter leads with your hands when the measurements are made.

13. Using the chart below, measure and record the resistance values between the engine side of the rear valve cover 14-pin connector and the MCM 120-pin connector. Are the resistances within range?

Table 25.

Engine Harness Injector Circuit Resistance Table				
Rear Engine Side Valve Cover 14-pin connector #	MCM 120-Pin Harness Connector	Acceptable Resistance 1Ω or less	Rear Engine Side Valve Cover 14 pin connector #	Acceptable Resistance 1KΩ or greater
1	19	Ω	1 and ground	Ω
2	16	Ω	2 and ground	Ω
3	20	Ω	3 and ground	Ω
4	18	Ω	4 and ground	Ω

- a. Yes; Go to step 14.
b. No; repair the engine side harness.

NOTE: The use of extension harness J-49120 will ease installation of test MCM.

14. Install a test MCM.
15. Reconnect all connections and start engine. Bring to operating temperature of 71°C (160°F). Road test the vehicle for 30 minutes. Does fault become active?
a. Yes; repeat all steps. If results are the same, retain a log file of active fault and the measured resistance values recorded in this procedure and contact the Customer Support Center at 800-445-1980 for further instructions.
b. No; Go to step 16.
16. Install original MCM. Bring to operating temperature of 71°C (160°F). Road test the vehicle for 30 minutes. Does fault become active?
a. Yes; retain log file of active fault. Replace the MCM. Refer to section "Removal of the Motor Control Module".
b. No; release vehicle.

7 SPN 656/FMI 6 - EPA10 - GHG14

Injector Cylinder #6 Needle Control Valve Shorted Circuit

Table 26.

SPN 656/FMI 6	
Description	Injector Cylinder #6 Needle Control Valve Shorted Circuit
Monitored Parameter	Injector Cylinder #6 Needle Control Valve
Typical Enabling Conditions	Engine rpm = idle or higher
Monitor Sequence	None
Execution Frequency	Continuous when enabling conditions met
Typical Duration	Two Seconds
Dash Lamps	MIL, CEL
Engine Reaction	Derate 25%
Verification	Engine Idle (one minute)

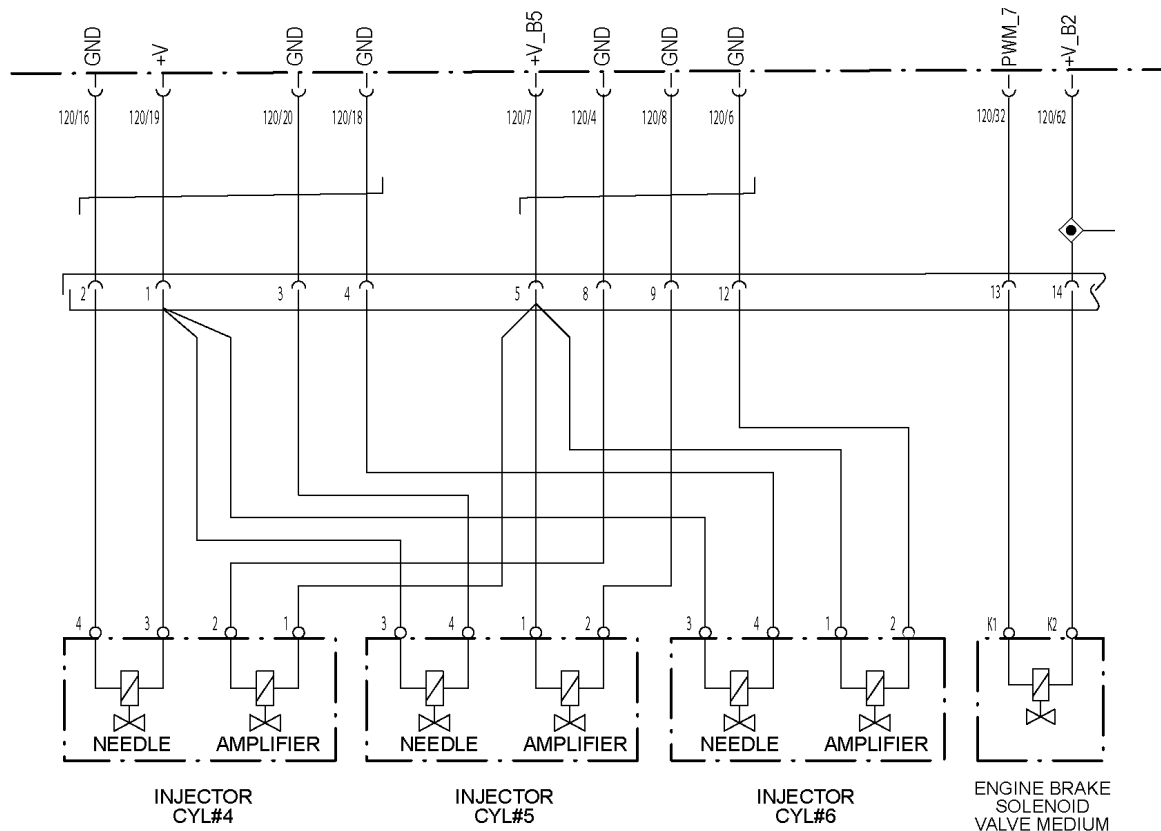

d150022

Check as follows:

NOTE: Submit completed diagnostics with warranty claim.

NOTE: Injector chart PDF available on DDCSN/SUPPORT/SPECIALIZED SERVICE.

1. Check for multiple codes. Using DiagnosticLink[®], retain log file of active fault and clear codes (code active for one key cycle).

- a. If SPN fault code 168 or 723/FMI any is present, service those faults first.
- b. If SPN fault code 168 or 723/FMI any is NOT present, Go to step 2.
- 2. Check the warranty claim history. Check with driver. Is this the first occurrence of this fault within the last 30 days?
 - a. Yes; Go to step 3.
 - b. No; complete diagnostics, retain a log file of active fault and the measured resistance values recorded in this procedure and contact the Customer Support Center at 800-445-1980.
- 3. Start and warm the engine until the coolant temperature is above 71°C (160°F).
- 4. Turn the engine OFF.
- 5. Disconnect the rear fuel injector harness 14-pin connector.
- 6. Inspect the rear fuel injector harness 14-pin injector connectors for bent or spread pins; inspect the connector seal for damage (signs of water or oil intrusion).
 - a. If water or oil intrusion, bent or spread pins are found, repair as necessary.
 - b. If the connector shows no signs of damage, Go to step 7.

NOTE: DO NOT touch the metal ohmmeter leads with your hands when the measurements are made.

- 7. Using the appropriate chart below, measure and record the resistance values between the corresponding pins on the valve cover side of the rear fuel injector harness listed below. Are the resistances within range?

Table 27.

Rear Fuel Injector Harness 14-Pin Connector Resistance Chart (Valve Cover Side)				
Injector #4 Needle	Pins 1 and 2	Pins 1 and 8	Pin 2 and ground	Pin 8 and ground
	1.3 to 2.5Ω*	Greater than 100kΩ*	Greater than 100kΩ*	Greater than 100kΩ*
	Ω	Ω	Ω	Ω
Injector #5 Needle	Pins 1 and 3	Pins 1 and 9	Pin 3 and ground	Pin 9 and ground
	1.3 to 2.5Ω*	Greater than 100kΩ*	Greater than 100kΩ*	Greater than 100kΩ*
	Ω	Ω	Ω	Ω
Injector #6 Needle	Pins 1 and 4	Pins 1 and 12	Pin 4 and ground	Pin 12 and ground
	1.3 to 2.5Ω*	Greater than 100kΩ*	Greater than 100kΩ*	Greater than 100kΩ*
	Ω	Ω	Ω	Ω
* = acceptable resistance				

VALVE COVER SIDE

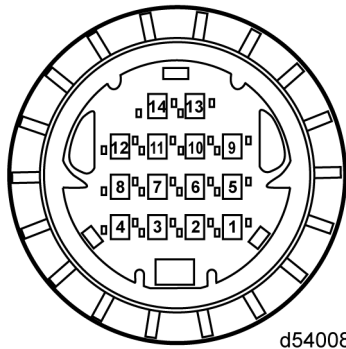

d540083

Table 28.

Rear Fuel Injector Harness 14-Pin Connector Resistance Chart (Using J-48671-10 Injector Breakout Box)				
Note: Ensure J-48671-10 ground strap is connected to cylinder head.				
Injector #4 Needle	Pins 3 and 4	Pins 2 and 3	Pin 2 and ground	Pin 3 and ground
	1.3 to 2.5Ω*	Greater than 100kΩ*	Greater than 100kΩ*	Greater than 100kΩ*
	Ω	Ω	Ω	Ω
Injector #5 Needle	Pins 3 and 4	Pins 2 and 3	Pin 2 and ground	Pin 3 and ground
	1.3 to 2.5Ω*	Greater than 100kΩ*	Greater than 100kΩ*	Greater than 100kΩ*
	Ω	Ω	Ω	Ω
Injector #6 Needle	Pins 3 and 4	Pins 2 and 3	Pin 2 and ground	Pin 3 and ground
	1.3 to 2.5Ω*	Greater than 100kΩ*	Greater than 100kΩ*	Greater than 100kΩ*
	Ω	Ω	Ω	Ω
* = acceptable resistance				

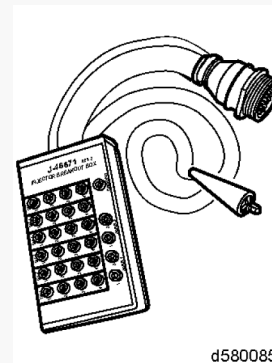

- a. Yes; Go to step 11.
 - b. No; Go to step 8.
8. Remove the rocker cover. Refer to section "Removal of the Rocker Cover".
 9. Remove the rear fuel injector harness from the engine.
Refer to section "Removal of the Two-Piece Fuel Injector Wiring Harness - Three-Filter System".
Refer to section "Removal of the Two-Piece Fuel Injector Wiring Harness - Two-Filter System".

NOTE: DO NOT touch the metal ohmmeter leads with your hands when the measurements are made.

10. Using the chart below, measure and record the resistance values between the injector pins listed below. Are the resistances within range?

Table 29.

Injector Needle Resistance Chart (Injector Harness must be removed from engine)				
Injector #4 Needle	Pins 3 and 4	Pins 2 and 3	Pin 2 and ground	Pin 3 and ground
	2.0Ω or less*	Greater than 100kΩ*	Greater than 100kΩ*	Greater than 100kΩ*
	Ω	Ω	Ω	Ω
Injector #5 Needle	Pins 3 and 4	Pins 2 and 3	Pin 2 and ground	Pin 3 and ground
	2.0Ω or less*	Greater than 100kΩ*	Greater than 100kΩ*	Greater than 100kΩ*
	Ω	Ω	Ω	Ω
Injector #6 Needle	Pins 3 and 4	Pins 2 and 3	Pin 2 and ground	Pin 3 and ground
	2.0Ω or less*	Greater than 100kΩ*	Greater than 100kΩ*	Greater than 100kΩ*
	Ω	Ω	Ω	Ω
* = acceptable resistance				

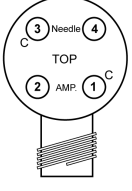

d150150

- a. Yes; replace the rear fuel injector harness.
Refer to section "Removal of the Two-Piece Fuel Injector Wiring Harness - Three-Filter System".
Refer to section "Removal of the Two-Piece Fuel Injector Wiring Harness - Two-Filter System".
- b. No; replace the injector with the out-of-range resistance.
Refer to section "Removal of the Fuel Injector - Three-Filter System".
Refer to section "Removal of the Fuel Injector - Two-Filter System".

11. Disconnect the Motor Control Module (MCM) 120-pin connector.

NOTE: DO NOT touch the metal ohmmeter leads with your hands when the measurements are made.

12. Inspect the MCM 120-pin connector and 120-pin harness connector for signs of corrosion, spread, unseated (pushed out) or damaged pins, connector seal for damage (signs of water or oil intrusion) or signs of wire damage.

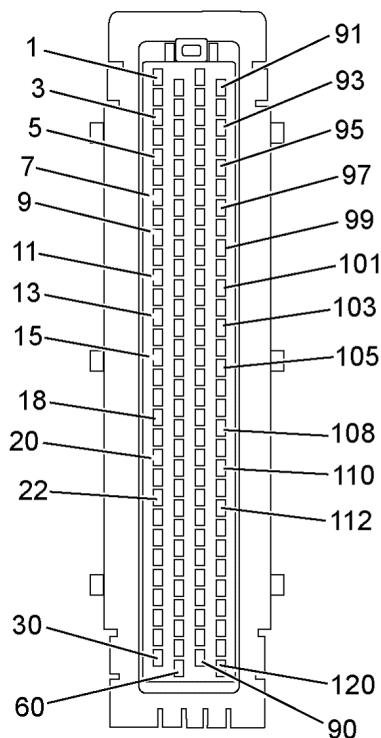

ENGINE HARNESS SIDE

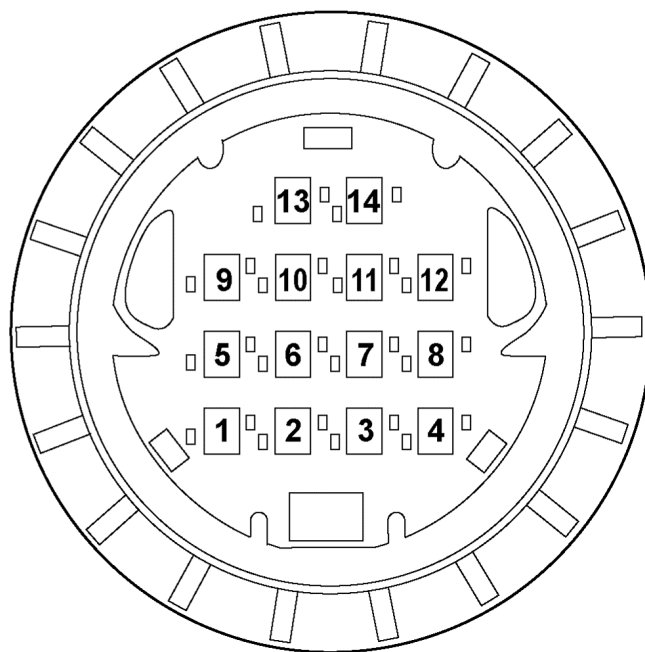

d540080

- a. If signs of damage are found, repair as necessary. Verify repairs.
- b. If no signs of damage, Go to step 13.

NOTE: DO NOT touch the metal ohmmeter leads with your hands when the measurements are made.

13. Using the chart below, measure and record the resistance values between the engine side of the rear valve cover 14-pin connector and the MCM 120-pin connector. Are the resistances within range?

Table 30.

Engine Harness Injector Circuit Resistance Table				
Rear Engine Side Valve Cover 14-pin connector #	MCM 120-Pin Harness Connector	Acceptable Resistance 1Ω or less	Rear Engine Side Valve Cover 14 pin connector #	Acceptable Resistance 1KΩ or greater
1	19	Ω	1 and ground	Ω
2	16	Ω	2 and ground	Ω
3	20	Ω	3 and ground	Ω
4	18	Ω	4 and ground	Ω

- a. Yes; Go to step 14.
- b. No; repair the engine side harness.

NOTE: The use of extension harness J-49120 will ease installation of test MCM.

14. Install a test MCM.
15. Reconnect all connections and start engine. Bring to operating temperature of 71°C (160°F). Road test the vehicle for 30 minutes. Does fault become active?
 - a. Yes; repeat all steps. If results are the same, retain a log file of active fault and the measured resistance values recorded in this procedure and contact the Customer Support Center at 800-445-1980 for further instructions.
 - b. No; Go to step 16.

16. Install original MCM. Bring to operating temperature of 71°C (160°F). Road test the vehicle for 30 minutes. Does fault become active?
 - a. Yes; retain log file of active fault. Replace the MCM. Refer to section "Removal of the Motor Control Module".
 - b. No; release vehicle.