

1 5 08-15



Service Information Bulletin

SUBJECT	DATE
SPN 625 (MCM)(EPA10;GHG14)	May 2015

Additions, Revisions, or Updates

Publication Number / Title	Platform	Section Title	Change
DDC-SVC-MAN-0084 DDC-SVC-MAN-S084	DD Platform	SPN 625 /FMI 9 - EPA10 -GHG14	The diagnostic procedure has been updated, the wiring diagram has been changed and connector graphics have been added with colors for pin identification.

DiagnosticLink users: Please update the troubleshooting guides in DiagnosticLink with this newest version. To update the tool troubleshooting guide, open DiagnosticLink and from the Help - Troubleshooting Guides menu, select the appropriate troubleshooting manual, then click Update.



13400 Outer Drive, West, Detroit, Michigan 48239-4001
Telephone: 313-592-5000
www.demanddetroit.com

2 SPN 625/FMI 9 - EPA10 - GHG14

Aftertreatment Control Module PT-CAN DM1 Message Not Received or has Stopped Arriving

Table 1.

SPN 625/FMI 9	
Description	Aftertreatment Control Module (ACM) Message Not Received or has Stopped Arriving.
Monitored Parameter	CAN Communication
Typical Enabling Conditions	Always Enabled
Monitor Sequence	None
Execution Frequency	Always Enabled
Typical Duration	2 Seconds
Dash Lamps	MIL, CEL
Engine Reaction	Derate 25%
Verification	Ignition On

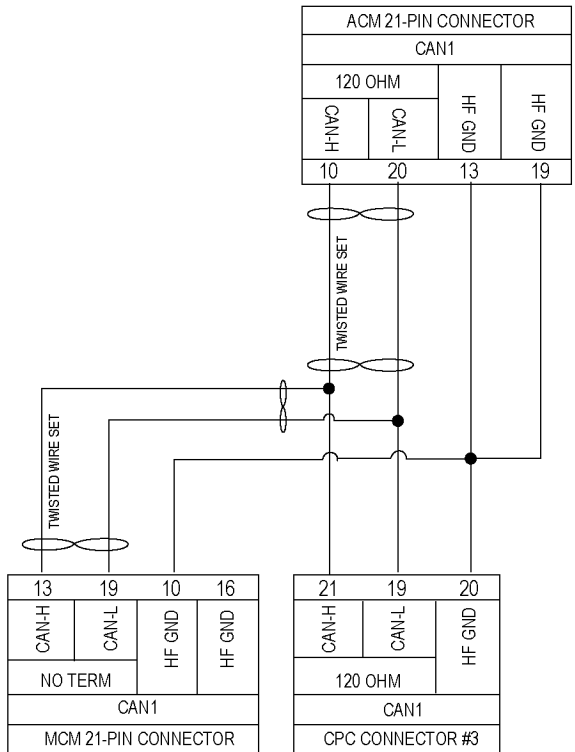

d150235

1. Connect DiagnosticLink[®].
2. Check for multiple fault codes. Are fault codes SPN 168/ FMI present in any of the modules?
 - a. Yes; diagnose the other fault codes first.
 - b. No; Go to step 3.
3. Has the Aftertreatment Control Module (ACM), Motor Control Module (MCM) or Common Powertrain Controller (CPC) been recently programmed?
 - a. Yes; clear the fault codes and cycle the ignition. If the fault code returns, Go to step 4.
 - b. No; Go to step 4.
4. Turn the ignition OFF.

5. Disconnect and inspect the ACM 21-pin electrical harness connector. Are there any damaged pins or corrosion present in the connector?
 - a. Yes; repair the connector as necessary.
 - b. No; Go to step 6.
6. Measure the battery voltage at the batteries and record the voltage.



CAUTION: ELECTRICAL SHOCK

To avoid injury from electrical shock, use care when connecting battery cables. The magnetic switch studs are at battery voltage.

7. Turn the ignition ON (key ON, engine OFF).
8. Measure the voltage between pins 11, 12, 14, 15, 18 and ground of the 21-pin ACM connector, harness side. Is the voltage measurement on pins 11, 12, 14, 15, and 18 within one volt of the battery voltage?

Table 2.

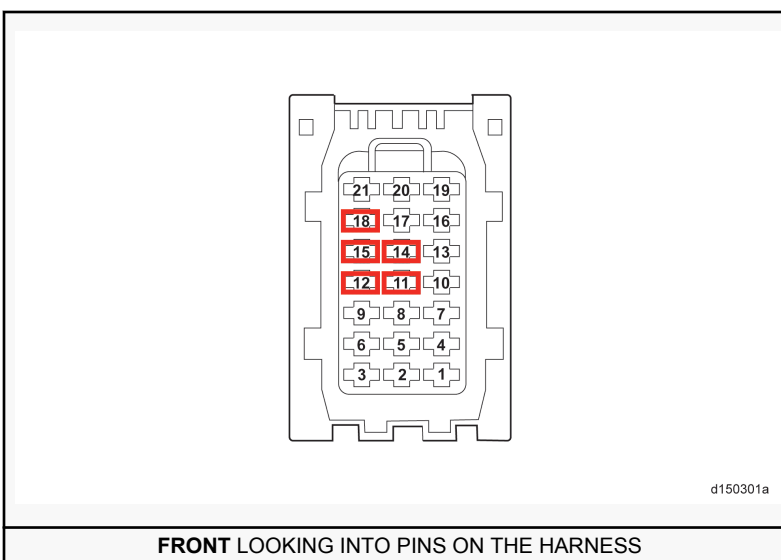

- a. Yes; Go to step 9.
 - b. No; repair the power circuits to pins 11, 12, 14, 15, and 18 of the 21-pin ACM connector.
9. Measure resistance between pins 3, 5, 6, 8, and 9 of the 21-pin ACM connector, harness side and ground. Are the resistances less than five ohms for each pin?

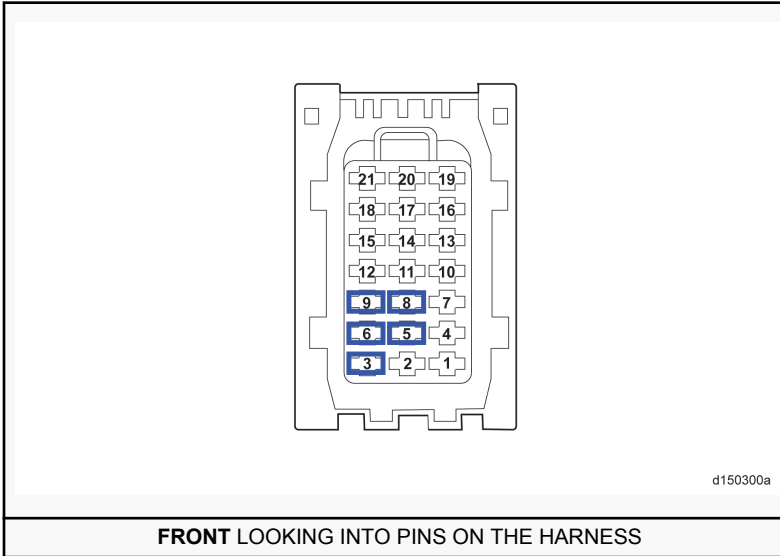
Table 3.

- a. Yes; Go to step 10.
 - b. No; repair the circuit in question.
10. Turn the ignition OFF.
 11. Measure resistance between pin 10 and pin 20 on the ACM connector, components side. Is the resistance between 115 and 125 ohms?

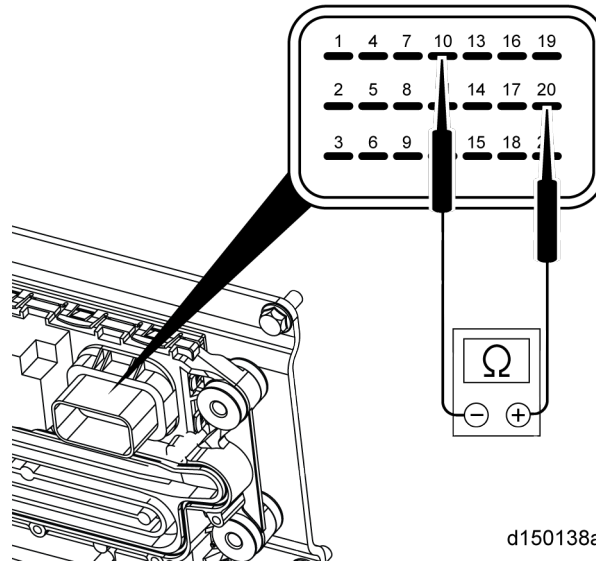

- a. Yes; Go to step 12.
 - b. No; replace the ACM. Refer to section "Removal of the Aftertreatment Control Module"
12. Measure resistance between pin 10 and pin 20 on the ACM connector, harness side. Is the resistance between 115 and 125 ohms?

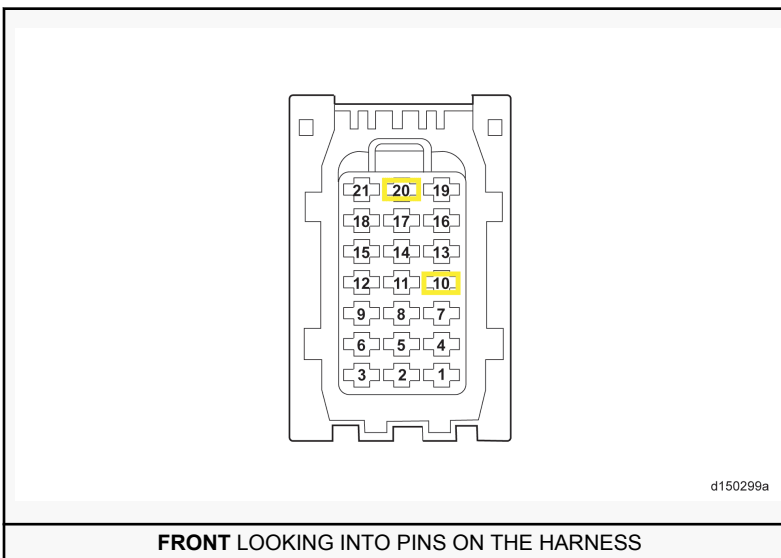
Table 4.

- a. Yes; replace the ACM. Refer to section "Removal of the Aftertreatment Control Module"
- b. No; repair the CAN circuits to pins 10 and 20 of the ACM 21-pin connector, harness side.