

1 5 03-15



## Service Information Bulletin

SUBJECT	DATE
DD13 Exhaust Gas Recirculation Valve Actuator	May 2015

### Additions, Revisions, or Updates

Publication Number / Title	Platform	Section Title	Change
DDC-SVC-MAN-0083	DD Platform	Removal of the DD13 Exhaust Gas Recirculation Valve Actuator	New Note, Notices, and several steps have been updated.
		Installation of the DD13 Exhaust Gas Recirculation Valve Actuator	



13400 Outer Drive, West, Detroit, Michigan 48239-4001  
 Telephone: 313-592-5000  
[www.demanddetroit.com](http://www.demanddetroit.com)

## 2 Removal of the DD13 Exhaust Gas Recirculation Valve Actuator

Remove as follows:

**NOTICE:** The Exhaust Gas Recirculation (EGR) valve actuator shaft must be held still using a wrench when removing or installing the actuator lever or pull rod clamping nuts to avoid damage to the EGR valve actuator internal end stops.

1. Shut off the engine, apply the parking brake, chock the wheels, and perform any other applicable safety steps.
2. Drain the coolant. Refer to section "Cooling System Drain Procedure".
3. Remove the EGR valve actuator pull rod clamping nut and remove the pull rod from the actuator.

**NOTICE:** To prevent damage to the coolant inlet and outlet lines, hold the coolant line fittings with a wrench during line removal.

**NOTE:** If replacing the EGR valve actuator, remove the EGR actuator valve lever. Refer to section "Removal of the Exhaust Gas Recirculation Actuator Lever".

4. Remove the coolant line from the EGR valve actuator and cylinder block.
5. Remove the coolant line from the EGR valve actuator and water manifold.
6. Disconnect the EGR valve actuator electrical harness connector from the engine electrical harness.

**NOTE:** If replacing the EGR valve actuator, remove the coolant line fittings with sealing rings from the EGR valve actuator.

7. Remove the EGR valve actuator from the cylinder block.
  - For the Delphi actuator, remove three bolts and spacers from EGR valve actuator and remove actuator from the cylinder block.
  - For the Sonceboz actuator, remove the three bolts from the EGR valve actuator and remove actuator from the cylinder block.

### 3 Installation of the DD13 Exhaust Gas Recirculation Valve Actuator

Install as follows:

**NOTICE:** If reusing the original Exhaust Gas Recirculation (EGR) valve actuator bracket bolts, always apply a small amount of copper-based anti-seize compound to the bolts. The original coating will burn off and that makes it necessary to reapply the anti-seize compound.

**NOTICE:** Ensure the bracket and exhaust manifold are at ambient temperature when the actuator bracket bolts are torqued.

**NOTICE:** Do not turn on the ignition power until all of the installation steps are completed.

**NOTE:** If replacing the EGR valve actuator, the coolant line fittings with sealing rings on the EGR valve actuator will be reused from the previous actuator. Install the coolant line fittings with sealing rings. Torque the fittings to 25 N·m (18 lb·ft).

1. Shut off the engine, apply the parking brake, chock the wheels, and perform any other applicable safety steps.
2. Install the EGR valve actuator to cylinder block.
  - For the Delphi actuator, install the EGR valve actuator to cylinder block with the three bolts and two spacers. Torque bolts to 30 N·m (22 lb·ft).
  - For the Sonceboz actuator, install the EGR valve actuator to cylinder block with the three bolts. Torque bolts to 30 N·m (22 lb·ft)

**NOTICE:** The EGR valve actuator shaft must be held still using a wrench when removing or installing the actuator lever or pull rod clamping nuts to avoid damage to the EGR valve actuator internal end stops.

**NOTICE:** If replacing the EGR valve actuator, the EGR actuator valve lever will be reused from the previous actuator. Install the EGR valve actuator lever. Refer to section "Installation of the Exhaust Gas Recirculation Actuator Lever".

3. Install the EGR valve actuator pull rod onto the actuator. Apply a small amount of copper based anti-seize compound to the nut threads and tighten. Make sure that the anti-seize is applied only to the threads and does not get on the pull rod bearings. Torque nut to 20 N·m (15 lb·ft).

**NOTICE:** To prevent damage to the coolant inlet and outlet lines, hold the coolant line fittings with a wrench during line installation.

4. Install the coolant line to the EGR valve actuator and water manifold. Tighten coolant line to EGR valve actuator to 35 N·m (26 lb·ft).
  - For EPA07/10 engines, tighten the coolant fitting to the water manifold to 35 N·m (26 lb·ft).
  - For GHG14 engines, tighten the coolant line banjo bolt to the water manifold to 35 N·m (26 lb·ft).
5. Install the coolant line to the EGR valve actuator and the banjo bolt on cylinder block. Tighten coolant line to EGR valve actuator and the coolant line banjo bolt into the cylinder block to 35 N·m (26 lb·ft).
6. Connect the EGR valve actuator to the engine wiring harness and attach the EGR valve actuator wiring to the points shown below.

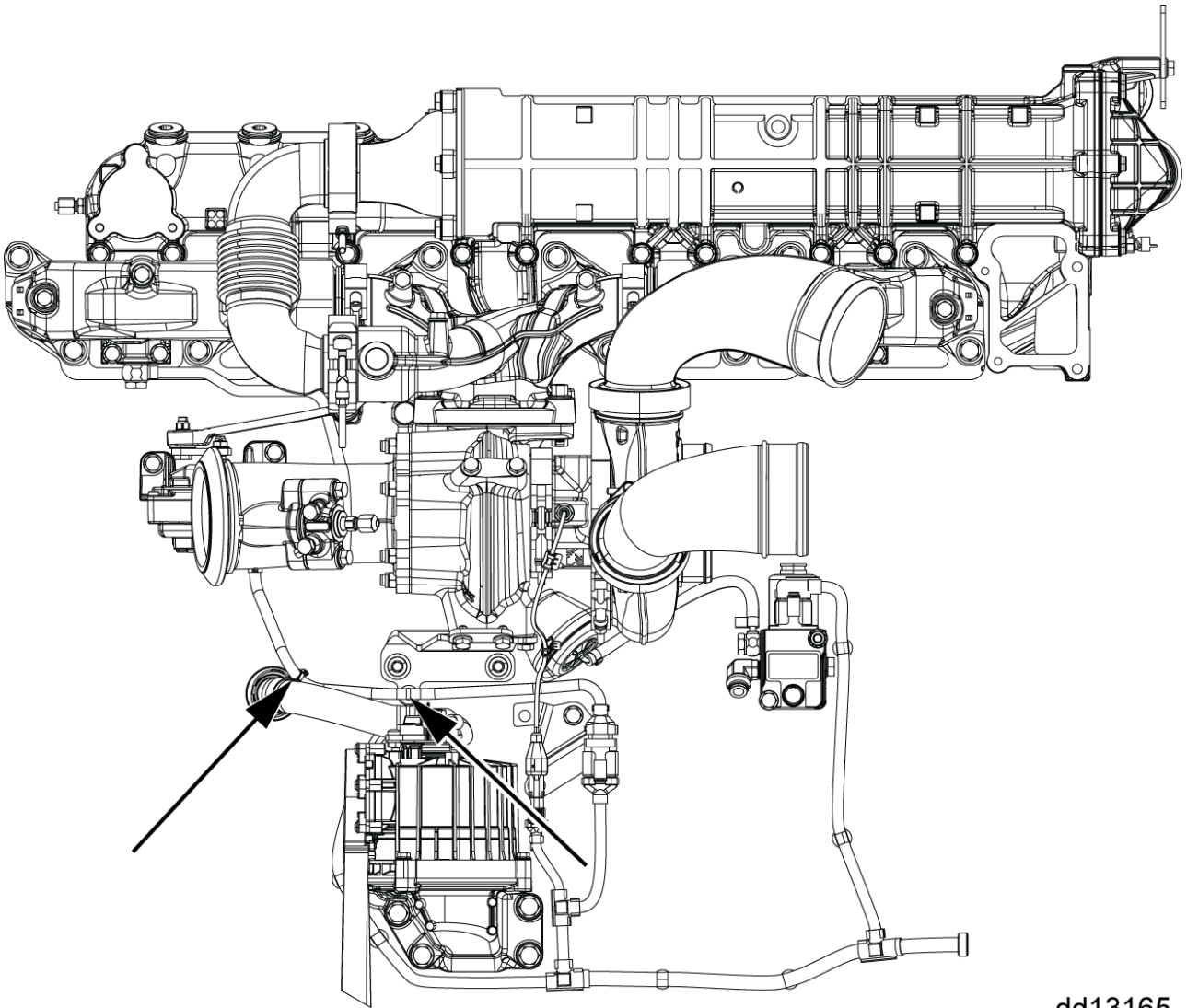

dd13165

7. Fill the coolant system. Refer to section "Cooling System Fill Procedure".
8. For EPA07 engines, turn the ignition key on in order to slow learn the EGR actuator.
9. For EPA10 and newer engines, run the "EGR Actuator Slow Learn" procedure in DiagnosticLink<sup>®</sup>.