

FLA COE
FLB COE
FLD Conventional
Business Class
FLC 112 Conventional

Century Class Conventional
Argosy COE
Cargo
Columbia

122SD and Coronado
> Business Class M2
Cascadia
> 108SD/114SD

Freightliner
Service Bulletin

General Information

On some M2 and 108SD/114SD day cab vehicles, a popping or "oil-canning" noise may be heard from the roof. Typically this is a problem only on vehicles with a tall box-van body mounted directly behind the cab, with no roof deflector or fairing.

The installation of a foam block between the overhead console structure and the roof skin can minimize the noises from the roof. If there is a complaint of the described noises coming from the roof, use the instructions in this bulletin to install the foam block and to add sealant between the roof bows and the roof skin.

Parts

Parts are available through the PDCs. See [Table 1](#).

Parts Required		
Part Number	Description	Qty.
18-68512-000	BLOCK-FOAM, ROOF SUPPORT, M2	1

Table 1, Parts Required

Procedure

1. Park the vehicle on a level surface, shut down the engine, and set the parking brake. Chock the tires.
2. Drain the air tanks.
3. Disconnect the batteries.
4. Remove the passenger seat to allow enough space to remove the headliner from the cab. See the vehicle workshop manual, **Group 91**.
5. Remove all items from the overhead storage bins (if equipped), then pull out the storage bins from the overhead console.
6. Remove the overhead instrument panel surrounds (if equipped).
7. Remove the A-pillar covers, as follows:
 - 7.1 Remove the passenger-side grab handle by removing the screws that attach it to the A-pillar.
 - 7.2 Remove the screw that attaches the top of the passenger-side A-pillar cover to the cab, then remove the A-pillar cover.
 - 7.3 Remove the two screws from the driver-side A-pillar cover, then pull the bottom of the cover to loosen the clip that attaches it to the cab structure.
8. Remove the sun visors, as follows:
 - 8.1 Remove the three screws that attach each sun visor to the overhead console. Remove the sun visors.
 - 8.2 Remove the sun visor inboard retainers.
9. Disconnect the dome light wiring.
10. Remove the coat hooks.
11. Remove the two fir-tree fasteners that attach the center of the headliner to the roof bows.

**Freightliner
Service Bulletin**

FLA COE
FLB COE
FLD Conventional
Business Class
FLC 112 Conventional

Century Class Conventional
Argosy COE
Cargo
Columbia

122SD and Coronado
> Business Class M2
Cascadia
> 108SD/114SD

12. If so equipped, disconnect the air horn lanyard from its anchor point on the headliner and cab roof structure, then push it up through the slot in the headliner.
13. Remove the four fir-tree fasteners that secure the headliner by the windshield, and the two fir-tree fasteners at the rear wall.
14. Pull down the headliner, then disconnect the dome light wiring.
15. Remove the headliner from the cab.
16. Peel the adhesive backing from the foam block, then install the block on top of the overhead console structure, with the adhesive side down. See **Fig. 1**.
17. Check for unfilled gaps between the roof bows and roof skin. If necessary, fill the gaps with Sikaflex®-252, Sikaflex-255, or similar caulking material to prevent noise. See **Fig. 2**.

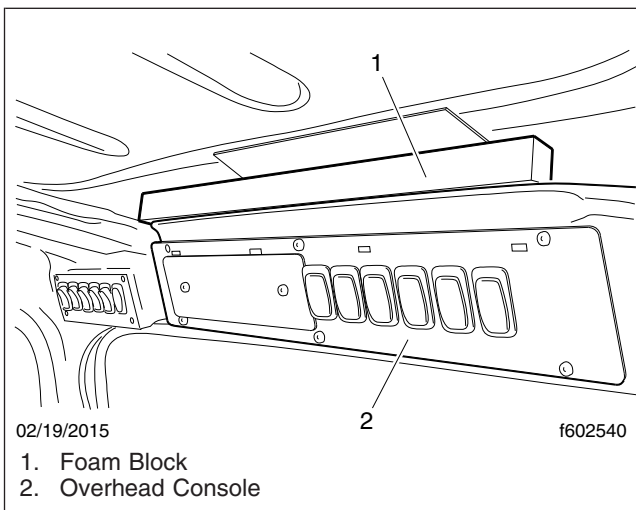

Fig. 1, Foam Block Installed

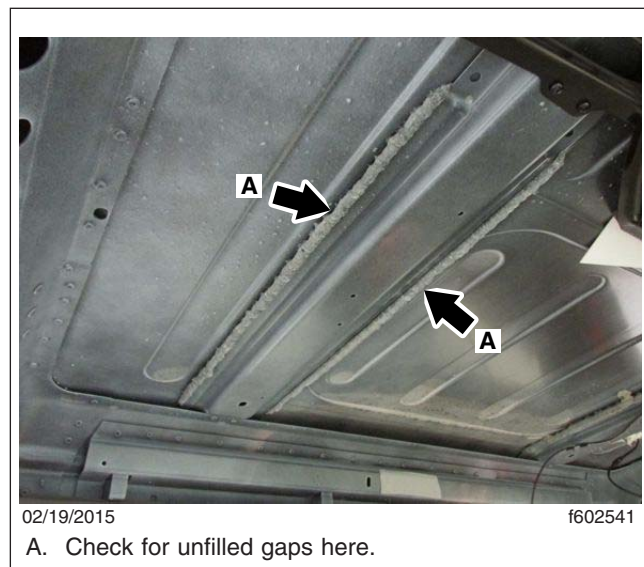

Fig. 2, Roof Bow Inspection

18. With the help of an assistant, position the headliner in place.
19. Using new fir-tree fasteners, secure the headliner by the windshield and the rear wall.
20. Pull the air horn lanyard out through the slot in the headliner, then attach the lanyard to its anchor point on the headliner and cab roof structure.
21. Install the sun visors, as follows:
 - 21.1 Install the sun visor inboard retainers.
 - 21.2 Attach the sun visor outboard brackets to the overhead console.
22. Using new fir-tree fasteners, attach the headliner to the roof bows.
23. Attach the center seat belt anchor (if so equipped) to the rear wall.
24. Install the coat hooks.
25. Connect the wiring to the dome light.
26. Install the overhead instrument panel surrounds (if equipped).

FLA COE
FLB COE
FLD Conventional
Business Class
FLC 112 Conventional

Century Class Conventional
Argosy COE
Cargo
Columbia

122SD and Coronado
> Business Class M2
Cascadia
> 108SD/114SD

**Freightliner
Service Bulletin**

27. Install the storage bins (if equipped) in the overhead console.
28. Install the A-pillar covers, as follows:
 - 28.1 Position the driver-side A-pillar cover on the A-pillar, and secure the lower portion by pushing the fir-tree fastener into the hole on the A-pillar. Secure the upper portion with two screws.
 - 28.2 Position the passenger-side A-pillar cover on the A-pillar, then install a screw through the top hole into the cab structure.
 - 28.3 Install the passenger-side grab handle on the A-pillar.
29. Install the passenger seat. see the vehicle workshop manual, **Group 91**.
30. Connect the batteries.

Warranty

This bulletin is informational only. Warranty does not apply.