

Technical Service Bulletin



46 S4 and S5 squealing from front brakes (PR-1LJ)

46 15 17 2027636/10 July 14, 2015. Supersedes Technical Service Bulletin Group 46 number 15-11 dated June 29, 2015 for reasons listed below.

Model(s)	Year	VIN Range	Vehicle-Specific Equipment
S4	2010 - 2012	All	PR-1LJ
S4	2013	000001 - 083991	PR-1LJ
S5	2008 - 2012	All	PR-1LJ
S5	2013	000001 - 038944	PR-1LJ
S5 Cabriolet	2010 - 2012	All	PR-1LJ
S5 Cabriolet	2013	000001 - 006403	PR-1LJ

Condition

REVISION HISTORY		
Revision	Date	Purpose
10	-	Revised header data (Corrected Elsa display issue)
9	6/29/2015	Revised header data (Updated VIN range) Revised <i>Required Parts and Tools</i> (Updated part numbers) Revised <i>Service</i> (Procedure updates)
8	7/21/2014	Revised <i>Condition</i> (Added Note) Revised <i>Service</i> (Clarified information) Revised <i>Warranty</i> (Updated labor operations)

Customer may complain about brake squeak or squeal with light to moderate pedal pressure.

Technical Background

If any of the following conditions exist, this TSB does not apply.

- Front brake discs or brake pads are close to their wear limit (disc wear limit: 28 mm and pads wear limit with backing plate and dampening plate: 10 mm).
- Foreign objects between brake disc and brake pad, such as small stones, grit, rust build-up, or sand.
- Un-ground or corroded friction materials.
- Metallic deposits from disc material in brake pad (Figure 1).



Figure 1. Metallic deposits.

Production Solution

Three unique improvements were released in three different model years.

Service

1. Use ETKA to verify the vehicle build date and the front brake PR code.
2. Use this data to determine which scenario applies to the vehicle to perform the correct repair. Only one scenario can be applied to the vehicle.

Scenario A:

Cars built *before* June 20, 2011 with PR-1LJ

Scenario B:

- Cars built *before* June 20, 2011 with PR-1ZT
- Cars built *on or after* June 20, 2011 but before December 6, 2013 with PR-1LJ

Scenario A

1. Install the parts listed in the *Required Parts and Tools* table according to Elsa.
2. Apply a thin coat of anti-seize (G 052560A2) lubricant to the guide pins of the front caliper carriers prior to installing the brake pads (Figure 2).

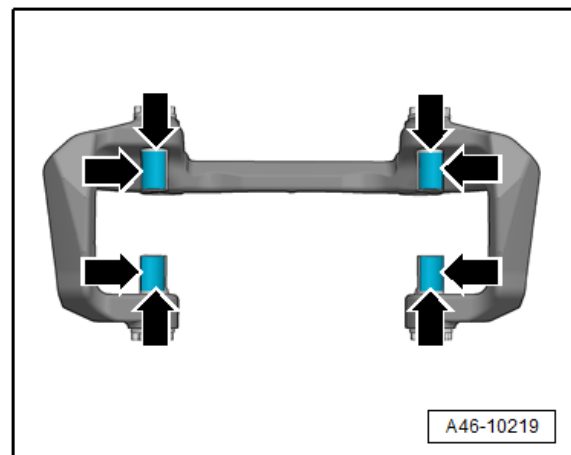

Figure 2. Caliper carrier guide pins with anti-seize (G 052560A2) lubricant applied where the pads make contact.

3. Follow all instructions in TSB 2011732: *00 Software Management (SVM), operating instructions*, to update the vehicles front brake PR code data using the SVM action code listed in the table below. Use Audi Flashing >> *Software Version Management (SVM) >> SVM – Direct input: SVM code for vehicle conversion.*

Models	Old front brake PR code	New front brake PR code	SVM Action Code
S4 / S5 / S5 Cabriolet	PR-1LJ (345x29.5MM front discs)	PR-1ZT (345x30MM front discs)	03A004



Tip: The change is necessary to ensure correct parts are installed during future brake service. This SVM code should only be performed for repairs listed in **Scenario A**. PR-1ZT indicates that **Scenario A** repairs were previously performed

Scenario B:

1. Check the part number on the front discs. If part number is *not* 4G0615301G, install 4G0615301G front discs (Figure 3).

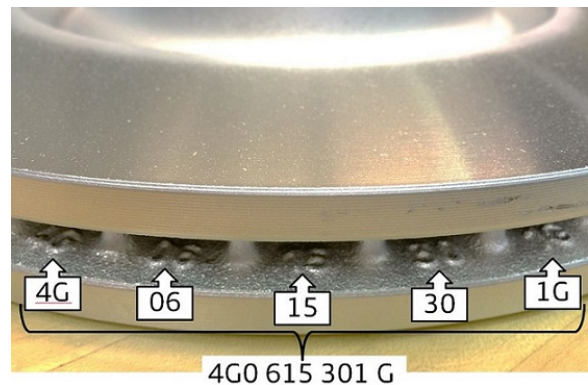

Figure 3. Front brake disc part number location.

2. Apply a thin coat of anti-seize (**G 052560A2**) lubricant to the guide pins of the caliper carrier (Figure 4).

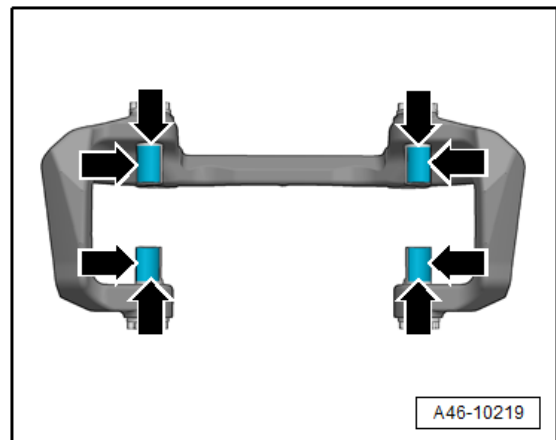

Figure 4. Caliper carrier guide pins with anti-seize (**G 052560A2**) lubricant applied where the pads make contact.

Brake embedding – follow this procedure if front pads and/or discs are replaced.

1. Perform 10 stops from approximately 35 mph to 10 mph with medium pedal pressure.
2. Drive for approximately 5 minutes without braking to allow the brakes to cool down.
3. Perform 10 stops from approximately 35 mph to 10 mph with medium pedal pressure.
4. Drive for approximately 5 minutes without braking to allow the brakes to cool down.
5. Repeat steps 1 and 2 if necessary.
6. Do not perform ABS stops as a way of embedding the brakes. Brake pads and discs may be permanently damaged.



Tip: If the vehicle still exhibits brake noise after all the repairs stated above have been accurately performed:

- Obtain a sound recording, create a TAC ticket, and attach the sound recording.
- Do not open a TAC ticket without a sound recording.

Technical Service Bulletin



Warranty

There must be an original customer complaint of the specified symptom on the repair order for this Technical Service Bulletin to apply. Adding this procedure on is not permitted.

Claim Type:	110		
Service Number:	4617		
Damage Code:	0020		
Labor Operations:	Scenario A		
	2 Wheels remove and reinstall	4405 2000	20 TU
	2 Brake pads, front remove and reinstall Includes replacing 2 caliper carriers, cleaning guide pins and applying G 052560A2	4636 2050	50 TU
	2 Front brake disc remove and reinstall Includes front brake caliper loosened and fastened	4650 2050	40 TU
	SVM update	0150 0000	Time stated on diagnostic protocol (Max 30 TU)
	Scenario B: without discs		
	2 Wheels remove and reinstall	4405 2000	20 TU
	Front brake calipers separated from caliper carriers to clean guide pins and apply G 052560A2	4739 2099	40 TU
	Scenario B: with discs		
	2 Wheels remove and reinstall	4405 2000	20 TU
	2 Front brake disc remove and reinstall Includes front brake caliper loosened and fastened	4650 2050	40 TU
	Front brake calipers separated from caliper carriers to clean guide pins and apply G 052560A2	4739 2099	40 TU
	Diagnostic Time:	Road test prior to service procedure	0121 0002
Road test after service procedure		0121 0004	10 TU
Technical diagnosis at dealer's discretion			

Technical Service Bulletin



	(Refer to Section 2.2.1.2 and Audi Warranty Online for DADP allowance details)
Claim Comment:	As per TSB #2027636/10

All warranty claims submitted for payment must be in accordance with the *Audi Warranty Policies and Procedures Manual*. Claims are subject to review or audit by Audi Warranty.

Required Parts and Tools

Part Number	Part Description	Quantity
G 052560A2	Anti-seize lubricant	0.10
4G0615301G	Front brake discs	2
8R0698151	Set of brake pads with wear indicator (1 set)	1
8T0615125A	Caliper carrier	2
N 91147601	Bolt, hex.hd. with shoul. (combi) M14X1,5X48	4
N 10648301	Hex socket countersunk bolt M6X16	2

Additional Information

The following Technical Service Bulletin(s) will be necessary to complete this procedure:

- TSB 2011732: *00 Software Management (SVM), operating instructions*

All parts and service references provided in this TSB (2027636) are subject to change and/or removal. Always check with your Parts Department and service manuals for the latest information.