

Turbocharger Outlet Pipe VN

FSB 252-031, Turbocharger Outlet Pipe

(September 2015)

Some Volvo vehicles equipped with Cummins ISL engine may have a cracked turbocharger outlet pipe. The crack develops at the flange to pipe weld area. There is a new support bracket to take load and vibration out of the joint area and eliminate future failures.

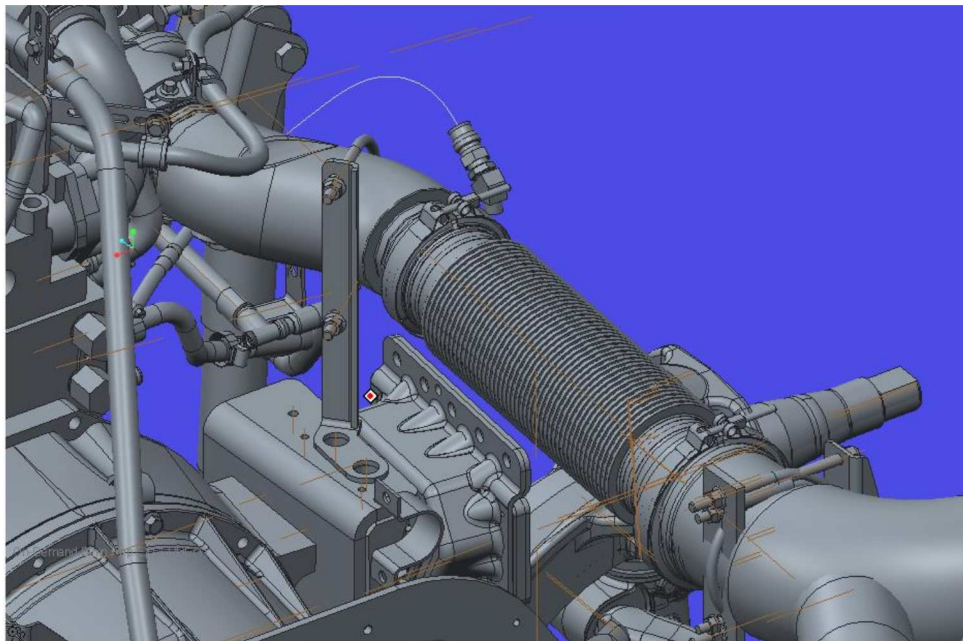

W2106127

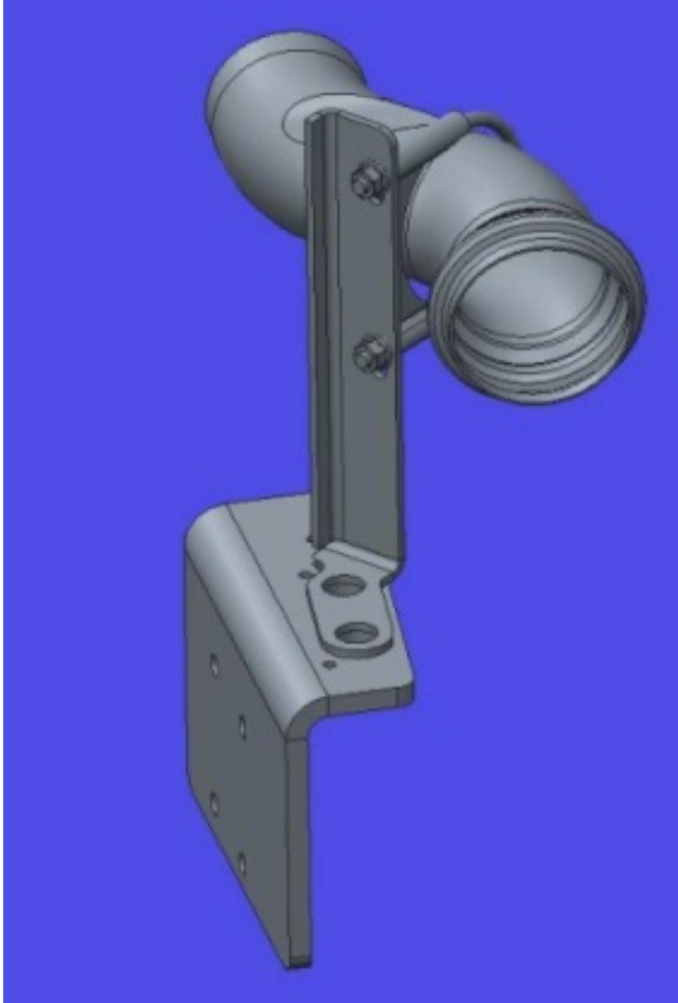

W2106128

Required Parts

Description	Part Number	Quantity
Support Bracket	22742843	1
Clamp	22758203	1