

**Engine Harness Changes**  
**D11J, D13J**  
**VAH, VHD, VN**

**FSB 284-056, Engine Harness Changes**

(April 2015)

VOLVO Trucks has released a new engine harness for D11J and D13J US2014 emission engines in 2015 model year vehicles. The new harness is backwards compatible to all 2014 production vehicles. The retaining clamps have changed from metal to plastic with metal inserts and are integrated into the harness. Should an engine harness need to be replaced for any reason, the replacement harness will be this new style.

**Serial Number Start**

D11J Engines	570997
D13J Engines	1103115

Changes include:

- D13 Engine Only: Yellow marking tape added to crankcase pressure sensor wire. Blue marking tape removed from oil pressure sensor wire.

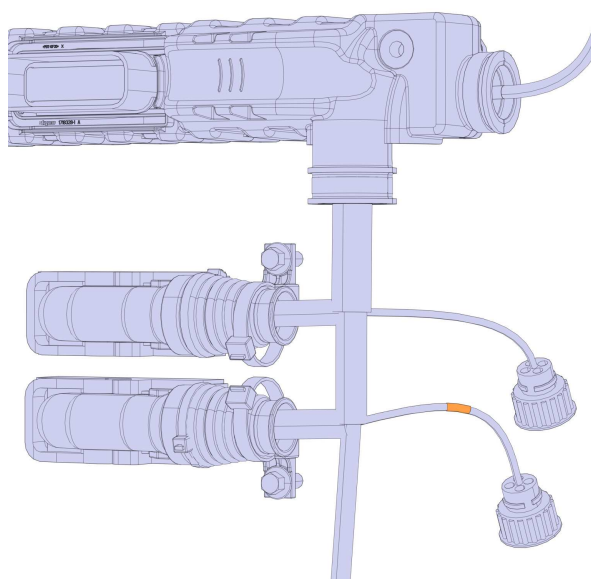

W2100467

Service personnel: Please circulate, read and initial

Service Manager	Warranty Administrator	Workshop Foreman	Service Technicians					

- The starter solenoid wires now come from the front. Previous starter wire routed around the cold side of engine around the rear.

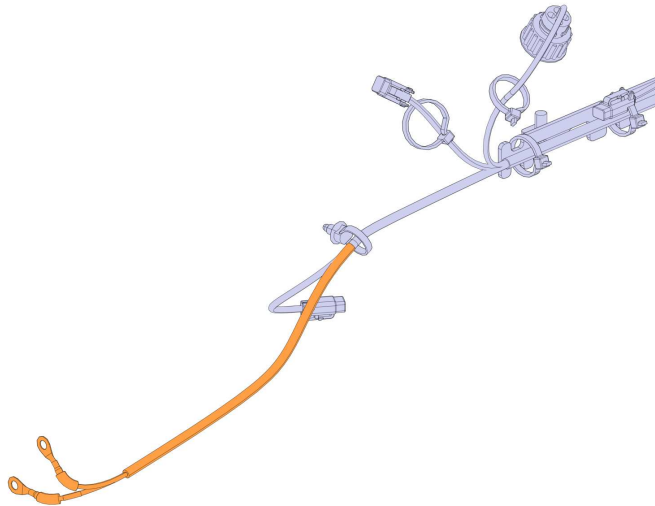

W2100052

- D13 Engine Only: Crankshaft speed sensor has yellow marking tape on it so it is not confused with EGR valve sensor. Stud-mounted cable tie added.

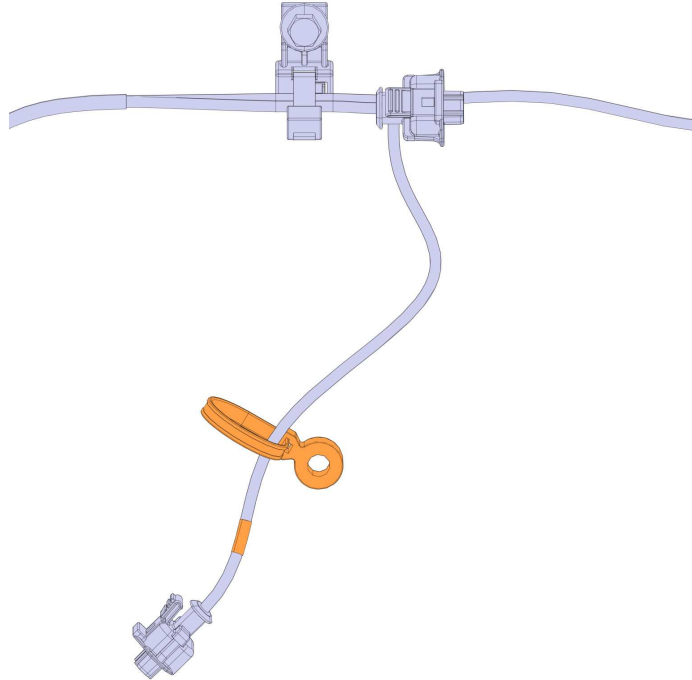

W2100055