

# PREVOST

## WARRANTY BULLETIN

**WB15-06C**

DATE :	FEBRUARY 2015	SECTION :	06 - Electrical
EXPIRATION:	FEBRUARY 2017		
SUBJECT :	067954 CURRENT SENSOR INSPECTION AND REPLACEMENT		

REVISION C This bulletin supersedes previous versions  
 March 16, 2015 : Added Vehicles. Added Step 13: check S/N of new part.

### APPLICATION

<b>NOTICE TO SERVICE CENTERS</b>	
<i>Verify vehicle eligibility by checking warranty bulletin status with <b>SAP</b> or via <b>ONLINE WARRANTY SYSTEM</b> available on Service / Warranty tab of Prevost website.</i>	
Model	VIN
H3-45 coaches Model Year : 2015	 Single vehicles 2PCH33493FC71 <b>2878</b> 2PCH33490FC71 <b>2918</b> , 2PCH33499FC71 <b>2920</b> , 2PCH33490FC71 <b>2921</b>
H3-45 VIP motorhomes Model Year : 2015	Single vehicles : 2PCVS3493FC71 <b>2885</b> , 2PCVS3499FC71 <b>2888</b> 2PCV33499FC71 <b>2919</b>
X3-45 coaches Model Year : 2015	Single vehicles : 2PCG33499FC73 <b>5819</b> , 2PCG33497FC73 <b>5821</b> 2PCG33490FC73 <b>5823</b> , 2PCG33492FC73 <b>5824</b> , 2PCG33494FC73 <b>5825</b> 2PCG33498FC73 <b>5830</b> , 2PCG33498FC73 <b>5861</b> , 2PCG3349XFC73 <b>5862</b> 2PCG33493FC73 <b>5864</b> , 2PCG33497FC73 <b>5866</b> , 2PCG33499FC73 <b>5867</b> 2PCG33490FC73 <b>5868</b> , 2PCG33492FC73 <b>5869</b> , 2PCG33499FC73 <b>5870</b>
X3-45 VIP commercial use Model Year : 2015	Single vehicle 2PCCS3494FC73 <b>5812</b> 2PCCS3499FC73 <b>5871</b> , 2PCCS349XFC73 <b>5877</b>
X3-45 VIP motorhomes Model Year : 2015	Single vehicles : 2PCBS3497FC73 <b>5816</b> , 2PCBS3490FC73 <b>5818</b> 2PCBS3499FC73 <b>5865</b>

### DESCRIPTION

On the vehicles affected by this bulletin, inspect the serial number of the current sensors in the battery compartment and follow instructions to perform replacement if applicable. A number of sensors have been identified by the manufacturer as having a calibration outside specifications.

## MATERIAL

Order the following parts:

Part No.	Description	Qty
067954	Current sensor 80/600 amp	2

Other parts that may be required:

Part No.	Description	Qty
5001694	MACHINE SCREW, PAN PH M4-0.7x40 SS BLACK	2

### *NOTE*

*Material can be obtained through regular channels.*

## SPECIAL TOOLS



Figure 1 : Mini ratchet, female 1/4 hex drive or equivalent



Figure 2 : Flex ratchet extension



Figure 3 : 1/4 Hex to 1/4 Square adapter

## PROCEDURE

DANGER

Park vehicle safely, apply parking brake, stop engine and set battery master switch(es) to the OFF position prior to working on the vehicle.

1. Open rear electrical compartment.(Fig.1 & 2)

*We recommend disconnecting the battery ground prior to inspection to prevent accidental reconnection. (Fig. 9 & 10)*

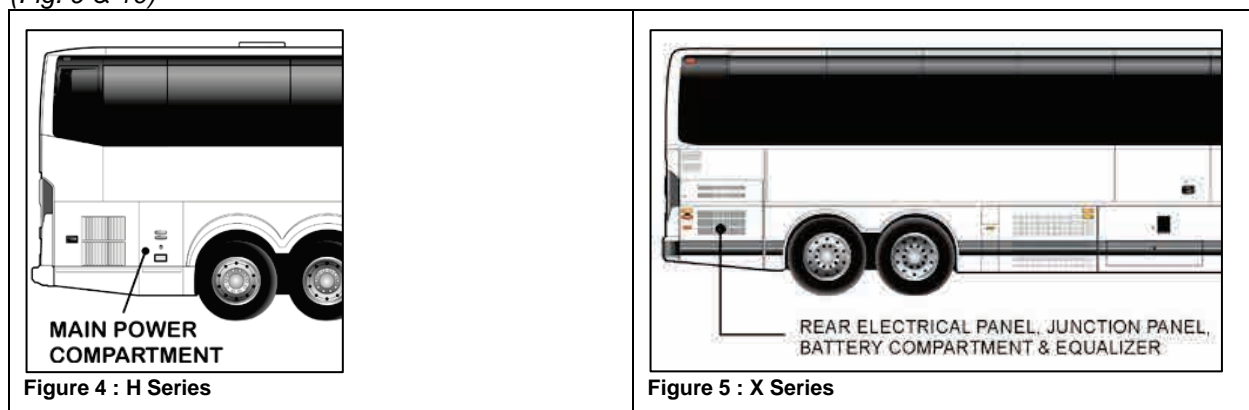

2. Locate sensors next to batteries (Fig 7 & 8). Defective Sensors have a serial number starting with **14300, 14307 or 14314** (Fig 6). If found, consult **Table 2** below to confirm serial number is part of list.

**H series vehicles:** *we recommend using an inspection mirror.*

Also, note that green dot labels (Fig. 16) have been applied to the sensor to attest calibration by the supplier. Refer to **Table 1** below to know if part should be replaced.

# of green dots	Serial # found In Table 2?	Good part?	Do I perform replacement?
1	Yes →	No→	<b>YES</b>
1	No→	Yes→	NO
2	Yes→	Yes→	NO
2	No→	Yes→	NO

Table 1



Figure 6: Typical Current Sensor.

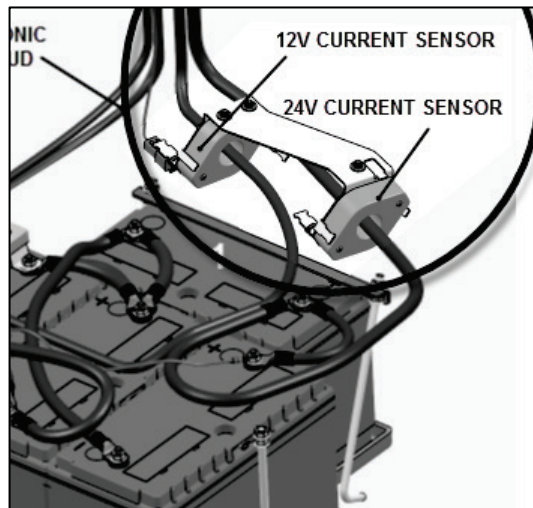

Figure 7 : H series

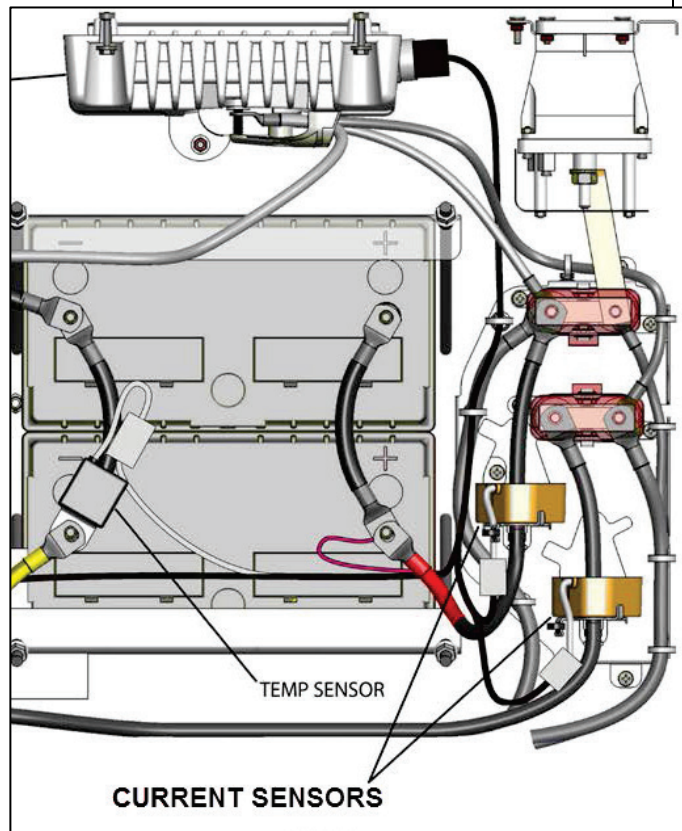

Figure 8 : X series

3. Replace faulty sensor following instructions below. Reserve hardware for re-assembly.
4. Reserve removed sensor for warranty return process.
5. **Make sure battery ground on left side of battery bank is removed before performing any work.**



Figure 9 : H Series Ground



Figure 10 : X Series Ground

6. Remove 12V and / or 24 V power cables to allow sensor removal. (Fig. 11 & 12)

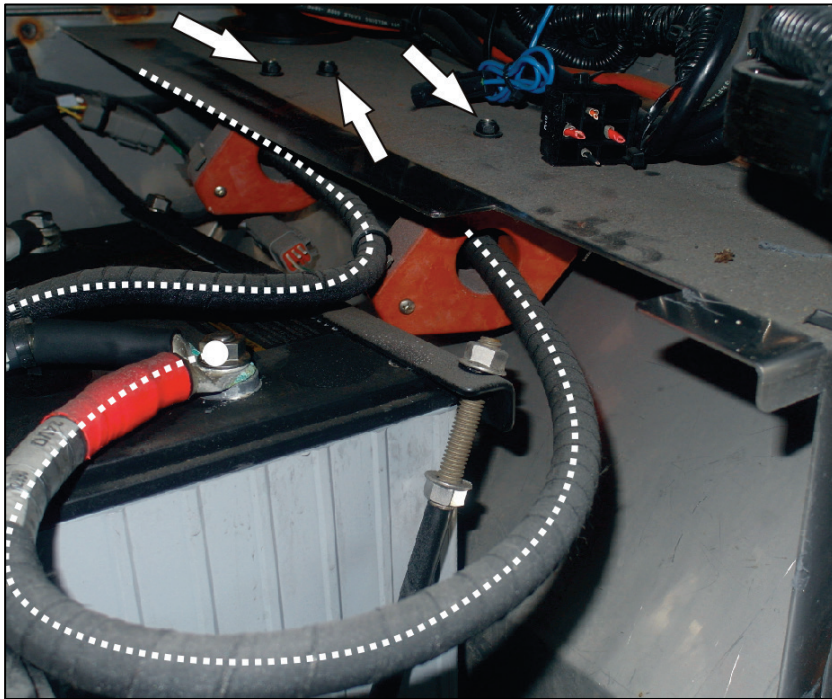

Figure 11 : H Series Power Cables

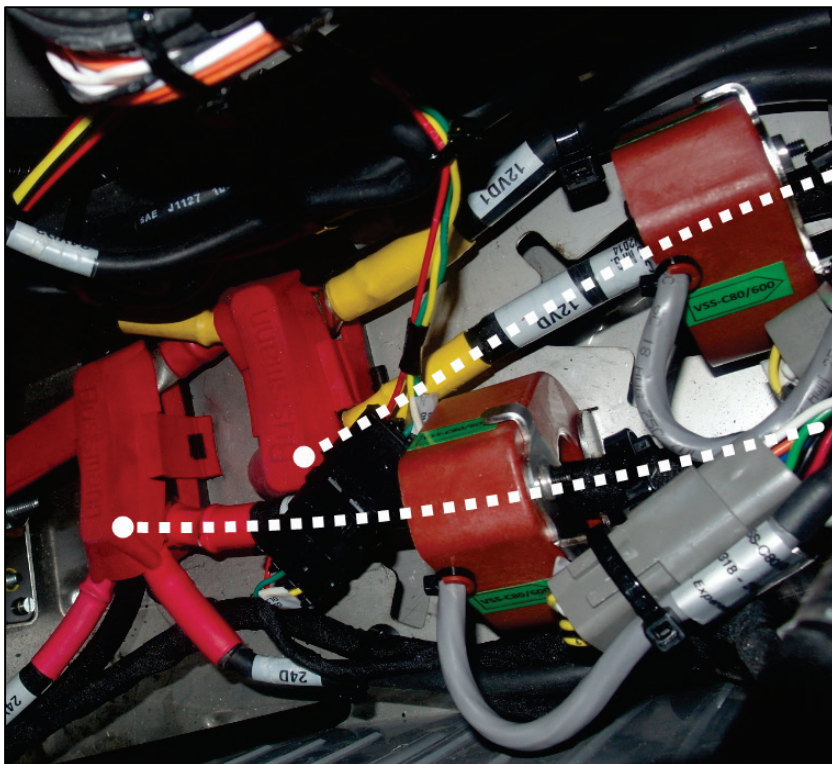

Figure 12 : X Series Power Cables

7. Remove sensors (Fig. 13 & 15)
8. H Series: remove mounting plate nuts. Reserve for re-assembly.
9. Remove Sensor mounting screws on a workbench.  
(Mounting Screw #5001694 Pan Head, Philips M4 x 40mm)

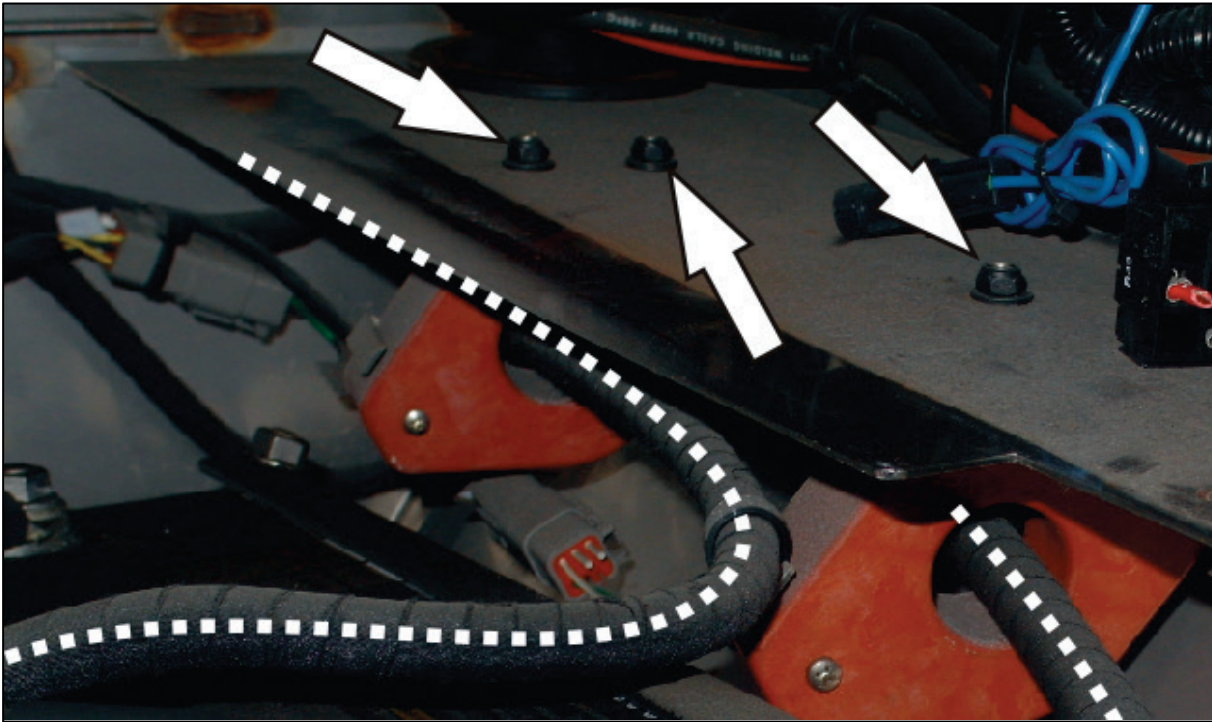

Figure 13 : H series sensor mounting screws

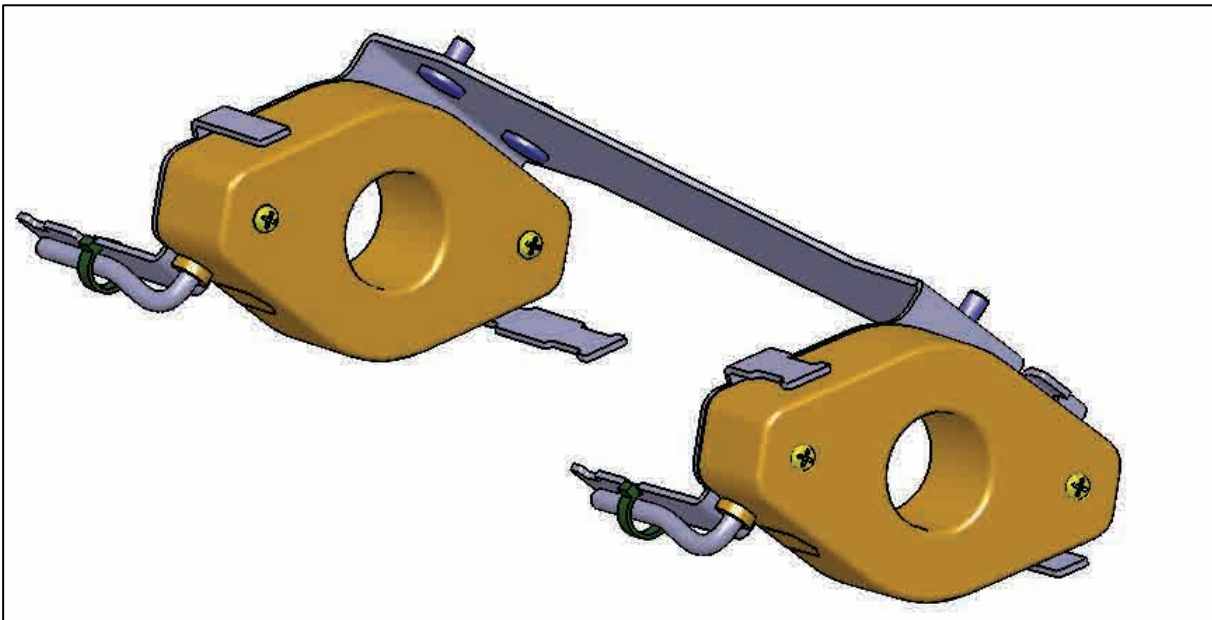

Figure 14 H Series Sensor Mounting Plate

11. X Series: To remove the lower screws, use the smallest ratchet possible and a flex ratchet extension (Fig. 1, 2). (Mounting Screw #5001694 Pan Head, Philips M4 x 40mm)

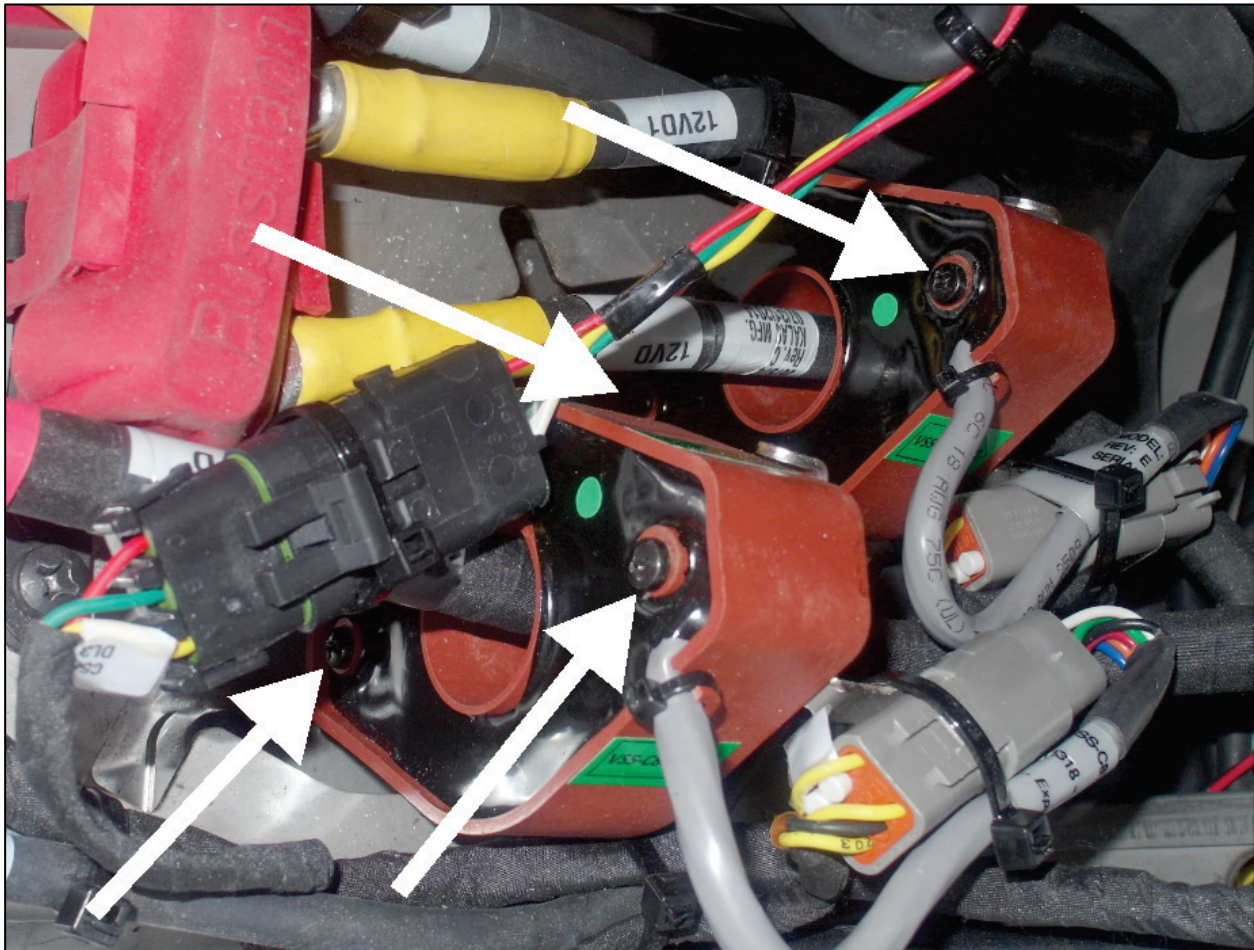

Figure 15 : X series sensor mounting screws

12. Replace sensor by a new #067954.
13. Make sure new part's serial number is not part of defective list in table 2.
14. Reconnect 12V and / or 24 V cables. Tighten to 170 lbf-in (14 lbf-ft)
15. Reconnect ground cable last. Tighten to 170 lbf-in (14 lbf-ft)

**Table 2: Defective 067954 Current Sensor Serial Number List.**

*IF SERIAL NUMBER IS FOUND BELOW, REPLACE PART ONLY IF IT BEARS ONE GREEN DOT ;*

*IF PART BEARS TWO GREEN DOTS, PART IS CONSIDERED GOOD (NO REPLACEMENT) (FIG. 16)*



14300-274146	14307-274645	14311-275500
14300-274147	14307-274647	14311-275502
14300-274148	14307-274648	14311-275503
14300-274149	14307-274649	14311-275505
14300-274150	14307-274650	14311-275507
14300-274151	14307-274651	14311-275511
14300-274161	14307-274652	14311-275514
14300-274163	14307-274653	14311-275515
14300-274164	14307-274654	14311-275516
14300-274165	14307-274655	14311-275517
14300-274166	14307-274656	14311-275518
14300-274167	14307-274657	14311-275519
14300-274168	14307-274658	14311-275520
14300-274172	14307-274659	14311-275521
14300-274174	14307-274662	14311-275522
14300-274175	14307-274663	14311-275524
14300-274176	14307-274664	14311-275525
14300-274177	14307-274665	14311-275527
14300-274178	14307-274666	14311-275528
14300-274179	14307-274668	14314-275742
14300-274181	14307-274670	14314-275743
14300-274183	14307-274671	14314-275745
14300-274184	14307-274672	14314-275747
14300-274185	14307-274673	14314-275748
14300-274186	14307-274678	14314-275749
14300-274187	14307-274680	14314-275750
14300-274188	14307-274681	14314-275751
14300-274189	14307-274682	14314-275752
14300-274190	14307-274683	14314-275753
14300-274193	14307-274685	14314-275754
	14307-274686	14314-275755
	14307-274687	
	14307-274688	
	14307-274689	
	14307-274690	
	14307-274691	
	14307-274692	
	14307-274693	

Table 2

**TWO GREEN DOTS: PART IS OK!  
(PART HAS BEEN RECALIBRATED BY SUPPLIER)**



Figure 16 : Recalibrated “good” sensor

## PARTS / WASTE DISPOSAL

All replaced parts must be returned to Prevest according to the Return Shipping Instructions available on <https://www.prevestcar.com/content/warranty-documents> for full reimbursement. A copy of the warranty claim form must be enclosed with the shipment.

Discard waste according to applicable environmental regulations (Municipal/State[Prov.]/ Federal)

## WARRANTY

This modification is covered by Prevest's normal warranty. We will reimburse you the parts and one hour (1.0h) of labor upon receipt of a warranty claim. Please submit claim via our Online Warranty System, available at [www.prevestcar.com](http://www.prevestcar.com) (under Service \ Warranty section). Use Claim Type: "Bulletin/Recall" and select "Warranty Bulletin WB15-06".

## OTHER

VBC Bulletin	N/A
Fail Code	06.10
Defect Code	09
Syst.Cond.	B
Causal Part	067954

Access all our Service Bulletins on <https://secureus5.volvo.com/technicalpublications/en/pub.asp> or scan the QR-Code with your smart phone.

E-mail us at [technicalpublications\\_prev@volvo.com](mailto:technicalpublications_prev@volvo.com) and type "ADD" in the subject to receive our warranty bulletins by e-mail.

