



Service Bulletin

PRELIMINARY INFORMATION

Subject: Change Power Steering Fluid to DEXRON®-VI When Replacing Steering Gear Assembly

Models: 2008-2012 Buick Enclave
2009-2012 Chevrolet Traverse
2007-2012 GMC Acadia
2007-2010 Saturn OUTLOOK
Built Prior to July 01, 2011

Attention: This bulletin also applies to any of the above models that may be Export vehicles.

This PI has been revised to remove the WPC information and update the Warranty Information. Please discard PI0620.

To prevent future repairs for a steering gear squeak noise (as outlined in PI0029F), GM is recommending that the fluid be changed to DEXRON®-VI automatic transmission fluid when a steering gear assembly is replaced for any reason.

Technicians should make every attempt to confirm whether the power steering system has already been converted to DEXRON®-VI as a result of PI0029F being performed by checking the vehicles transaction history Global Warranty Management (GWM). If the power steering system has original fluid, the system should be flushed and refilled with DEXRON®-VI using the procedure listed below.

The recommendation to convert power steering fluid to DEXRON®-VI automatic transmission fluid is for gear replacements only and not for repairs to other system components, such as pump, cooler or hoses. The service gear shipping box will contain a tag that will identify the vehicle has been converted to DEXRON®-VI. The tag should be installed on the power steering reservoir filler neck and secured with the cap.

Power Steering System Flush Procedure

Important: Due to the interface between the pinion shaft seal and the fluid, it is critical to ensure that no old fluid comes in contact with the new seal. Be sure to thoroughly flush all old fluid from the system prior to installing the new steering gear assembly.

1. Raise and support the vehicle until the wheels are approximately 61 cm (24 in) off the ground.
2. Place a large container under the vehicle in order to collect the draining fluid.

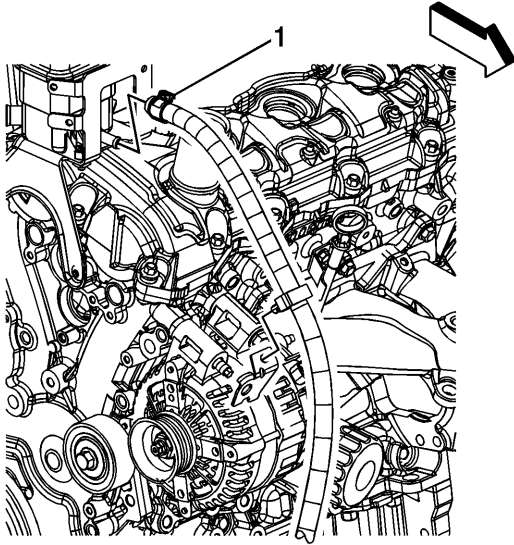

3. Loosen the hose clamp (1) and disconnect the power steering fluid reservoir inlet hose from the power steering fluid reservoir.
4. Plug the power steering fluid reservoir inlet port.

Note: This step may require 3 L (3 qt) of DEXRON®-VI fluid until the draining fluid appears red.

5. With the key ON and the engine OFF, turn the steering wheel fully to the left and to the right while an assistant maintains the minimum fluid level in the reservoir using DEXRON®-VI Automatic Transmission Fluid. Continue until the fluid from the power steering fluid reservoir inlet hose runs red.
6. Remove the plug from the power steering fluid reservoir inlet port.
7. Connect the power steering fluid reservoir inlet hose to the reservoir and secure the hose with the clamp.

Parts Information

Part Number	Description	Qty
88861003 (In Canada, use 19264717)	DEXRON®-VI Automatic Transmission Fluid	5

Warranty Information

For vehicles repaired under warranty, use:

Labor Operation	Description	Labor Time
7421740	Steering Gear Replacement	Use Published Labor Operation Time

GM bulletins are intended for use by professional technicians, NOT a "do-it-yourselfer". They are written to inform these technicians of conditions that may occur on some vehicles, or to provide information that could assist in the proper service of a vehicle. Properly trained technicians have the equipment, tools, safety instructions, and know-how to do a job properly and safely. If a condition is described, DO NOT assume that the bulletin applies to your vehicle, or that your vehicle will have that condition. See your GM dealer for information on whether your vehicle may benefit from the information.



WE SUPPORT VOLUNTARY TECHNICIAN CERTIFICATION