

SERVICE PROCEDURE

15506
JUNE, 2015

SUBJECT: SAFETY RECALL
Front Driveshaft on certain 4800 models built 30 June 1999 thru 28 May 2002 with certain Fabco TC-200 transfer case (feature code 013TJZ only).

NOTE: This Recall is the final remedy and supersedes Safety Recall 14514.

DEFECT DESCRIPTION

A seized double Cardan joint can cause either the driveline joint to fail, or a non-axial rotation could result in the shaft breaking in the tube section of the shaft. This could result in eventual front driveshaft separation, or if the shaft breaks midway, the front portion of the shaft could hit a part of the vehicle, which could cause front axle lock up.

MODELS INVOLVED

This Safety Recall involves certain 4800 models built 30 June 1999 thru 28 May 2002 with certain Fabco TC-200 transfer cases (feature code 013TJZ only).

NOTE: When necessary, if the front driveshaft was not previously removed, and the customer is a considerable distance from your location and does not want to drive the vehicle on the highway with the shaft installed, the service technician is authorized to travel to the customer location to perform ONLY the installation of lockout hubs to allow the vehicle to be driven to the service location for the remainder of the repair.

PARTS INFORMATION

Part Number	Part Description	Quantity
8900252R91	Kit, 4800 Retrofit	1
8900251R91	Kit, Fabco Hub	1

8900252R91 contains the following parts:

Part Description	Quantity
Forward Bracket	1
Forward U-bolt	1
Rear Bracket	1
Rear U-bolt	1
Nut, Hex Jam, 3/4 inch -16 GR 5, PHC	8
Washers, 3/4 inch	8

8900251R91 contains the following parts:

Part Description	Quantity
Hub Lock, Manual, Heavy Duty	2
Washer – 1/2 inch Type A Narrow-STD-Hardened	16
1/2 inch Lock Nut	16

SERVICE PROCEDURE

NOTE: This procedure includes certain steps specific to vehicles equipped with double C-channel frame rails. It is recommended that the technician performing this service procedure familiarizes themselves with this document prior to performing service.

WARNING! TO PREVENT PROPERTY DAMAGE, PERSONAL INJURY, AND / OR DEATH, PARK VEHICLE ON HARD FLAT SURFACE, TURN THE ENGINE OFF, SET THE PARKING BRAKE AND INSTALL WHEEL CHOCKS TO PREVENT THE VEHICLE FROM MOVING IN BOTH DIRECTIONS.

WARNING! TO PREVENT PROPERTY DAMAGE, PERSONAL INJURY, AND / OR DEATH, IF THE VEHICLE MUST BE RAISED, DO NOT WORK UNDER THE VEHICLE SUPPORTED ONLY BY JACKS. JACKS CAN SLIP OR FALL OVER.

WARNING! TO PREVENT PERSONAL INJURY AND / OR DEATH, ALWAYS WEAR SAFE EYE PROTECTION WHEN PERFORMING VEHICLE MAINTENANCE.

WARNING! TO PREVENT PROPERTY DAMAGE, PERSONAL INJURY, AND / OR DEATH, ALLOW COMPONENTS IN ENGINE COMPARTMENT TO COOL BEFORE SERVICING ENGINE OR VEHICLE.

WARNING! TO PREVENT PROPERTY DAMAGE, PERSONAL INJURY, AND / OR DEATH, KEEP FLAMES OR SPARKS AWAY FROM VEHICLE AND DO NOT SMOKE WHILE SERVICING THE VEHICLE'S BATTERIES. BATTERIES EXPEL EXPLOSIVE GASES.

DRIVESHAFT INSPECTION

1. Park vehicle on a flat surface with wheels straight ahead.
2. Shift transmission to Park or Neutral and set parking brakes.
3. Install wheel chocks.

NOTE: DO NOT perform front wheel hub modification if a vehicle front drive assembly was modified as listed in Step 4 below.

4. Inspect front driveshaft for the following:
 - a. Transfer case was repositioned by Truck Equipment Manufacturer (TEM) due to specialized truck body installation.
 - b. Center bearing was installed.
 - c. The suspect vehicles were originally built with one driveshaft and the vehicle you are working on has two driveshafts.
5. If any of the conditions exist in Step 4, **DO NOT** remove the front driveshaft and proceed to Step 50; otherwise, proceed to Step 6.

NOTE: If the vehicle you are working on is marked for Safety Recall 05501 and it has not been performed, please perform Recall 05501 and then proceed to Step 26 in this recall.

NOTE: If the vehicle you are working on is equipped with a double C-channel frame rail, the front double Cardan driveshaft must be removed to install the front drive shaft loop bracket. Once drive shaft is removed for Cardan joint inspections, perform Steps 26 through 33 before reinstallation of driveshaft.

6. If front driveshaft was previously removed from the vehicle you are working on, perform Steps 16 - 25; otherwise, perform Steps 7 - 15.

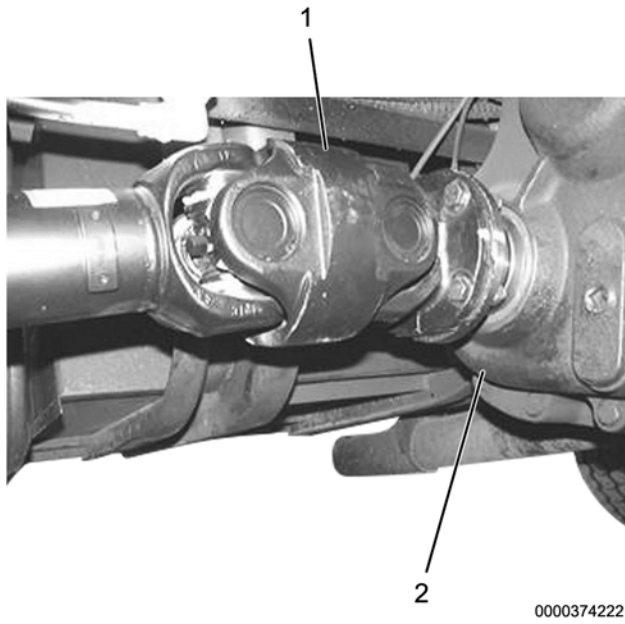
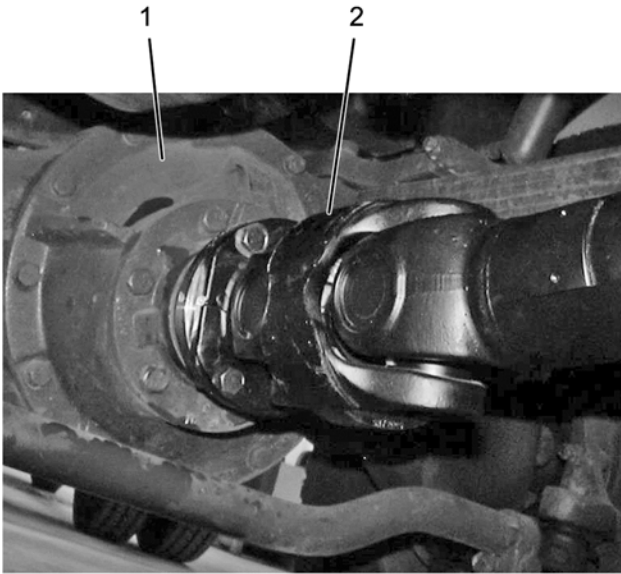

Figure 1. Transfer Case.

1. Cardan joint
2. Transfer case

NOTE: When disconnecting the driveshaft, it is important the shaft is supported at roughly the installed angle. DO NOT allow the weight of the shaft to rotate either Cardan joint to its maximum angle. Allowing the Cardan joint to rotate to its maximum angle can cause damage to the joint.

7. Remove four bolts, nuts, and washers, and disconnect driveshaft from front yoke of transfer case (Figure 1, Item 2). Place shaft on a jack stand at roughly the installed angle to support the joint. **DO NOT** allow the weight of driveshaft to rotate Cardan joint (Figure 1, Item 1) to its maximum angle.
8. Inspect Cardan joint by rotating U-joints by hand to feel for any looseness or binding. If any issue is found, open a technical service case file for approval to order and replace driveshaft. Once approved, you will receive the part number and SRT time to replace driveshaft.
9. If the vehicle you are working on is equipped with a double C-channel frame rail, perform Steps 26 through 33 before connecting driveshaft to front yoke of transfer case in Step 10.
10. Connect driveshaft to front yoke of transfer case, and install four bolts, nuts, and washers.
11. Using torque wrench, tighten bolts to 88 - 92 lb-ft (120 - 124 N·m).



0000374223

Figure 2. Front Axle Differential.

1. Front axle differential
2. Cardan joint

12. Remove four bolts and disconnect front driveshaft from front axle differential (Figure 2, Item 1). Place the front Cardan joint (Figure 2, Item 2) on a jack stand at roughly the installed angle to support the joint. **DO NOT** allow the weight of shaft to rotate Cardan joint to its maximum angle.
13. Inspect Cardan joint by rotating U-joints by hand to feel for any looseness or binding. If any issue is found, open a technical service case file for approval to order and replace driveshaft. Once approved, you will receive the part number and SRT time to replace driveshaft.
14. Connect front driveshaft to front axle and install four bolts.
15. Using torque wrench, tighten bolts to 88 - 92 lb-ft (120 - 124 N·m).
16. If driveshaft of the vehicle you are working on was previously removed, verify the VIN number on the driveshaft assembly matches the VIN number of the unit you are working on and remove protective banding.
17. Inspect the driveshaft. Rotate U-joints at both ends of shaft by hand to feel for any looseness or binding. If any issue is found, open a technical service case file for approval to order and replace driveshaft. Once approved, you will receive the part number for replacement driveshaft.

NOTE: When installing the driveshaft, it is important the shaft is supported at roughly the installed angle. DO NOT allow the weight of the shaft to rotate the Cardan joint to its maximum angle. Allowing the Cardan joint to rotate to its maximum angle can cause damage to the joint.

NOTE: If the orientation markings are missing from the ends of the driveshaft, install driveshaft with slip joint towards the rear of the vehicle.

18. If the vehicle you are working on is equipped with a double C-channel frame rail, perform Steps 26 through 33 before orienting driveshaft in Step 19.
19. Using the markings on each end of driveshaft, orient driveshaft so each end will connect to their original mating component.
20. Place each Cardan joint on a jack to support the joint. DO NOT allow the weight of the shaft to rotate the Cardan joint to its maximum angle. Allowing the Cardan joint to rotate to its maximum angle can cause damage to the joint.
21. Position driveshaft under vehicle and raise both ends into position to reconnect driveshaft.

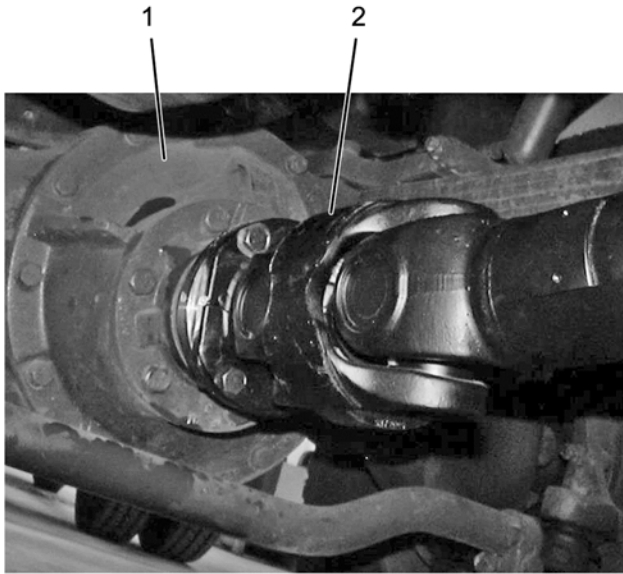

0000374223

Figure 3. Front Axle Differential – Cardan Joint.

1. Front axle differential
2. Cardan joint

NOTE: It is very important that you install the drive axle yoke first.

22. Connect front driveshaft Cardan joint (Figure 3, Item 2) to front axle differential (Figure 3, Item 1) and install four bolts.

23. Using torque wrench, tighten bolts to 88 - 92 lb-ft (120 - 124 N·m).

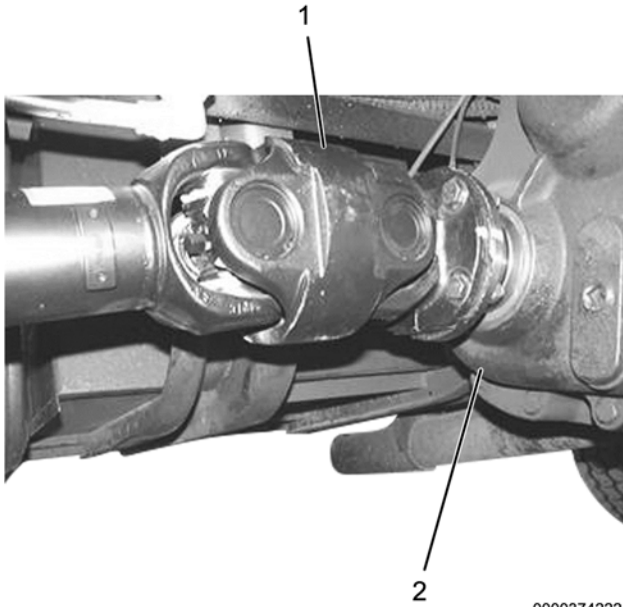

Figure 4. Transfer Case.

1. Front driveshaft
2. Transfer case

24. Connect front driveshaft (Figure 4, Item 1) to front yoke of transfer case (Figure 4, Item 2), and install four bolts, nuts and washers.

25. Using torque wrench, tighten bolts to 88 - 92 lb-ft (120 - 124 N·m).

DRIVESHAFT GUARD INSTALLATION

NOTE: The following steps MUST be performed with the front of the vehicle raised, supported by the frame with the front tires off the ground.

26. Raise front of vehicle with suitable lifting device and support frame with suitable jack stands so front tires are off the ground.

27. Raise front axle enough to lift weight off of suspension components.

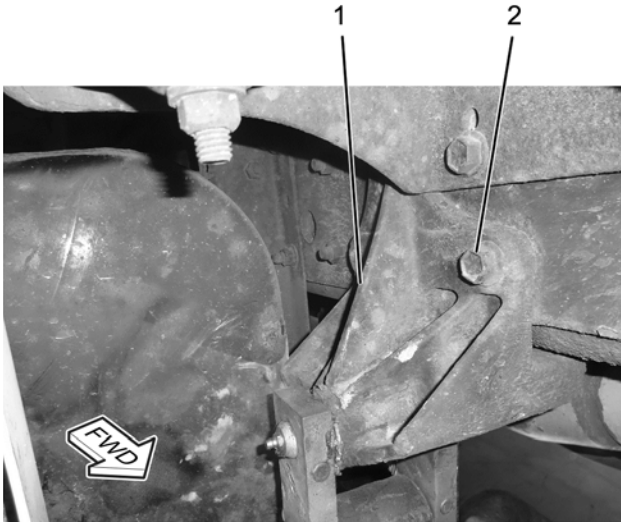

0000374224

Figure 5. Front Axle Rear Spring Hanger – Passenger Side.

1. Rear spring hanger
2. Bolt (2) (One not shown)

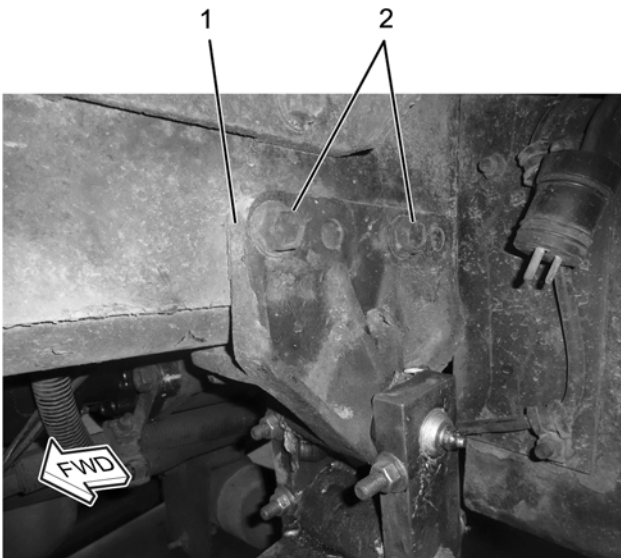

0000374225

Figure 6. Front Axle Rear Spring Hanger – Driver Side.

1. Rear spring hanger
2. Bolt (2)

28. Double C-channel equipped vehicles perform step 28a, all other vehicles perform Step 28b:

- a) Remove only bottom bolts securing both driver and passenger front spring hangers and frame.

- b) Remove all bolts (Figure 5, Item 2, Figure 6, Item 2) that secure both passenger and driver front axle rear spring hangers (Figure 5, Item 1, Figure 6, Item 1) to frame rails. Save fasteners for reuse.

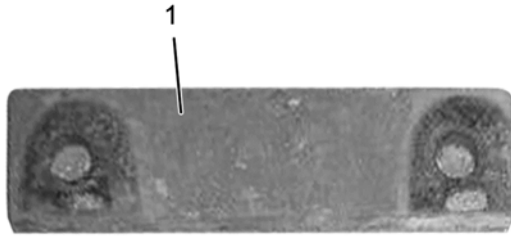

0000374226

Figure 7. Spacer - Rear Spring Hanger.

1. Spacer

29. Non double C-channel frame rail equipped vehicles, remove spacers (Figure 7, Item 1) between both spring hangers and frame rail lower flanges.

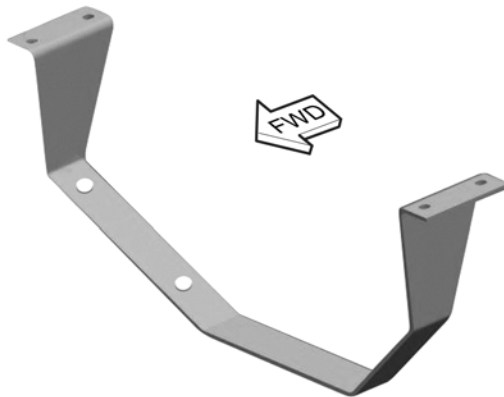

0000374233

Figure 8. Front Driveshaft Loop Bracket Assembly Positioning.

NOTE: When installing the front driveshaft loop bracket, the two large front driveshaft loop bolt holes must be oriented to the passenger side of the truck.

NOTE: If the vehicle being serviced is equipped with a double C-channel frame rail, Step 30 must be performed.

30. If vehicle is equipped with a double C-channel frame rail, rear front drive shaft loop bracket mounting holes one half inch larger in diameter. Otherwise, proceed to next step.

31. Position front driveshaft loop bracket in a manner that orients the two large front driveshaft loop bolt holes to passenger side of vehicle (Figure 8).

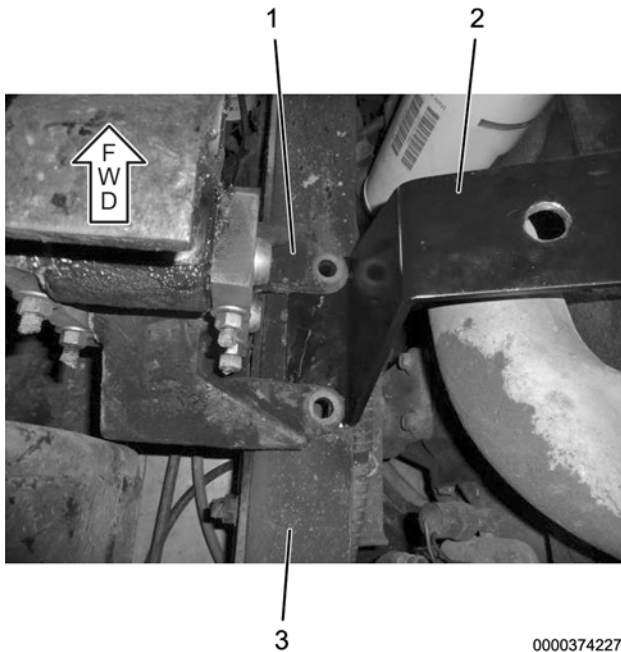

Figure 9. Front Driveshaft Loop Bracket.

1. Rear spring hanger
2. Driveshaft loop bracket
3. Frame rail

NOTE: If necessary, UNF 5/8 X 2 ½ inch bolts are not included in kit, and must be obtained locally.

32. Align driveshaft loop bracket (Figure 9, Item 2):

- a. Vehicles equipped with spacer(s) between hanger bracket and frame rail, align driveshaft loop bracket (Figure 9, Item 2) between rear spring hanger and frame rail (Figure 9, Items 1 & 3) in location of previously installed spacers on both sides of vehicle. Loosely install previously removed fasteners.
- b. Vehicles equipped with a double C-channel frame rail, align driveshaft loop bracket (Figure 9, Item 2) on top of the frame rail and install new UNF 5/8 X 2 ½ inch bolts.

33. Using torque wrench, tighten front axle spring hanger fasteners to 110 - 120 lb-ft (150 - 162 N·m).

NOTE: If the vehicle you are working on is equipped with a double C-channel frame rail, return to the appropriate driveshaft procedure:

- **If directed from step 9, proceed to Step 10.**
- **If directed from step 18, proceed to Step 19.**
- **Non double C-channel equipped vehicle, proceed to Step 34.**

34. Preassemble front driveshaft loop by threading a jamb nut halfway down on each side of loop. Place a washer over each jamb nut.

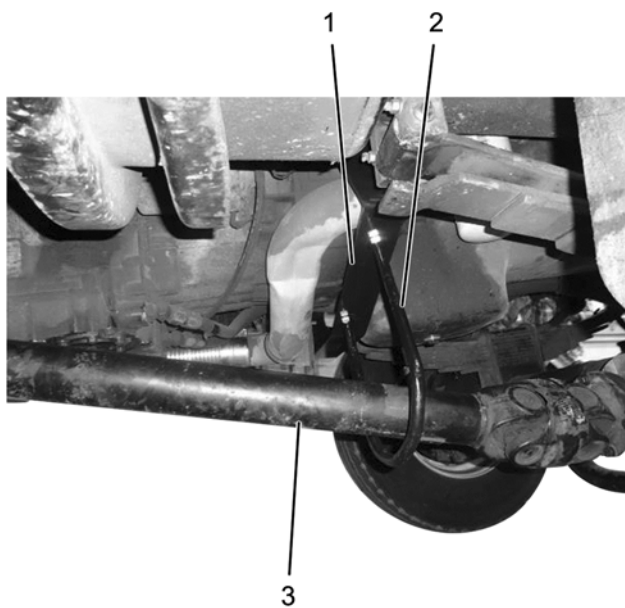
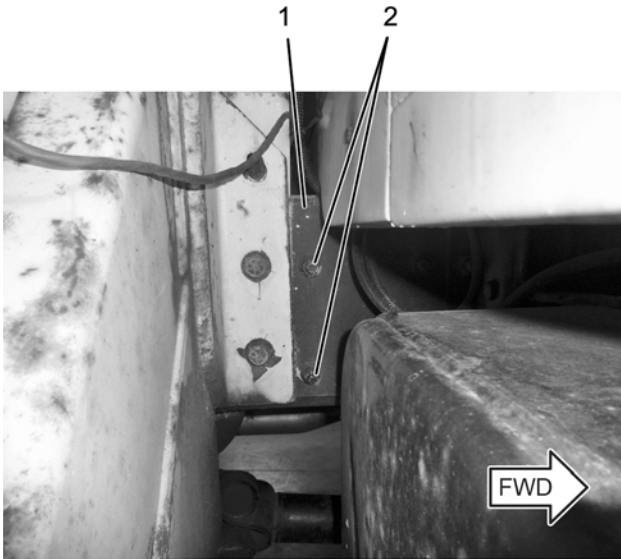

Figure 10. Front Driveshaft Loop.

1. Front driveshaft loop bracket
2. Driveshaft loop
3. Driveshaft

35. Install front driveshaft loop (Figure 10, Item 2) through holes in front loop bracket (Figure 10, Item 1). Loosely install one washer and then one jamb nut on each side of loop.

36. Adjust jamb nuts in a manner that driveshaft (Figure 10, Item 3) is centered in the loop with at least a 1 inch minimum clearance between driveshaft and loop. Once adjusted, tighten jamb nuts to 175 - 215 lb-ft (238 - 291 N·m).



0000374229

Figure 11. Cab Rear Crossmember Mounting Bolts.

1. Rear cab crossmember
2. Bolt (2)

37. Access cab rear crossmember (Figure 11, Item 1) on passenger side of vehicle.
38. Remove two rear mounting bolts (Figure 11, Item 2) that pass through frame rail. Save fasteners for reuse.

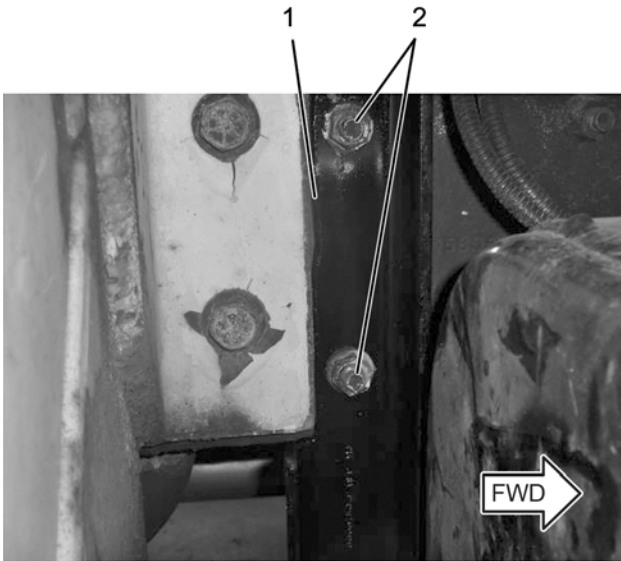

0000374230

Figure 12. Cab Rear Crossmember Mounting Bolts.

1. Rear driveshaft loop bracket
2. Mounting bolt (2)

39. Align and position rear driveshaft loop bracket (Figure 12, Item 1) flat against rear cab crossmember.
40. Install previously removed mounting bolts (Figure 12, Item 2). Using torque wrench, tighten fasteners to 110 - 120 lb-ft (150 - 162 N·m).
41. Preassemble rear driveshaft loop by threading a jamb nut halfway down on each side of loop. Place a washer over each jamb nut.

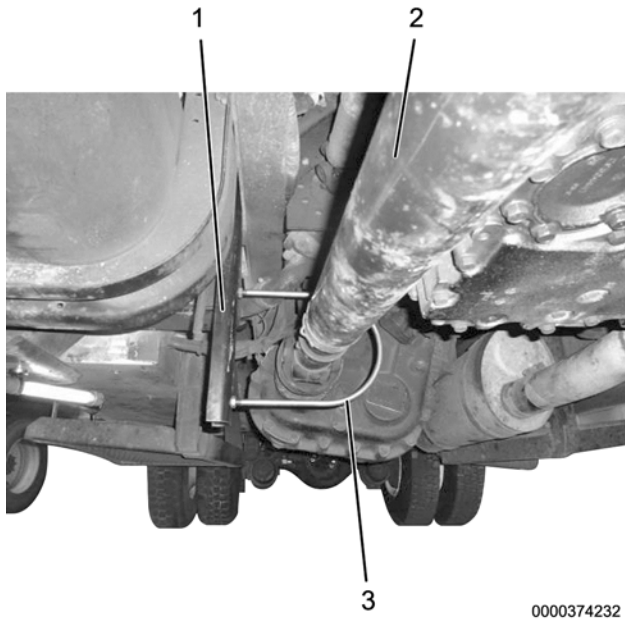

0000374232

Figure 13. Rear Driveshaft Loop Bracket.

1. Rear driveshaft loop bracket
2. Driveshaft
3. Rear driveshaft loop

NOTE: There are additional holes in the rear loop bracket to center the position of the rear loop in relation to the driveshaft.

42. Install rear driveshaft loop (Figure 13, Item 3) through holes in rear loop bracket (Figure 13, Item 1) that will center rear loop in relation to driveshaft. Loosely install one washer and then one jamb nut on each side of loop.
43. Adjust jamb nuts in a manner that driveshaft (Figure 13, Item 2) is centered in loop with at least a 1 inch minimum clearance between driveshaft and loop. Once adjusted, tighten jamb nuts to 175 - 215 lb-ft (238 - 291 N·m).

LOCKOUT HUB INSTALLATION

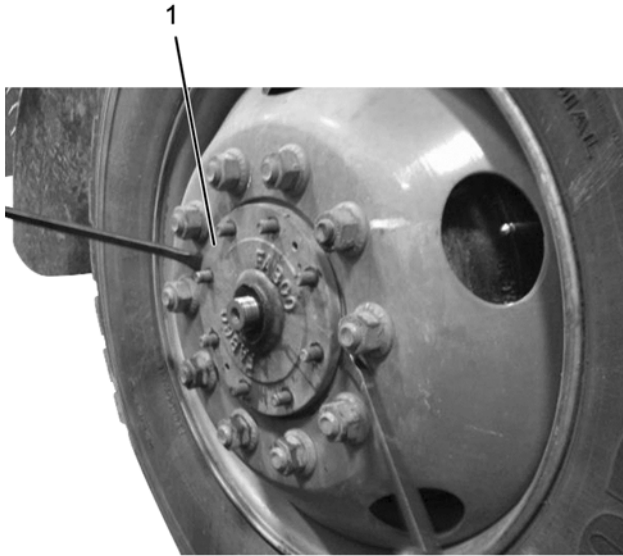

0000374283

Figure 14. Axle Drive Flange.

1. Axle drive flange

44. Using a 1 $\frac{3}{4}$ inch socket, remove center axle shaft nut from both front hubs and discard.
45. Remove eight nuts and washers securing axle drive flange (Figure 14, Item 1) to wheel hub. Discard nuts and washers, and repeat for opposite side.

NOTE: Axle drive flange should be able to be removed without excessive force.

46. Using a chisel or pry bar, gently loosen drive flange from wheel hub. Repeat for opposite side.
47. Using a clean, lint free cloth, remove any grease on the wheel hub.
48. Install kit-supplied lockout hubs; refer to Fabco instructions included with this letter.
49. Following installation, verify hub lock and freewheel functions are operating properly.
50. Remove jack stands and lower vehicle.
51. Remove wheel chocks.

NOTE: The following step is required for all vehicles converted to front lockout wheel hubs.

52. Upon completion of this recall, dealer must print lockout hub operator instructions included with this letter, train customer in usage of lockout hubs, and provide a copy to customer.

END OF SERVICE PROCEDURE

LABOR INFORMATION

Operation Number	Description	Time
A40-15506-1	Inspection ONLY	0.3 hr
A40-15506-2	Remove From Holding Fixture, Inspect Cardan Joints, and Install Previously Removed Driveshaft	1.0 hr
A40-15506-3	Inspect, Remove Front Driveshaft, Inspect Cardan Joints, and Reinstall Shaft	0.8 hr
A40-15506-4	Install Driveshaft Loops, Lockout Hubs Already Installed	2.0 hrs
A40-15506-5	Install Driveshaft Loops and Lock-Out Hubs	2.7 hrs
A40-15506-6	Ream Front Loop Bracket Mounting Holes, If Necessary	0.5 hr

ROAD CALL INFORMATION

When road call to customer location is necessary, enter the labor charges for travel time as “other charges” and attach technician time punches when submitting this campaign claim.

CAMPAIGN IDENTIFICATION LABEL

Each vehicle corrected in accordance with this campaign must be marked with a CTS-1075 Campaign Identification Label.

Complete the label and attach on a clean surface next to the vehicle identification number (VIN) plate.

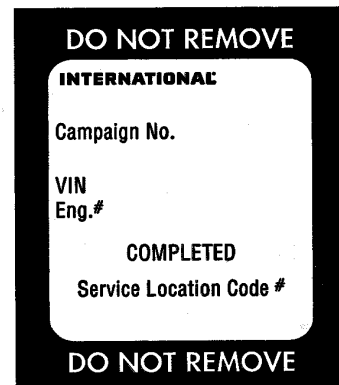

ADMINISTRATIVE / DEALER RESPONSIBILITIES

WARRANTY CLAIMS

Warranty claim expense is to be charged to Warranty. Claims are to be submitted in the normal manner, making reference to Safety Recall 15506.

It is important that the coding be completed properly to assist in processing the warranty claim. Complete instructions will be found in the Warranty Policy Manual, Section 7.1.8.

As with all claim submissions, items acquired locally must be submitted in the "Other Charges" tab. The cost of any bulk items (such as a bag of cable tie straps, roll of wire, a barrel of oil, or a tube of silicone) should be prorated for the cost of the individual pieces / amount used during each repair.

	GROUP	NOUN	C	WARR.	TP	PAD
GROUP — Enter number						
NOUN — Leave blank						
C (CAUSE) — Enter either 1, 2, 3. (See below)						
1. Inspected (No repair required).						
2. Inspected and repaired.						
3. Defective part from parts stock.						
WARRANTY — (Warranty Code) Enter 40.						
TYPE PART — Enter P for type part causing failure.						
PAD — Enter 100						

0000047910

UNITED STATES AND POSSESSIONS

The National Traffic and Motor Vehicle Safety Act, as amended, provides that each vehicle that is subject to a vehicle recall campaign must be adequately repaired within a reasonable time after the owner has tendered it for repair. A failure to adequately repair within 60 days after a tender of a vehicle is prima facie evidence of failure to repair within a reasonable time. If the condition is not adequately repaired within 60 days, the owner may be entitled to replacement with an identical or reasonable equivalent vehicle at no charge, or to a refund of the purchase price less a reasonable allowance for depreciation.

Dealers must correct all vehicles subject to this campaign at no charge to the owner, regardless of mileage, age of vehicle, or ownership, from this time forward.

VEHICLE RECALL 15506

Dealers should proceed immediately to make necessary correction to units in inventory. All inventory vehicles subject to this recall campaign must be corrected prior to sale, transfer or delivery. If vehicles have been sold or transferred and you are in receipt of Customer Notification Letters and Authorization for Recall Service cards for those vehicles, the transfer location or customer must be notified immediately from your dealer location.

Dealers must make every effort to promptly schedule an appointment with each owner to repair his or her vehicle as soon as possible. However, consistent with the customer notification, dealers are expected to complete the repairs on the mutually agreed upon service date.

Dealers involved in the recall process will be furnished a listing of owner names and addresses to enable them to follow up with owners and have the vehicles corrected. Use of this listing must be limited to this campaign because the list may contain information obtained from state motor vehicle registration records, and the use of such motor vehicle registration data for purposes other than this campaign is a violation of law in several states.

CANADA

Dealers must correct all vehicles subject to this campaign at no charge to the owner, regardless of mileage, age of vehicle, or ownership, from this time forward.

Dealers should proceed immediately to make necessary correction to units in inventory. All inventory vehicles subject to this recall campaign must be corrected prior to sale, transfer or delivery. If vehicles have been sold or transferred and you are in receipt of Customer Notification Letters and Authorization for Recall Service cards for those vehicles, the transfer location or customer must be notified immediately from your dealer location.

Dealers must make every effort to promptly schedule an appointment with each owner to repair his or her vehicle as soon as possible. However, consistent with the customer notification, dealers are expected to complete the repairs on the mutually agreed upon service date.

Dealers involved in the recall process will be furnished a listing of owner names and addresses to enable them to follow up with owners and have the vehicles corrected. Use of this listing must be limited to this campaign because the list may contain information obtained from state motor vehicle registration records, and the use of such motor vehicle registration data for purposes other than this campaign is a violation of law in several states.

EXPORT

Export Distributors should proceed immediately to make necessary correction to units in inventory. All inventory vehicles subject to this recall campaign must be corrected prior to sale, transfer or delivery. If vehicles have been sold or transferred and you are in receipt of Customer Notification Letters and Authorization for Recall Service cards for those vehicles, the transfer location or customer must be notified immediately from your distributor location.

Export Distributors are to submit warranty claims in the usual manner making reference to this recall number.

Export Distributors are expected to provide full cooperation and follow-up with respect to this important subject matter. If you have any questions or need further assistance, please contact the Regional Service Manager at your regional office.

NAVISTAR, INC.